

M9CV/M9/M9T
Diagnostic Ultrasound System

Operator's Manual

[Basic Volume]

Contents

Contents	i
Intellectual Property Statement	I
Responsibility on the Manufacturer Party	I
Warranty	II
Exemptions	II
Customer Service Department	III
Important Information	IV
About This Manual	IV
Notation Conventions	IV
Operator's Manuals	V
Hardcopy Manuals	V
Software Interfaces in this Manual	V
Conventions	VI
Product Difference	VI
1 Safety Precautions	1-1
1.1 Safety Classifications	1-1
1.2 Meanings of Signal Words	1-2
1.3 Meaning of Safety Symbols	1-2
1.4 Safety Precautions	1-3
1.5 Latex Alert	1-9
1.6 Warning Labels	1-10
2 System Overview	2-1
2.1 Intended Use	2-1
2.2 Contraindication	2-1
2.3 Product and Model Code	2-1
2.4 Product Specifications	2-2
2.5 System Configuration	2-3
2.6 Introduction of Each Unit	2-7
2.7 Extend Module	2-9
2.8 Control Panel	2-11
2.9 Symbols	2-16
3 System Preparation	3-1
3.1 Move/Position the System	3-1
3.2 Power ON/OFF	3-2
3.3 Connecting the Power Cord	3-4
3.4 Connecting a Probe	3-5
3.5 Connecting the Footswitch	3-6
3.6 Connecting USB Devices	3-6
3.7 Installing a Printer	3-7
3.8 Basic Screen & Operation	3-10
4 Exam Preparation	4-1
4.1 Patient Information	4-1
4.2 Select Exam Mode and Probe	4-9
4.3 Select the Imaging Mode	4-9
4.4 Pause & End an Exam	4-10
4.5 Activate & Continue an Exam	4-10

5	Image Optimization	5-1
5.1	Imaging Mode.....	5-1
5.2	B Mode Image Optimization	5-4
5.3	M Mode Image Optimization	5-11
5.4	Color Mode Image Optimization.....	5-14
5.5	Power Mode Image Optimization	5-19
5.6	PW/CW Doppler Mode	5-21
5.7	Color M Mode	5-28
5.8	Anatomical M Mode.....	5-29
5.9	TDI.....	5-32
5.10	iScape View (Real-time Panoramic Imaging).....	5-37
5.11	Left Ventricular Opacification (LVO)	5-41
5.12	Elastography.....	5-45
5.13	Stress Echo	5-47
5.14	Tissue Tracking Quantitative Analysis (QA)	5-58
6	Display & Cine Review.....	6-1
6.1	Splitting Display	6-1
6.2	Image Magnification	6-1
6.3	Freeze/Unfreeze the Image.....	6-2
6.4	Cine Review	6-3
6.5	Image Compare.....	6-5
6.6	Cine Saving	6-6
6.7	Preset	6-8
7	Physiological Signal	7-1
7.1	ECG.....	7-2
7.2	Respiratory Wave	7-3
7.3	Parameter Description.....	7-4
8	Measurement.....	8-1
8.1	Basic Operations	8-1
8.2	General Measurements	8-2
8.3	Application Measurements	8-3
8.4	Measurement Accuracy.....	8-4
9	Comments and Body Marks	9-1
9.1	Comments	9-1
9.2	Body Mark	9-6
10	Patient Data Management	10-1
10.1	Patient Information Management	10-1
10.2	Image File Management.....	10-1
10.3	Report Management.....	10-9
10.4	iStation - Patient Data Management.....	10-11
10.5	iStorage	10-15
10.6	Print	10-15
10.7	Back Up Files using the DVD Drive.....	10-16
10.8	Patient Task Management.....	10-17
10.9	Administration	10-18
10.10	V-Access.....	10-20
11	DICOM/HL7	11-1
11.1	DICOM Preset	11-2

11.2	Verify Connectivity.....	11-8
11.3	DICOM Services.....	11-9
11.4	DICOM Media Storage.....	11-13
11.5	Structured Report.....	11-15
11.6	DICOM Task Management.....	11-15
12	Setup.....	12-1
12.1	System Preset.....	12-2
12.2	Exam Preset.....	12-8
12.3	Measurement Preset.....	12-8
12.4	Comment Preset.....	12-9
12.5	iWorks Preset.....	12-10
12.6	Stress Echo Preset.....	12-10
12.7	DICOM Preset.....	12-10
12.8	Network Preset.....	12-10
12.9	Print Preset.....	12-11
12.10	Maintenance.....	12-12
12.11	System Information.....	12-13
13	Probes and Biopsy.....	13-1
13.1	Probes.....	13-1
13.2	Biopsy Guide.....	13-13
13.3	Middle Line.....	13-32
14	DVR Recording.....	14-1
15	Acoustic Output.....	15-1
15.1	Concerns with Bioeffects.....	15-1
15.2	Prudent Use Statement.....	15-1
15.3	ALARA Principle (As Low As Reasonably Achievable).....	15-1
15.4	MI/TI Explanation.....	15-2
15.5	Acoustic Power Setting.....	15-3
15.6	Acoustic Power Control.....	15-4
15.7	Acoustic Output.....	15-4
15.8	Measurement Uncertainty.....	15-5
15.9	References for Acoustic Power and Safety.....	15-6
16	Guidance and Manufacturer's Declaration.....	16-1
17	System Maintenance.....	17-1
17.1	Daily Maintenance.....	17-1
17.2	Troubleshooting.....	17-6
Appendix A	Wireless LAN.....	A-1
Appendix B	Battery.....	B-1
Appendix C	iWorks (Auto Workflow Protocol).....	C-1
Appendix D	Barcode Reader.....	D-1
Appendix E	Trolley.....	E-1
Appendix F	Electrical Safety Inspection.....	F-1

© 2013-2014 Shenzhen Mindray Bio-Medical Electronics Co., Ltd. All rights Reserved.

For this Operator's Manual, the issue date is 2015-02.

This version of the manual applies to 01.00.00 software for the M9CV/M9T/M9 ultrasound system.

Intellectual Property Statement

SHENZHEN MINDRAY BIO-MEDICAL ELECTRONICS CO., LTD. (hereinafter called Mindray) owns the intellectual property rights to this Mindray product and this manual. This manual may refer to information protected by copyright or patents and does not convey any license under the patent rights or copyright of Mindray, or of others.

Mindray intends to maintain the contents of this manual as confidential information. Disclosure of the information in this manual in any manner whatsoever without the written permission of Mindray is strictly forbidden.

Release, amendment, reproduction, distribution, rental, adaptation, translation or any other derivative work of this manual in any manner whatsoever without the written permission of Mindray is strictly forbidden.

 ,  ,  ,  ,  ,  BeneView, WATO, BeneHeart,

 are the trademarks, registered or otherwise, of Mindray in China and other countries. All other trademarks that appear in this manual are used only for informational or editorial purposes. They are the property of their respective owners.

Responsibility on the Manufacturer Party

Contents of this manual are subject to change without prior notice.

All information contained in this manual is believed to be correct. Mindray shall not be liable for errors contained herein or for incidental or consequential damages in connection with the furnishing, performance, or use of this manual.

Mindray is responsible for the effects on safety, reliability and performance of this product, only if:

- all installation operations, expansions, changes, modifications and repairs of this product are conducted by Mindray authorized personnel;
- the electrical installation of the relevant room complies with the applicable national and local requirements; and
- the product is used in accordance with the instructions for use.

 Note 

This equipment must be operated by skilled/trained clinical professionals.

 Warning 

It is important for the hospital or organization that employs this equipment to carry out a reasonable service/maintenance plan. Neglect of this may result in machine breakdown or personal injury.

Warranty

THIS WARRANTY IS EXCLUSIVE AND IS IN LIEU OF ALL OTHER WARRANTIES, EXPRESSED OR IMPLIED, INCLUDING WARRANTIES OF MERCHANTABILITY OR FITNESS FOR ANY PARTICULAR PURPOSE.

Exemptions

Mindray's obligation or liability under this warranty does not include any transportation or other charges or liability for direct, indirect or consequential damages or delay resulting from the improper use or application of the product or the use of parts or accessories not approved by Mindray or repairs by people other than Mindray authorized personnel.

This warranty shall not extend to:

- **Malfunction or damage caused by improper use or man-made failure.**
- **Malfunction or damage caused by unstable or out-of-range power input.**
- **Malfunction or damage caused by force majeure such as fire and earthquake.**
- **Malfunction or damage caused by improper operation or repair by unqualified or unauthorized service people.**
- **Malfunction of the instrument or part whose serial number is not legible enough.**
- **Others not caused by instrument or part itself.**

Customer Service Department

Manufacturer: Shenzhen Mindray Bio-Medical Electronics Co., Ltd.
Address: Mindray Building, Keji 12th Road South, High-tech industrial park,
Nanshan, Shenzhen 518057, P.R.China
Website: www.mindray.com
E-mail Address: service@mindray.com
Tel: +86 755 81888998
Fax: +86 755 26582680

Manufacturer: Mindray DS USA, Inc.
Address: 800 MacArthur Blvd.
Mahwah, NJ 07430-0619 USA
Tel: +1(201) 995-8000
Toll Free: +1 (800) 288-2121
Fax: +1 (800) 926-4275

Important Information

1. It is the customer's responsibility to maintain and manage the system after delivery.
2. The warranty does not cover the following items, even during the warranty period:
 - (1) Damage or loss due to misuse or abuse.
 - (2) Damage or loss caused by Acts of God such as fires, earthquakes, floods, lightning, etc.
 - (3) Damage or loss caused by failure to meet the specified conditions for this system, such as inadequate power supply, improper installation or environmental conditions.
 - (4) Damage or loss due to use of the system outside the region where the system was originally sold.
 - (5) Damage or loss involving the system purchased from a source other than Mindray or its authorized agents.
3. This system shall not be used by persons other than fully qualified and certified medical personnel.
4. DO NOT make changes or modifications to the software or hardware of this system.
5. In no event shall Mindray be liable for problems, damage, or loss caused by relocation, modification, or repair performed by personnel other than those designated by Mindray.
6. The purpose of this system is to provide physicians with data for clinical diagnosis. The physician is responsible for the results of diagnostic procedures. Mindray shall not be liable for the results of diagnostic procedures.
7. Important data must be backed up on external memory media.
8. Mindray shall not be liable for loss of data stored in the memory of this system caused by operator error or accidents.
9. This manual contains warnings regarding foreseeable potential dangers, but you shall also be continuously alert to dangers other than those indicated. Mindray shall not be liable for damage or loss resulting from negligence or ignorance of the precautions and operating instructions described in this operator's manual.
10. If a new manager takes over this system, be sure to hand over this operator's manual to the new manager.

About This Manual

This operator's manual describes the operating procedures for this diagnostic ultrasound system and the compatible probes. To ensure safe and correct operation, carefully read and understand the manual before operating the system.

Notation Conventions

In this operator's manual, the following words are used besides the safety precautions (see "Safety Precautions"). Please read this operator's manual before using the system.

NOTE: Indicates information of interest to users of this system regarding exceptional conditions or operating procedures.
--

⚠ CAUTION: The diagnostic ultrasound system is not intended for ophthalmic use. Its use in this clinical specialty is contraindicated.

U.S.A. Federal Law restricts this device to sale by or on the order of a physician.

Operator's Manuals

You may receive multi-language manuals on compact disc or paper. Please refer to the English manual for the latest information and registration information.

The content of the operator manual, such as screens, menus or descriptions, may be different from what you see in your system. The content varies depending on the software version, options and configuration of the system.

Hardcopy Manuals

- Operator's Manual [Basic Volume]
Describes the basic functions and operations of the system, safety precautions, exam modes, imaging modes, preset, maintenance and acoustic output, etc.
- Operator's Manual [Advanced Volume]
- Operator's Manual [Acoustic Power Data and Surface Temperature Data]
Contains data tables of acoustic output for transducers.
- Operation Note
Contains a quick guide for basic system operations.

NOTE: Manuals on CD are the manuals translated into languages other than English, according to the English manuals.

If you find that the contents of the manuals on CD are NOT consistent with the system or the English manuals, refer ONLY to the corresponding English manuals.

The accompanying manuals may vary depending on the specific system you purchased. Please refer to the packing list.

Software Interfaces in this Manual

Depending on the software version, preset settings and optional configuration, the actual interfaces may be different from those in this manual.

Conventions

In this manual, the following conventions are used to describe the buttons on the control panel, items in the menus, buttons in the dialog boxes and some basic operations:

- <Buttons>: angular brackets indicate buttons, knobs and other controls on the control panel or on the keyboard.
- [Items in menu or buttons in dialog box]: square brackets indicate items in menus, on the soft menu or buttons in dialog boxes.
- Click [Items or Buttons]: move the cursor to the item or button and press <Set> or use the soft key corresponding to the soft menu.
- [Items in menu] → [Items in submenu]: select a submenu item following the path.

Product Difference



Product Model	B-Histogram	B-Profile
M9	√	√
M9CV	×	√
M9T	√	×



1 Safety Precautions

1.1 Safety Classifications





- According to the type of protection against electric shock:
Class I equipment
- According to the degree of protection against electric shock:
Type-BF applied part
- According to the degree of protection against harmful ingress of water:
The main unit is rated IPX0
The probes are rated IPX7, the power adapter is rated IPX1
The foot switch (can be applied in the operating room): 1-pedal type is rated IPX8, 2-pedal and 3-pedal types are rated IP68.
- According to the disinfection and sterilization method(s) recommended by manufacturer:
Equipment with disinfection and sterilization method(s) recommended by manufacturer.
- According to the degree of safety of application in the presence of a FLAMMABLE ANESTHETIC MIXTURE WITH AIR or WITH OXYGEN OR NITROUS OXIDE
EQUIPMENT not suitable for use in the presence of a FLAMMABLE ANESTHETIC MIXTURE WITH AIR or WITH OXYGEN OR NITROUS OXIDE
- According to the mode of operation:
Continuous operation
- According to the installation and use:
Portable equipment
Mobile equipment (when the system is installed on the mobile trolley)
- Does the equipment has any defibrillation-proof applied parts:
Non-defibrillation-proof applied part
- Permanently installed equipment or non-permanently installed equipment:
Non-permanently installed equipment

1.2 Meanings of Signal Words

In this manual, the signal words  **DANGER**,  **WARNING**,  **CAUTION**, **NOTE** and **Tip** are used regarding safety and other important instructions. The signal words and their meanings are defined as follows. Please understand their meanings clearly before reading this manual.

Signal word	Meaning
 DANGER	Indicates an imminently hazardous situation that, if not avoided, will result in death or serious injury.
 WARNING	Indicates a potentially hazardous situation that, if not avoided, could result in death or serious injury.
 CAUTION	Indicates a potentially hazardous situation that, if not avoided, may result in minor or moderate injury.
NOTE	Indicates a potentially hazardous situation that, if not avoided, may result in property damage.
Description	Important information that helps you use the system more effectively.

1.3 Meaning of Safety Symbols

Symbol	Description
	Type-BF applied part The ultrasound probes connected to this system are type-BF applied parts. The ECG leads within this system is type-BF applied part.
	Caution.
	General warning sign.
	Patient/user infection due to contaminated equipment. Be careful when performing cleaning, disinfection and sterilization.
	Patient injury or tissue damage from ultrasonic radiation. The ALARA principle must be practiced when operating the ultrasound system.

1.4 Safety Precautions

Please observe the following precautions to ensure patient and operator's safety when using this system.



DANGER:

DO NOT use flammable gasses, such as anesthetic gas or hydrogen, or flammable liquids such as ethanol, near this system, because there is danger of explosion.



WARNING:

1. Do not connect the adapter power plug of this system and power plugs of the peripherals to wall receptacles that meet the ratings indicated on the rating nameplate. Using a multifunctional receptacle may affect the system protective grounding performance, and cause the leakage current to exceed safety requirements.
Use the cable provided with this system to connect the printer. Other cables may result in electric shock.
You must use the power adapter provided with the system; otherwise electric shock may result.
You can only adopt the power supply method provided by Mindray, other power supply modes (e.g. using a UPS) may result in electric shock.
2. Connect the protective grounding conductor before turning ON the system. Disconnect the grounding cable after turning OFF the system. Otherwise, electric shock may result.
3. For the connection of power and grounding, follow the appropriate procedures described in this operator's manual. Otherwise, there is risk of electric shock. DO NOT connect the grounding cable to a gas pipe or water pipe; otherwise, improper protective grounding may result or a gas explosion may occur.
4. Before cleaning the system, disconnect the power cord from the outlet. System failure and electric shock may result.
5. This system is not water-proof designed. DO NOT use this system in any place where water or any liquid leakage may occur. If any water is sprayed on or into the system, electric shock or device malfunction may result. If water is accidentally sprayed on or into the system, power off the system immediately and contact Mindray Customer Service Department or sales representative.
6. DO NOT use a probe that has a damaged, scratched surface, or exposed wiring of any kind. Immediately stop using the probe and contact Mindray Customer Service Department or sales representative. There is risk of electric shock if a damaged or scratched probe is used.
7. DO NOT allow the patient to contact the live parts of the ultrasound system or other devices, e.g. signal I/O ports. Electric shock may occur.

8. Do not use an aftermarket probe other than those specified by Mindray. The probes may damage the system, causing a profound failure, e.g. a fire in the worst case.
9. Do not subject the probes to knocks or drops. Use of a defective probe may cause an electric shock.
10. Do not open the covers and front panel of the system. Short circuit or electric shock may result when the system hardware is exposed and powered on.
11. DO NOT use this system simultaneously with equipment such as an electrosurgical unit, high-frequency therapy equipment, or a defibrillator, etc. Otherwise, there is a risk of electric shock to the patient.
12. Only use the ECG leads provided with the ECG module; otherwise electric shock may result.
13. When moving the system, you should first fold the LCD display, disconnect the system from other devices (including probes) and disconnect the system from the power supply.
14. Accessory equipment connected to the analog and digital interfaces must comply with the relevant IEC standards (e.g., IEC 60950 information technology equipment safety standard and IEC 60601-1 medical equipment standard). Furthermore, all configurations must comply with the standard IEC 60601-1 chapter 16 ME System. It is the responsibility of the person, who connects additional equipment to the signal input or output ports and configures a medical system, to verify that the system complies with the requirements of IEC 60601-1 chapter 16 ME System. If you have any questions regarding these requirements, consult your sales representative.
15. Prolonged and repeated use of keyboards may result in hand or arm nerve disorders for some individuals. Observe the local safety or health regulations concerning the use of keyboards.
16. DO NOT contact both the patient and the ultrasound system or the live parts of the ultrasound system (e.g. signal I/O ports). Electric shock may occur.
17. When using intra-cavity transducers, do not activate the transducer outside the patient's body.
18. If you have any doubts of the installation or routing of external protective cables, use the internal power supply of the system.
19. DO NOT put the ultrasound system in any soft materials (e.g. soft cloth or cotton, etc.) in case that the cooling vent may be blocked.
20. Always read and follow carefully the manufacturer instructions on the contrast agent label.

 **CAUTION:**

1. **Precautions concerning clinical examination techniques:**
This system must be used only by qualified medical professionals.
This operator's manual does not describe clinical examination techniques. The clinician should select the proper examination techniques based on specialized training and clinical experience.
2. **Malfunctions due to radio wave:**
 - If a radio wave emitting device is used in the proximity of this system, it may interfere with operations. **DO NOT** use or take any devices transmitting RF signals (such as cellular phones, transceivers and radio controlled products) in the room placing the system.
 - If a person brings a device that generates radio waves near the system, ask him / her to immediately turn OFF the device.
3. **Precautions concerning movement of the system:**
 - When you place the system on the mobile trolley and move them together, you must secure all objects on the mobile trolley to prevent them from falling. Otherwise you should separate the system from the mobile trolley and move them individually.
When you have to move the system with the mobile trolley upward or downward the stairs, you must separate them first and then move them individually.
 - Object placed on the monitor may fall and injure an individual when moving.
 - Confirm that there is no peripheral device connected to the system before moving the system. Otherwise, peripheral device may fall and injure an individual.
4. **DO NOT expose the system to excessive vibration through transportation. Mechanical damage may result.**
5. **Do not connect this system to outlets with the same circuit breakers and fuses that control the current of devices such as life-support systems. If this system malfunctions and generates over current, or when there is an instantaneous current at power ON, the circuit breakers and fuses of the building's supply circuit may be tripped.**
6. **Always keep the system dry. Avoid transporting this system quickly from a cold place to a warm place; otherwise condensation or water droplets may form allowing a short circuit and possible electric shock.**
7. **If the circuit protector is tripped, it indicates that the system or a peripheral device was improperly shut down and the system is unstable. You cannot repair the system under this circumstance and must call the Mindray Customer Service Department or sales representative.**

8. There is no risk of high-temperature burns during normal ultrasound examinations. It is possible for the surface temperature of the probe to exceed the body temperature of a patient due to environmental temperature and exam mode combinations. Apply the probe only for a period of time required for the purpose of diagnosis.
9. The system and its accessories are not disinfected or sterilized prior to delivery. The operator is responsible for the cleaning and disinfection of probes and sterilization of biopsy brackets according to the manuals, prior to the use.
All items must be thoroughly processed to completely remove harmful residual chemicals, which will not only harmful to the human body, but also damage the accessory.
10. It is necessary to press <End Exam> to end the current scan that is in progress and clear the current Patient Information field. Otherwise, new patient data may be combined with the previous patient data.
11. **DO NOT** connect or disconnect the system's power cord or its accessories (e.g., a printer or a recorder) without turning **OFF** the power first. This may damage the system and its accessories or cause electric shock.
12. If the system is powered off improperly during operation, it may result in data damage of the system's hard disk or system failure.
13. Do not use the system to examine a fetus for a long period of time.
14. Do not use a USB memory device (e.g., a USB flash drive, removable hard disk) which has unsafe data. Otherwise, system damage may result.
15. It is recommended to only use the video devices specified in this manual.
16. Do not use gel, disinfectant, probes, probe sheath or needle-guided brackets that are not compatible with the system.
17. Read the Acoustic Output Principle in the operation manual carefully before operate this system on clinical examination.
18. Please use the ultrasound gel compliant with the relevant local regulations.

- NOTE:
1. DO NOT use the system in the vicinity of strong electromagnetic field (such as a transformer), which may affect the performance of the system.
 2. DO NOT use the system in the vicinity of high-frequency radiation source, which may affect the performance of the system or even lead to failure.

3. To avoid damaging the system, DO NOT use it in following environment:
 - (1) Locations exposed to direct sunlight.
 - (2) Locations subject to sudden changes in environmental temperature.
 - (3) Dusty locations.
 - (4) Locations subject to vibration.
 - (5) Locations near heat generators.
 - (6) Locations with high humidity.
4. Turn ON the system only after the power has been turned OFF for a while. If the system is turned ON immediately after being turned OFF, the system may not be rebooted properly and could malfunction.
5. When using or placing the system, keep the system horizontal to avoid imbalance.
6. Remove ultrasound gel from the face of a probe when the examination is complete. Water in the gel may enter the acoustic lens and adversely affect the performance and safety of the probe.
7. You should properly back up the system to a secure external storage media, including system configuration, settings and patient data. Data stored to the system's hard drive may be lost due to system failure, improper operation or accident.
8. Do not apply external force to the control panel; otherwise, the system may be damaged.
9. If the system is used in a small room, the room temperature may rise. Please provide proper ventilation and free air exchange.
10. To dispose of the system or any part, contact Mindray Customer Service Department or sales representative. Mindray is not responsible for any system content or accessories that have been discarded improperly.
11. Electrical and mechanical performance may be degraded due to long usage (such as current leakage or distortion and abrasion); the image sensitivity and precision may become worse too. To ensure optimal system operations, it is recommended that you maintain the system under a Mindray service agreement.
12. The iScape feature constructs a single extended image from a series of individual image frames. The quality of the final image is user-dependent and requires skill to efficiently apply the feature and technique. Exercise caution when measurements are performed from an iScape image.
13. Ensure that the current exam date and time are the same as the system date and time.
14. DO NOT turn OFF the power supply of the system during printing, file storage or invoking other system operations. An interrupted process may not be completed, and can become lost or corrupted.
15. Use detachable power supply cord as mains power breaking device. DO NOT set equipment in place where difficult for disconnection of detachable power supply cord!

Please read the following precautions carefully to ensure the safety of the patient and the operator when using the probes.



WARNING:

1. **The ultrasonic probe is only for use with the specified ultrasonic diagnostic system. Please refer to the 2.5.2 Probes and Needle-guided Brackets Available to select the proper probe.**

2. Confirm that the probe and cable are normal before and after each examination. A defective probe may cause electric shock to the patient.
3. Do not subject the probe to shock. A defective probe may cause electric shock to the patient.
4. Do not disassemble the probe to avoid the possibility of electric shock.
5. Never immerse the probe connector into liquids such as water or disinfectant because the connector is not waterproof. Immersion may cause electric shock or malfunction.
6. A probe sheath must be installed over the probe before performing intra-cavity or intra-operative examination.

**CAUTION:**

1. When using the probe, wear sterile gloves to prevent infection.
2. Be sure to use sterile ultrasound gel. Please use the ultrasound gel compliant with the relevant local regulations. And manage the ultrasound gel properly to ensure that it does not become a source of infection.
3. In normal diagnostic ultrasound mode, there is no danger of a normal-temperature burn; however, keeping the probe on the same region of the patient for a long time may cause such a burn.
4. Do not use the carrying case for storing the probe. If the carrying case is used for storage, it may become a source of infection.
5. It is required to practice ALARA when operating ultrasound system. Minimize the acoustic power without compromising the quality of images.
6. The probe and accessories supplied with it are not delivered disinfected or sterilized. Sterilization (or high-level disinfect) before use is required.
7. Disposable components (for example the probe sheath, the sterile gloves) are packaged sterile and are single-use only. Do not use if integrity of packaging violated or if expiration date has passed. Please use the disposable components compliant with the relevant local regulations.
8. Please use the disinfection or sterilization solution that recommended in this operator's manual; otherwise Mindray will not be liable for damage caused by other solutions. If you have any questions, please contact Mindray Customer Service Department or sales representative.
9. The probe sheath contains natural rubber that can cause allergic reactions in some individuals.
10. Do not use pre-lubricated condoms as a sheath. Lubricant may not be compatible with the transducer material and damage may result.

Transducer damage may be caused by inappropriate gel, detergent or cleanser:

11. **Do not soak or saturate transducers with solutions containing alcohol, bleach, ammonium chloride compounds, acetone or formaldehyde.**

Avoid contact with solutions or coupling gels containing mineral oil or lanolin.

12. **The contrast agent used must comply with the relevant local regulations.**

NOTE: 1. Read the following precautions to prevent the probe from malfunction:

- Clean and disinfect the probe before and after each examination.
- After the examination, wipe off the ultrasound gel thoroughly. Otherwise, the ultrasound gel may solidify and the image quality would be degraded.

2. Ambient conditions:

To prevent the probe from being damaged, do not use it where it will be exposed to:

- Direct sunlight or X-rays
- Sudden changes in temperature
- Dust
- Excessive vibration
- Heat generators

Use the probes under the following ambient conditions:

- ambient temperature: 0°C ~ 40°C
- relative humidity: 30% ~ 85% (no condensation)
- atmospheric pressure: 700 hPa ~ 1060 hPa.

3. Repeated disinfection will eventually damage the probe, please check the probe's performance periodically.

1.5 Latex Alert

When choosing a probe sheath, it is recommended that you directly contact CIVCO for obtaining information regarding probe sheaths, pricing, samples and local distribution. For CIVCO information, please contact the following:

CIVCO Medical Instruments

Tel: 1-800-445-6741

www.civco.com



WARNING:





Allergic reactions in patients sensitive to latex (natural rubber) may range from mild skin reactions (irritation) to fatal anaphylactic shock, and may include difficulty breathing (wheezing), dizziness, shock, swelling of the face, hives, sneezing, or itching of the eyes (FDA Medical Alert on latex products, "Allergic Reactions to Latex-containing Medical Devices", issued on March 29, 1991).

1.6 Warning Labels

Warning labels are attached to this system to call your attention to potential hazards. The symbol  on warning labels indicates safety precautions.

The warning labels use the same signal words as those used in the operator’s manual. Read the operator’s manual carefully before using the system.

The name, design and meaning of each warning label are described as follows:

No.	Warning Labels	Meaning
1.		Read this information carefully before using the system.
2.		There is explosion risk if the system is used in flammable anesthetics.
3.	<p>The following labels are available when the system works with the mobile trolley.</p>  <p>a</p> <p>b</p> <p>c</p>	<p>(a) Do not place the system with the mobile trolley on a sloped surface. Otherwise the system may slide, resulting in personal injury or the system malfunction. Two persons are required to move the system over a sloped surface.</p> <p>b DO NOT sit on the trolley.</p> <p>c When the casters are locked, DO NOT push the trolley.</p>
4.	<p>ETL CLASSIFIED</p>  <p>Intertek</p> <p>3191955</p>	<p>CONFORMS TO AAMI STD 60601-1, IEC STD 60601-2-37, IEC STD 60601-2-18;</p> <p>CERTIFIED TO CSA STD C22.2 NO. 60601-1, 60601-2-37, 60601-2-18</p>

2 System Overview

2.1 Intended Use

The M9/M9CV/M9T Diagnostic Ultrasound System is applicable for adults, pregnant women, pediatric patients and neonates. It is intended for use in fetal, abdominal, pediatric, small organ(breast, thyroid, testes), neonatal and adult cephalic, trans-rectal, trans-vaginal, musculo-skeletal(conventional, superficial), adult and pediatric cardiac, trans-esoph.(Cardiac), peripheral vessel , urology exams.

2.2 Contraindication

This ultrasound system should not be used in ophthalmic procedures or any procedure that causes the acoustic beam to pass through the eye.

2.3 Product and Model Code



NOTE: The functions described in the operator's manual may vary depending on the specific system purchased.

2.4 Product Specifications

2.4.1 Imaging Mode

B Mode	B
M Mode	M
C Mode	Color Power(DirPower)
D Mode	PW/CW
Special imaging	Color M Anatomical M: Free Xros M, Free Xros CM iScape View(panoramic imaging) Elastography LVO Stress Echo TDI (Tissue Doppler imaging) Tissue Tracking QA

2.4.2 Power supply

Voltage	100-240 V~
Frequency	50/60Hz
Power input	2.0A max
Fuse	250V~T5AL

2.4.3 Environmental Conditions

	Operating conditions	Storage and transportation conditions
Ambient temperature	0°C~40°C	-20°C~55°C
Relative humidity	30%~85% (no condensation)	20%~95% (no condensation)
Atmospheric pressure	700hPa~1060hPa	700hPa~1060hPa

 **WARNING:** Do not use this system in conditions other than those specified.

2.4.4 Dimensions and Weight

Dimensions: $(362 \pm 5) \times (390 \pm 5) \times (59 \pm 3)$ mm

Weight (including batteries): <6.5KG.

2.5 System Configuration

2.5.1 Standard Configuration

- Main unit
- Keyboard
- Power adapter
- Built-in batteries
- WIFI
- System software
- Travelling case
- Accessories
 - Operator's manual and operation note
 - Ultrasound gel (made by Eco-Med Pharmaceuticals, model: Eco Gel 200, K955246)
 - Cables
 - Multilingual controls overlay
 - User-defined label

Applied part: probe and ECG.

2.5.2 Probes and Needle-guided Brackets Available

Probe model	Probe Type	Intended Use	Region Applied
C5-1s	Convex	Fetal, abdominal, pediatric, musculo-skeletal (Conventional), peripheral vessel	Body surface
L12-4s	Linear	Abdominal, pediatric, small organ (breast, thyroid, testes), neonatal cephalic, musculo-skeletal (conventional, superficial), peripheral vessel	Body surface
P10-4s	Phased	Abdominal, pediatric, neonatal cephalic, cardiac pediatric	Body surface
P7-3Ts	Phased	Trans-esoph. (cardiac)	Transesophageal
L14-6Ns	Linear	Abdominal, pediatric, small organ (breast, thyroid, testes), neonatal cephalic, musculo-skeletal (conventional, superficial), peripheral vessel	Body surface
V11-3Ws	Convex	Fetal, trans-rectal, trans-vaginal, urology	Transvaginal
C11-3s	Convex	Abdominal, pediatric, neonatal cephalic, cardiac pediatric, peripheral vessel	Body surface
CW2s	Pencil probe	Pediatric, adult cephalic, cardiac adult, cardiac pediatric, peripheral vessel	Body surface
CW5s	Pencil probe	Pediatric, cardiac pediatric	Body surface
SP5-1s	Phased	Abdominal, pediatric, neonatal cephalic, adult cephalic, cardiac adult, cardiac pediatric	Body surface

Some of the probes have corresponding needle-guided brackets for biopsy. The available probes and the corresponding needle-guided brackets are listed as follows:

Probe model	Needle-guided Bracket Model	Biopsy angle/depth (±1°)	Applicable Biopsy Needle
V11-3Ws	NGB-004 metal/needle non-detachable	/	16G, 17G, 18G
L12-4s/ L14-6Ns	NGB-007 plastic/needle detachable metal/needle detachable	40°, 50°, 60°	Metal: 14G, 16G, 18G, 20G, 22G Plastic: 13G, 15G, 16G, 18G, 20G
SP5-1s	NGB-011 metal/needle non-detachable	11°, 23°	13G, 15G, 16G, 18G, 20G
C11-3s	NGB-018 metal/needle detachable	15°, 25°, 35°	14G, 16G, 18G, 20G, 22G
C5-1s	NGB-022 metal/needle detachable	25°, 35°, 45°	14G, 16G, 18G, 20G, 22G

2.5.3 Options

No.	Item		Remarks
1.	Footswitch		Types: 1-pedal/2-pedal/3-pedal
2.	Mobile Trolley See chapter "Appendix E Trolley" for details.	UMT-500 (without power supply or battery)	/
		UMT-500Plus (with power supply and battery)	
3.	Probe Extend Module		PEM-51
4.	Clamp-type three-cable ECG lead (electrode cable)		ECG function should be configured.
5.	DC-IN cable		ECG function should be configured.
6.	Audio/Video Extend module		iDock51
7.	IMT		Vascular Package should be configured.
8.	USB to LAN Adapter		/
9.	iScape View		/
10.	Free Xros M		/
11.	Free Xros CM		/
12.	CW		/
13.	Tissue Doppler Imaging (TDI)		/
14.	TDI QA		TDI should be configured.
15.	LVO		/
16.	Elastography		/
17.	Stress Echo		Cardiology Package should be configured.
18.	Tissue Tracking QA		Cardiology Package should be configured.
19.	iWorks		/
20.	iNeedle		/
21.	Abdomen/General Package		/
22.	Obstetrics Package		/
23.	Smart OB		Obstetrics Package should be configured.
24.	Smart NT		Obstetrics Package should be configured.
25.	Gynecology Package		/
26.	Cardiology Package		/
27.	Small Parts Package		/
28.	Urology Package		/
29.	Vascular Package		/

No.	Item	Remarks	
30.	Pediatrics Package	/	
31.	Nerve Package	/	
32.	Emergency & Critical Package	/	
33.	DICOM	DICOM Basic	/
		DICOM Worklist	DICOM Basic should be configured.
		DICOM MPPS	
		DICOM OB/GYN SR	
		DICOM Vascular SR	
		DICOM Cardiac SR	
		DICOM Query/Retrieve	
DICOM Breast SR			
34.	Physio function(ECG)	Clamp-type three-cable ECG lead and DC IN cable should be configured.	

2.5.4 Peripherals Supported

No.	Item	Model
1.	Digital graph/text printer	HP Deskjet 1050 J410 series HP Officejet 7000 wide format HP Officejet Pro 8100
2.	Black / white video printer(digital)	MITSUBISHI P95DW-N SONY UP-D897 SONY UP-D898MD SONY UP-X898MD
3.	Digital color video Printer	SONY UP-D25MD
4.	Barcode reader	SYMBOL DS6707-SR SYMBOL LS2208-SR
5.	DVR	
6.	External DVD R/W drive	ASUS DVD

Note: printer SONY UP-D898MD and SONY UP-X898MD drivers are not installed on the ultrasound system in factory.

■ Parts that can be used within patient environment:

- Main unit.
- Probes.
- Footswitch.
- Printers: MITSUBISHI P95DW-N, SONY UP-D897, SONY UP-D25MD





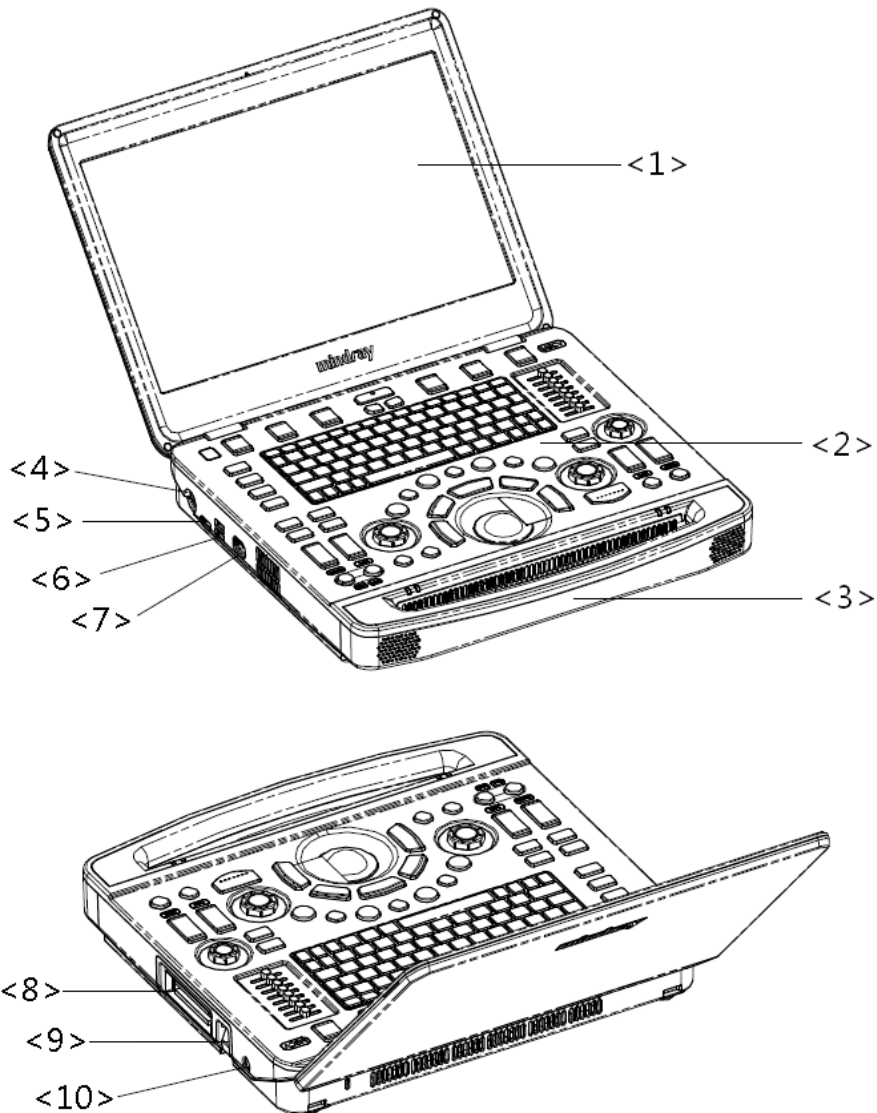

WARNING:

This system complies with IEC60601-1-2:2007, and its RF emissions meet the requirements of CISPR11 Class B. In a domestic environment, the customer or user should ensure the system is connected to Class B peripheral devices, otherwise RF interference may occur, and the customer or user must take adequate measures accordingly.

2.6 Introduction of Each Unit



No.	Name	Function
1	Display	Displays the images and parameters during scanning.
2	Control Panel	Operator-system interface or control
3	Handle	Used for carrying the system
4	Power input port 12V \equiv 9A (Max.)	Connects the power adapter

No.	Name	Function
5	HDMI port	Outputs high definition multimedia signal
6	USB port 	Connects USB devices (2)
7	ECG port	Connects ECG lead or DC-IN cables.
8	Probe port 	Connects a probe to the main unit; or connects a probe extend module
9	Probe locking lever	Locks or unlocks the probe connected with the main unit  : locked symbol  : unlocked symbol
10	Pencil probe port	Connects a pencil probe.

2.7 Extend Module

Extension modules to the system are: probe extend module (PEM-51) and audio/video extend module (iDock51).

2.7.1 Probe Extend Module

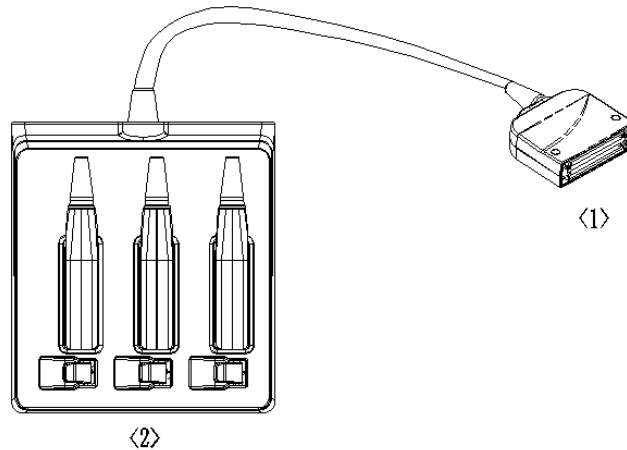

No.	Name	Function
<1>	Connector	Connects to the probe port of the main unit, and extends the probe port to three.
<2>	Probe port	To extend ports for connecting probes, the middle one is a docking port

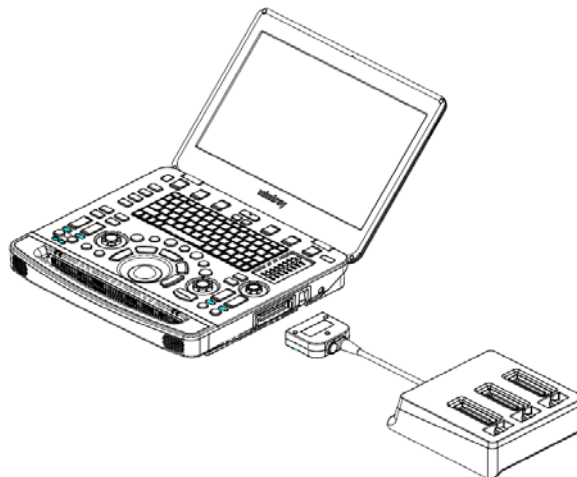

- Note:**
1. Perform the plug and unplug of the probe module. To reduce the wastage of probe module, the operation should be conducted under frozen status of the system.
 2. If you use the probe extend module to connect a probe, the image quality may be degraded.

2.7.2 Audio/Video Extend Module

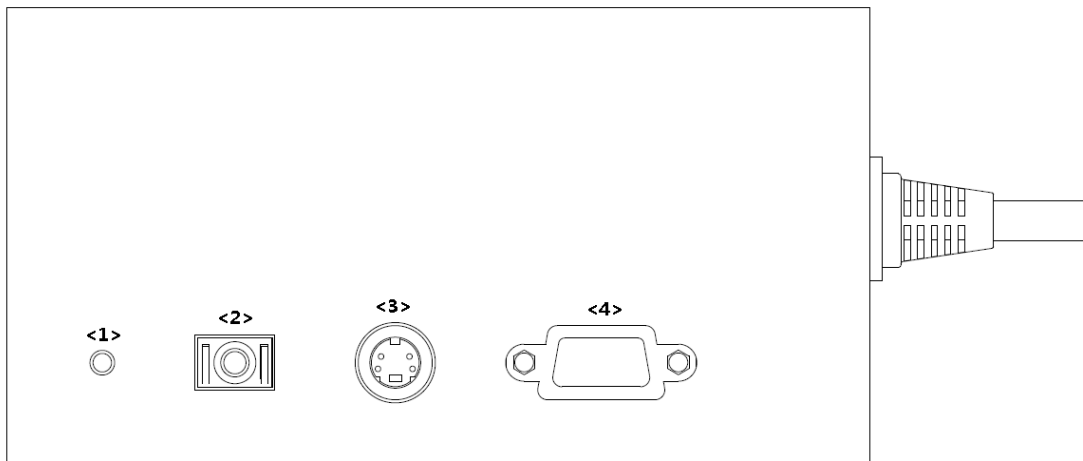

No.	Symbol	Function
<1>	Indicator	It illuminates in green when the module is connected to the main unit.
<2>		Used for audio signal output.
<3>		Used for separate video output.
<4>	VGA	VGA signal output

- Connection

Connect the Audio/Video extend module to the main unit via a HDMI port. As shown in the following figure.

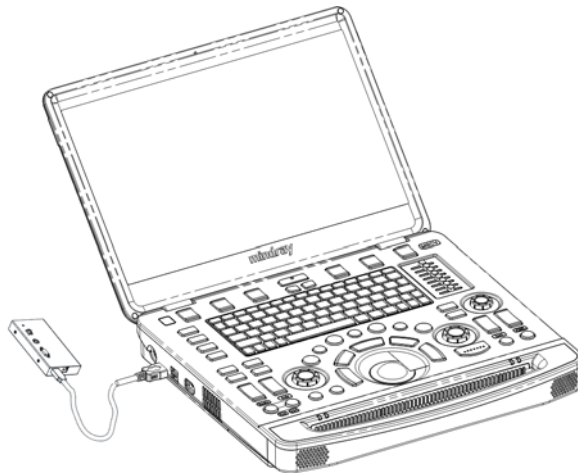

NOTE: When connecting an external video device (HDMI/VGA), make sure the display resolution setting is 1920x1080, otherwise the image quality may be degraded.

For a better audio/video signal performance, please connect the iDock51 to the ultrasound system before the system is powered on.

2.8 Control Panel



No.	Name	English Name	Description
1.	B mode button	B	Press to enter B mode.
2.	P mode button	P	Press to enter Power mode.
3.	C mode button	C	Press to enter Color mode.
4.	CW mode button	CW	Press to enter CW mode.
5.	PW mode button	PW	Press to enter PW mode.
6.	TDI Functional buttons	TDI	Press to enter TDI mode
7.	M mode button	M	Press to enter the M mode.
8.	Update button	Update	Switching key: Press to change the currently active window. Start or end capturing the image in iScape.
9.	Measure button	Measure	Press to enter/exit application measurement.
10.	Caliper button	Caliper	Press to enter/exit general measurement.
11.	Trackball	/	To move the cursor.
12.	Confirm key (left <Set> key)	/	Press to confirm the operation.
13.	Confirm key (right <Set> key)	/	
14.	Angle adjustment and quick angle knob	Angle	Adjust the angle.
15.	Gain and iTouch knob	iTouch	Adjust the gain of the image in various modes Press to enter iTouch mode.
16.	Cine button	Cine	Press to enter the Cine Review status from non-cine status when there is a multi-frame cine file playing.
17.	Clear button	Clear	Press to clear off the comments or measurement calipers on the screen.
18.	Freeze button	Freeze	Press to freeze or defreeze the image.
19.	Power button	/	Power the power supply on/off.
20.	Soft menu adjustment button 1	/	Press to select the soft menu items displayed on the bottom of the screen. Refer to the subsequent contents for specific functions.
21.	Soft menu adjustment button 2	/	
22.	Soft menu adjustment button 3	/	
23.	Soft menu page up button	/	Press to turn the soft menu page backwards.

No.	Name	English Name	Description
24.	Soft menu page down button	/	Press to turn the soft menu page forwards.
25.	Soft menu display mode switch button	/	Press to switch the mode for the soft menu.
26.	Soft menu adjustment button 4	/	Press to select the soft menu items displayed on the bottom of the screen. Refer to the subsequent contents for specific functions.
27.	Soft menu adjustment button 5	/	
28.	Soft menu adjustment button 6	/	
29.	Patient information button	Patient	Press to enter the Patient information screen.
30.	Probe/exam mode switch button	Probe/Exam	Press to switch probe and exam mode.
31.	Image review button	Review	Press to review the stored images.
32.	End exam button	End Exam	Press to end an exam.
33.	User-defined key 3	P3	Undefined button, set by the user in preset.
34.	User-defined key 2	P2	Undefined button, set by the user in preset.
35.	Body mark button	Body Mark	Press to enter/ exit the body mark mode.
36.	Cursor button	Cursor	Press to show/hide the cursor.
37.	Baseline position adjustment button and auxiliary interface	Baseline	Adjust the baseline parameter when the indicator is on.
38.	Scale adjustment button and auxiliary interface	Scale	Press to adjust the scale parameter when the indicator is on.
39.	Steer/Invert adjustment button	Steer/Invert	Adjust the steer/invert parameter when the indicator is on.
40.	TGC and functional interface	/	Move to adjust depth gain compensation.
41.	Single-window button	Single	Press to enter active window in Dual or Quad mode.
42.	Dual-split window button	Dual	Press to enter the Dual mode from another mode; Press to switch between the two windows in the Dual mode.
43.	Image zoom and spot/pan zoom switch knob	Zoom	Press to enter or exit zoom status. See “6.2 Image Magnification” chapter for details.
44.	Depth adjustment button and functional interface	Depth	Adjust the depth parameter when the indicator is on.

No.	Name	English Name	Description
45.	Focus position adjustment button and functional interface	Focus Position	Adjust the focus position when the indicator is on.
46.	Save static image button	Save	Save images in a preset way.
47.	User-defined key 1	P1	Undefined button, set by the user in preset.
48.	Standby status indicator	/	Standby indicator. Standby: blinking in orange. Other status: light off.
49.	Hard disk read indicator	/	Hard disk status indicator. The indicator blinks in green when hard disk is running. The indicator is off on the other status. NOTE: DO NOT move the machine when the indicator blinking in green. Otherwise the hard disk may be damaged by sudden shake.
50.	Battery indicator	/	Battery status indicator. ■ Charging status: It illuminates in orange when batteries are charging; It illuminates in green when batteries are charged fully. ■ Discharging status: It illuminates in green color when the power of the batteries is sufficient; It illuminates in orange color for low battery power.
51.	AC power indicator	/	AC indicator The indicator is green at AC supply. The indicator is off when batteries are supplied without AC supply.
52.	Esc	Esc	Cancel the operation or exit the operation.
53.	On-line help	Help	Press to open or close the accompanying help documents.
54.	Patient data management system	iStation	Enter or exit patient information system.
55.	Report	Report	Open/ close the exam report.
56.	User-defined key 5-8	P5~P8	Undefined button, set by the user in preset.
57.	Stress echo	Stress Echo	Press to enter Stress Echo mode.
58.	Physiological signal	Physio	Press to enter or exit ECG or respiratory curve.
59.	Setup	Setup	Press to enter/ exit Setup.

No.	Name	English Name	Description
60.	Biopsy	Biopsy	Press to enter biopsy.
61.	Set home	Set Home	Set home of comments.
62.	Quad-window display	Quad	Enter Quad mode in Non-Quad mode; Press to switch among interfaces in Quad mode.
63.	iZoom (Full-screen Zooming)	iZoom	Enter/exit full-screen zoom status; Under iZoom status, switch zooming way.
64.	Arrow	Arrow	Enter/exit the arrow comment status.
65.	Home	Home	Activate the Home function: return to start position of comment.
66.	Comments	Comment	Enter/exit the textual comment status.
67.	Direction-control keys	/	Moves the cursor one letter each time; or, select the ambient one in a selectable area.
68.	User-defined key 4	P4	Undefined button, set by the user in preset.
69.	Alphanumeric keys	/	Enter characters.

■ Functions of key combinations

The system supports multi-language input using key combinations. Key combinations include [Shift], [Alt Gr], [Ctrl] and some alphabet keys.

























- <Shift> key
 <Shift> + key: enter the top left letter on the key.
 For the alphabet keys (<A>~<Z>), press <Shift> + key to enter the current letter in a different case.
- [Alt Gr] key
 Combined with other letter keys, [Alt Gr] can be used for entering other languages.
 Press [Alt Gr] and a letter key simultaneously. The letter in the top-right corner of the key is entered.
- [Ctrl] key combined keys
 On the iStation or Review screen, use <Ctrl> and <Set> to select more than one patient.
- [Fn] key

For these combination keys, press <Fn> + key to use the functions indicated with a frame on the key.

No.	Fn+	Name	Function
1.	→	/	Increase the audio volume.
2.	←	/	Decrease the audio volume.
3.	↑	/	Increase the brightness of the screen.
4.	↓	/	Decrease the brightness of the screen.

2.9 Symbols

This system uses the symbols listed in the following table. Their meanings are explained as follows:

Symbol	Description
	Type-BF applied part
	Caution !
	No user serviceable parts (applied to the power adapter)
	Indoor, dry location use only (applied to the power adapter)
	Dangerous voltage
	Transducer sockets
	Battery status indicator
	Pencil probe port
	AC (Alternating current)
	Functional grounding
	Equipotentiality
	protective earth
	Foot switch
	USB port
VGA   	Used for VGA input.
ECG	Used for ECG function
	Used for separate video output
	Used for audio output.
HDMI	High definition multimedia interface.
	When the lever located at the bottom of the monitor support arm points to  , you can move the monitor to the right and left.
	When the lever located at the bottom of the monitor support arm points to  , the supporting arm is fixed in the middle position.
	Product serial number
	Manufacture date

3 System Preparation

3.1 Move/Position the System

Read and understand the safety precautions before positioning the system to ensure the safety of both the operator and the devices.

1. Switch off the power, and pull out the power plug.
2. Disconnect all cables from off-board peripheral devices.
3. Place the system in a desired location.
4. Leave at least 20cm at the back and both sides of the system..



CAUTION:

Maintain a generous, free air flowing space around the back and both sides of the system. Not doing so may result in failure due to the increased rise in the system's operating temperature.

3.2 Power ON/OFF

3.2.1 Power the System ON

 **CAUTION:** To ensure safe and effective system operation, you must perform daily maintenance and checks. If the system begins to function improperly, immediately stop scanning. If the system continues to function improperly, fully shut down the system and contact the Mindray Customer Service Department or a sales representative. If you use the system in a persistent improperly functioning state, you may harm the patient or damage the equipment.

■ Check before Powering ON

Check before the system is powered on:

No.	Check Item
1	The temperature, relative humidity and atmospheric pressure meet the requirements of the operating conditions. See “2.4.3 Environmental Conditions” for details.
2	There is no condensation.
3	There is no distortion, damage or dirt on the system and peripheral devices. If any dirt is found, cleaning shall be performed as illustrated in section “17 System Maintenance.”
4	There are no loose screws on the monitor, control panel or the trolley.
5	There is no cable damage (e.g., power cord). Maintain secure connections to the system at all times.
6	The probes and probe cables are free from damage or stains. See chapter “13 Probes and Biopsy” for details of probe cleaning and disinfection.
7	No miscellaneous odds and ends are attached or affixed to the control panel.
8	Ensure that all connections are free from damage and remain clear of foreign object blockages. There are no obstacles around the system and its air vent.
9	Probe cleaning and disinfection.
10	The entire scanning environment and field must be clean.
11	The locking mechanism of the casters(if there is a trolley) works normally.

■ Check the system after it is powered on

Press the power button at the top-left corner of the control panel to power the system on.

Check after the system is powered on:

No.	Check Item
1	There are no unusual sounds or smells indicating possible overheating.
2	There are no persistently displayed system error messages.
3	There is no evident excessive noise, or discontinuous, absent or black items in the B mode image.
4	Check whether there is abnormal heat on the surface of the probe during an ultrasound procedure. If you use a probe which is giving off excessive heat, it may burn the patient.
5	The control panel keys and knobs are fully functional.

No.	Check Item
6	The date and time are displayed correctly.

 WARNING:	If you use a probe giving off excessive heat, it may burn the patient. If you find anything not functioning properly, this may indicate that the system is defective. In this case, shut down the system immediately and contact Mindray Customer Service Department or sales representative.
---	--

Note:	When you start the system or switch between transducers, you will hear clicking sounds – this is expected behavior.
--------------	---

3.2.2 Power the System OFF

You must follow the correct procedures to power the system off. Also, after you upgrade the software or when the system is down, you need to power off and restart it.

If you will not use the system for a long period of time, you shall:

1. Disconnect the power adapter.
 2. Disconnect the mains power.
 3. Turn off powers of all peripherals connected to the system.
 - To power the system off normally
1. Press the power button in the top-left corner of the control panel to see the option:
 - Shut down: to power the system off normally.
 - Standby: to enter standby status.
 - Cancel: to cancel the operation.

2. Select [Shut Down] to power the system off.
 - To shut down the system directly if it cannot be done normally:

Press and hold the power button for a long time and the system will power off without displaying the “Shutdown Confirm” screen. However, shutting down the system this way may destroy the data.

NOTE: DO NOT rush direct shutdown of the system. It may damage the data. After the system is upgraded, use “Shut Down” to power the system off to make the upgraded data effective.

3.2.3 Standby

- To enter standby:
 - Fully fold the LCD display and wait for 30 sec, then the system enters the standby status.
 - Open [Setup]->[System Preset]->[General] to set the time for screensaver and standby. If the system is not carrying out an operation, the screensaver appears after the screensaver delay period. If there is still no operation, the system enters standby after the standby delay period.
 - Press the power button and select “Standby”.
- To exit standby:
 - Unfold the LCD display.
 - Press the power button.
- Under the standby status:

Press the power button to exit standby status and power off the system after 5s.

NOTE: Power off the system if you will not use the system for a long period of time (including storage/ transportation condition), and you should not allow the system in standby status, otherwise the batteries will be out of power and permanently damaged.

If the system will not be used for a long period of time, you should disconnect the power adapter, disconnect the mains power, and turn off the power to all peripherals connected to the system.

3.3 Connecting the Power Cord

This system can work normally only when it is connected to the external power supply or the battery capacity is sufficient.

3.3.1 Connecting Power

1. Connect the connector of the power adapter to the adapter port in the system.
2. Use a three-wire cable to connect the adapter with the external power supply.
3. The external power supply must meet the following requirements:
 - Voltage: 100-240V~
 - Power supply frequency: 50/60Hz
 - Power input: 2.0A max

If you have any question about the power adapter, please contact your sales representative.

NOTE: You must use the specified power adapter.

Do not use this power adapter in the conditions other than those specified.

3.3.2 Powered by Batteries

- When connected to the external power supply, the system is powered by the external power. The lithium ion batteries inside it are in the charging status.
- When disconnected from the external power supply, the system is powered by the lithium ion batteries. Refer to Appendix B Battery for the detailed operations and precautions.

3.4 Connecting a Probe



CAUTION:

Press <Freeze> to freeze an image or turn off the system power before connecting or disconnecting a probe. Failure to do so may result in system or probe failure.

When connecting or disconnecting a probe, place it in the proper position to prevent the probe from falling off or becoming damaged.

Only use probes provided by Mindray. Aftermarket probes may result in damage or cause a fire.

3.4.1 Connecting a Probe



WARNING:

The probes, cables and connectors should be in proper operating order and free from surface defects, cracks and peeling. Otherwise, this may lead to electrical shock.

1. Keep the cable end of the transducer to the right side of the system, insert the connector into the system port, then press in fully.
2. Toggle the locking lever to the top position.
3. Position the probe properly to avoid it being treaded on or becoming wrapped around other devices. DO NOT allow the probe head to hang free.

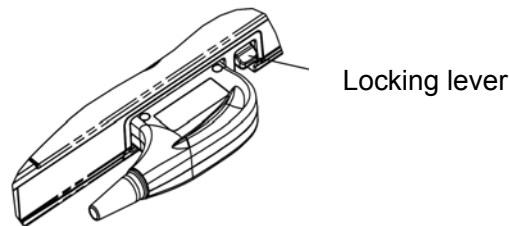

NOTE:

Before inserting the connector into the probe port, inspect the connector pin. If the pin is bent, do not use the probe until it has been inspected/repaired/replaced.

3.4.2 Disconnecting a probe

1. Turn the locking lever 90° counterclockwise to the horizontal position.
2. Pull the transducer connector straight out vertically (shown in the figure below).

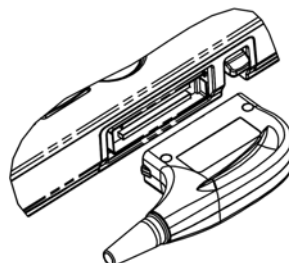

3.5 Connecting the Footswitch



The system supports USB port-type foot switches.



The function of the foot switch can be preset. For details, see “12.1.6 Key Configuration.”

3.6 Connecting USB Devices

⚠ WARNING: DO NOT directly remove a USB memory device, as the USB device and/or the system may become damaged.

- When connecting a USB memory device to the ultrasound system via a USB port, a sound is heard if it is connected successfully and the symbol  appears in the bottom-right corner of the screen.
- To remove the USB device: click  to open the [Remove USB Device] screen. Select the device to be removed and click [OK]. A sound is heard when removing the USB memory device.
- The system supports option of external DVD R/W drive. The DVD R/W drive is connected to the ultrasound system via USB port.

NOTE: When connecting an external DVD R/W drive, connect the two cables of the drive to the ultrasound system or USB ports on the trolley if the drive provides 2 USB power cables. In this way, the DVD R/W drive can work more normally.

If the USB disk cannot be recognized by the system, please try disconnecting and then connecting again several times, or try another USB disk. If the problem still exists, please contact Mindray service engineer.

3.7 Installing a Printer

3.7.1 Installing a Graph/Text Printer

- Connecting a local printer

Note: Printers listed in “2.5.4 Peripherals Supported” Chapter have drivers installed already.

As shown in the figure below, a graph / text printer has a power cord and data cable. The power cord shall be directly plugged into a well-grounded outlet.

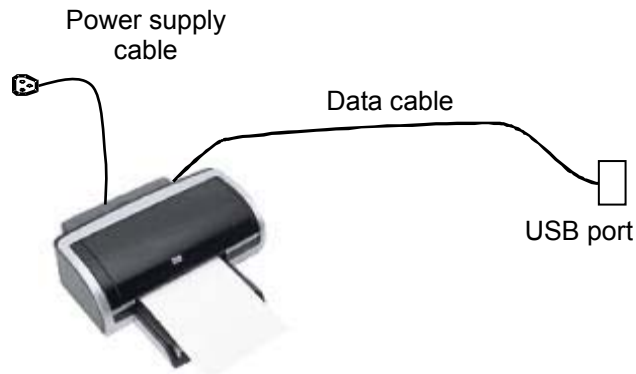

1. Connect the data cable to the USB port on the ultrasound system.
2. Power the system and the printer on.
3. Put the installation optical disk of the printer driver into the external DVD R/W drive.
4. Install the printer driver: Select [Setup]→[Print Preset]→[Add Printer].

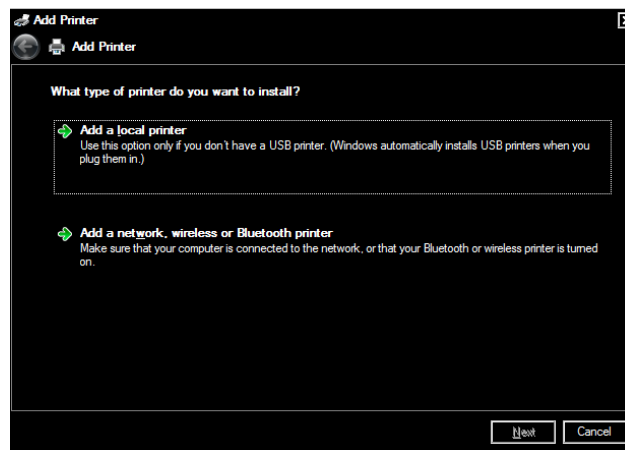

Note: all the operations are finished with left <Set> key.

5. Select [Add a local printer] and click [Next] to enter the screen used for browsing driver.

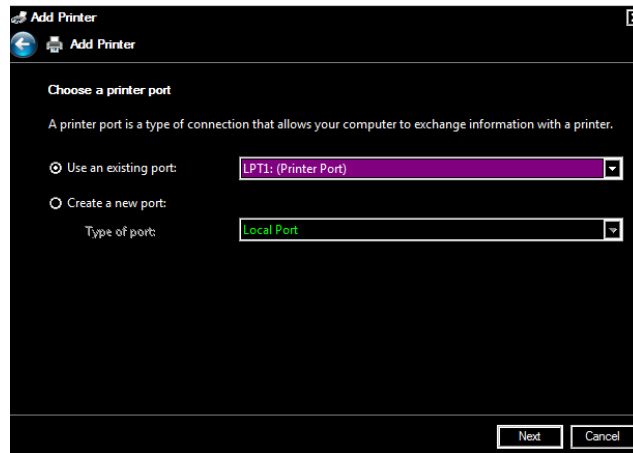

Note: see the printer's operation manual to select the port, or try to use the default port of the system.

6. Click [Have Disk] to find the driver path (the installation type should be WIN7 64), and then click [Next] to install the driver.

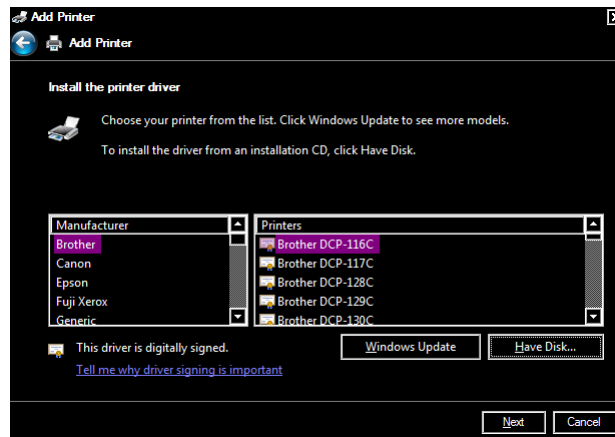

7. Complete the operation according to the tips on the screen. Click [Finish] to end the installation.

■ Add network printer

1. As the system is connected into a LAN, open [Setup]-> [Printer Preset] screen.
2. Click [Add Printer], select [Add a network, wireless or Bluetooth printer].
3. The system starts to search all available printers within the network. Select the target printer and click [Next], the system tries to connect to this printer.
4. When the connection is successful, the system prompts the dialogue box, click [Next] according to the screen tips and then click [Finish].The printer is installed successfully.

Tips: the system has combined many types/brands of printer drivers, if targeted printer drive is not included in the system, you may need to install the driver for the network printer. Please use the optical disk or U disk with the driver to install according to the system prompts.

NOTE: When you install the printer's driver, you must specify the specific path for installation. A vague path may result in longer searching times.

The network printer functions depending on the configured network environment in the hospital, please consult the network configuration manager in case of failure.

■ Print

Both report and image can be printed on a graph / text printer.

To set the default report printer and its attribute:

In "[Setup]→[Print Preset]" screen, select the "Report Print" column in the service list. You can select printer from the driver list next to "Printer" in the lower screen and set the items in the "Property" box. Click [Save] after you have finished setting.

Please refer to the accompanying manuals of the printers for more details.

3.7.2 Installing a Video Printer

The system support video printers, consist of the B/W digital printers and color digital printers.

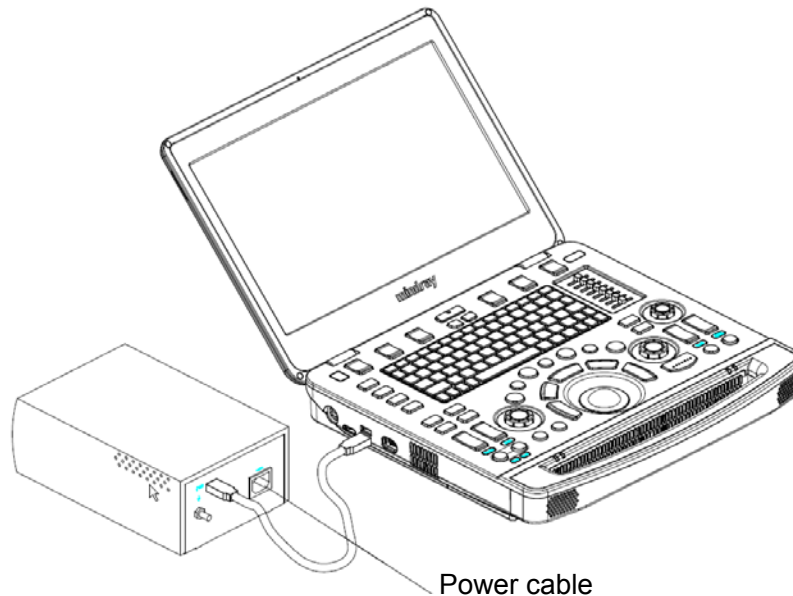

1. Position the printer in the proper place.
2. Plug the printer power cord into an appropriate outlet.
3. Use a USB cable to connect between the system's USB port and the printer's USB port.
4. Load a paper roll, and turn on the system and printer.
5. See section "3.7.1 Installing a Graph/Text Printer" for the driver installation procedure (printer drivers listed in chapter "2.5.4 Peripherals Supported" are installed already).
6. Add a print service:
 - (1) Open the "[Setup] → [Print Preset]" screen.
 - (2) Click [Add Service] to enter the page.

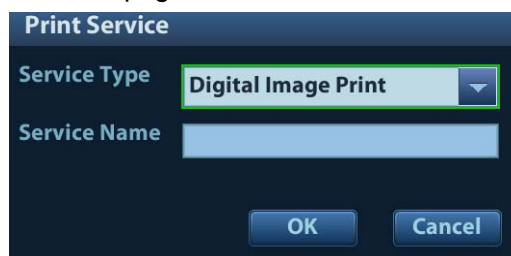

- (3) Select the service type and enter the service name manually.
- (4) Click [OK] to return to the page.
- (5) Select the target printer from the drop-down list in the "Property" box and set other printing properties.
- (6) Click [Save] to complete.

3.8 Wired Network Connection

Connect the USB plug of the USB to LAN Adapter to the USB port on the machine, and insert the network cable into the LAN port of the adapter to get a wired network connection.

WARNING The LAN port of the adapter **CAN ONLY** be used to connect to wired network. Device interconnection using the adapter through LAN port is forbidden; otherwise, electric shock may result. If you intend to connect an external device, please make sure it meets the requirement of STANDARD GB9706.15 or *IEC60601-1:2005 chapter 16*.

Tips: for a better network transfer performance, see “Appendix A Wireless LAN” for details about network setting.

3.9 Basic Screen & Operation

3.9.1 Screen Display

The screen displays ultrasound images, parameters, menus and measurement results windows.

The following diagram maps out the different areas, such as patient information, image parameter & menu, image area, thumbnail of images saved, help information & cursor icon, soft menu, system status icon, etc.

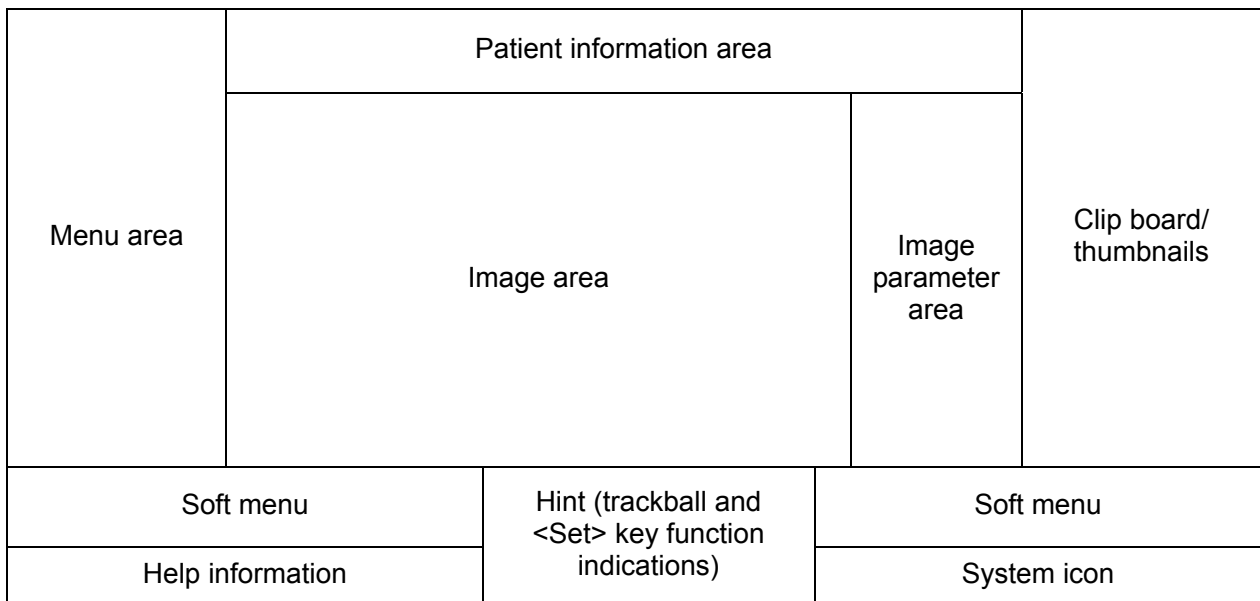

■ Patient/Exam information

The Information area consists of the manufacturer's logo, the hospital name, the exam time, patient information, the probe model, the exam mode, etc. To preset which kind of patient information is displayed, enter the path: Setup→System Preset→General. For more details, please refer to "12.1.2 General" chapter.

- Hospital name
Display the hospital name. Hospital name can be set via "[Setup] → [System Preset] → [Region]".
- Patient Information
Displays patient name, ID, gender and age etc. Enter the patient information through the "Patient Info" screen. Or, import the saved patient data from DICOM/HL7 Worklist server. See "4.1 Patient Information" chapter for details.
- Exam Mode
Displays the currently used exam type, e.g. Abdomen, is displayed.
- Probe Model
Display the currently-used probe model, or the default model.
- Exam time
Displays the exam time, including date and time. Exam time can be set via "[Setup]→[System Preset]→[Region]". Exam time will be frozen with the frozen image.
- Operator
Displays the operator's name on the screen. This information is entered through the "Patient Info" screen.
- ECG icon
Displays ECG icon, which consists of a heart icon and heart rate, e.g. "♥75bpm"

■ Menu area

Includes the image menu, measurement menu, comment menu, body mark menu, and so on. The menu area consists of menu title, menu items and page-turning button. As shown in figure below.

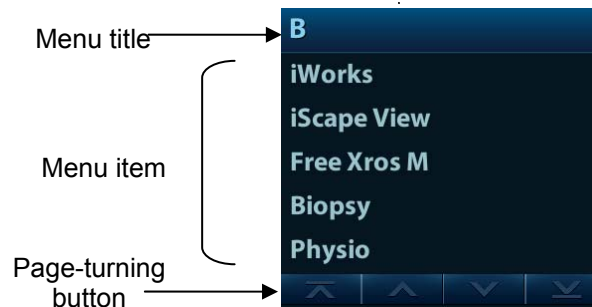

- Menu title
Displays the menu name.
- Page-turning button
When there are too many items in a menu, the items will be divided into more than one page. You can turn pages by page-turning buttons.
- Menu item
Refers to the items on a menu. Items of measurement can be preset (See Advanced manual for details).

■ Image area





The image area displays the ultrasound images, ECG waveforms, probe mark (or activating window mark "M9"), coordinate axis (including depth, time, velocity/frequency), acoustic output index (top-left part of the image area, including the acoustic power, MI and TI index) and focal position (located on the depth axis in the form of ). Annotations, body marks, measurement calipers, color bar/grayscale bar are also displayed here.

■ Parameter area

Displays the image parameters for the active window. If there are more than one imaging modes, the parameters are displayed by each mode.

■ Clip board/Thumbnails

Displays the thumbnail images stored under the current patient.

- Page-turning: when there are more than one page images have been stored, you can turn to the next or preview page by  or  respectively.
- Delete: select a thumbnail image, and click  to delete it.
- Send to: select a thumbnail image, and click  to send it to other devices.

■ Help information area

The help information area displays various help information items or the progress bar in the current status.

Tip: In terms of help information, "TB" refers to "Trackball".

Press <Help> to open the Help Info manual.

■ Soft Menu Area

The soft menu items displayed are corresponding to functions of soft menu controls (soft key) in the control panel.

The soft menu controls are located at the top of the control panel, shown in the following figure.

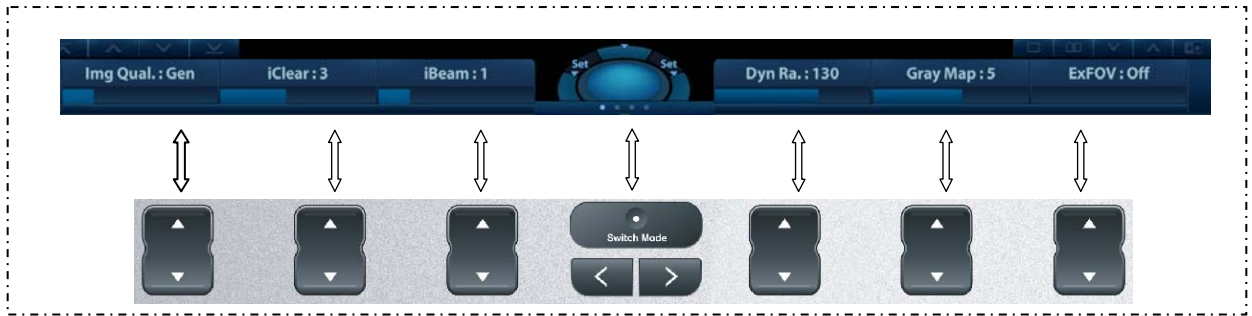

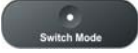
- Page-turning: Use the left/right keys on the control panel to turn pages.
- Mode switching: Use  to switch between the modes. The soft menu items vary depending on the mode. The mode navigation will cause the change of the menu.
- The soft menu items are operated respectively through the groups of soft menu controls.

■ System status icon

This area displays the relevant system icons, such as USB memory device, printer, network, and current system time, etc.

■ Trackball function hint area

Displays the current functions of trackball and keys, as shown in the following figure:



The hint area indicates functions of the left/right <Set> key and current modes. Current status is also depicted by the system status icon.

■ Other Operations

The positions of areas illustrated here are not fixed. They can be moved within a certain area on the monitor using the trackball.

- Results window
- Comments
- Body marks

3.9.2 Basic Operations of the Dialog Box

A dialog box screen consists of a title, page tabs, contents and buttons, as shown in the figure below:

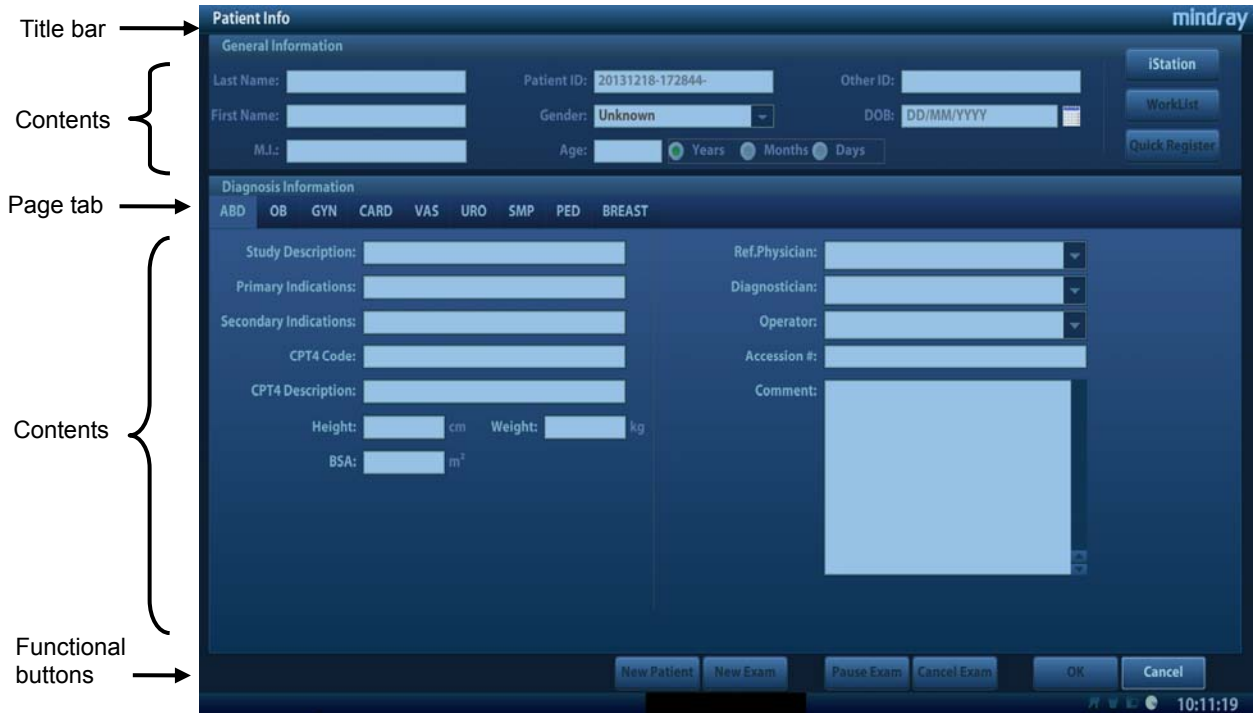

Composition	Description
Title Bar	The title bar is used to give a description of the content and function of the screen.
Page Tab	For some screens, the contents are distributed across several pages. Use the <Set> key to open/close the available pages.
Contents	<ul style="list-style-type: none"> ■ Radio box: click to select the item. ■ Check box: click to check or uncheck the item. ■ Entry box: enter characters manually using the keyboard. ■ Drop-down list box: click ▼ to show the list and select an item.
Functional buttons	When a screen's operation is complete, click the [OK] or [Cancel] button to save or cancel the operation, and close the screen.

■ To reposition a dialog box which is not a full-screen dialog box:

1. Roll the trackball to move the cursor over the title bar of the dialog box. The cursor becomes a . Press the <Set> key.
2. Roll the trackball and position the rectangular graphic in the new desired location.
3. Release the <Set> key, and the dialog box is moved to the desired position.

4 Exam Preparation

A patient exam can be started as per the following situations:

- New patient information: to start a new patient exam, patient information must first be entered.
- New exam: to start a new exam for patient who is already registered, the recorded information can be obtained through either iStation or Worklist.
- Activate exam: to select an exam that has been completed within 24 hours, continue the exam with imported patient information and exam data.
- Continue an exam: to select an exam that has been paused within 24 hours, continue the exam with imported patient information and exam data.

General procedure for an exam:

Enter the patient information → select an exam mode and probe → Choose an imaging mode → Start the exam.

- The system supports image scanning and measurement without patient information.

4.1 Patient Information

To start a new patient exam, it is best to enter detailed patient information. The system will set up a unique information database for each patient based on the patient information entered, so that the information of one patient will not be confused with that of another patient.



CAUTION:

Before examining a new patient, press the <End Exam> key to end the exam of the previous patient. Update the patient ID and information to avoid mixing data between patients.

- To enter the Patient Info screen
 - Press <Patient>.
- To exit the Patient Info screen
 - Click [OK] on the Patient Info screen or press <Patient> on the control panel.
 - Click [Cancel] on the Patient Info screen. Or press <Esc> on the control panel to exit the screen without saving any of the entered patient data.
 - Press or <Freeze> to return to the current exam mode and save the entered information.
- Click [Quick Register] on the screen to quickly save the patient information and return to the main screen.

4.1.1 New Patient Information

The Patient Info screen is shown as follows:

Place the cursor over the desired box. The field box is highlighted and a flashing cursor appears. Information can be entered or selected from the options.

You can also change the cursor's position using <Tab>, <Enter> or the up/down controls.

Information includes:

1. General information

- Patient ID

The Patient ID is generated automatically by the system after starting a new patient, and can be modified manually.

The ID can also be obtained using the bar code reader.

- Name

Enter the patient's name using the keyboard.

- Gender

Select Male, Female or Unknown for patient gender from the drop-down list.

- DOB (date of birth):

You can either enter the patient's date of birth manually,

Or click  to select the date, and click [OK] to finish.

- Age

- Auto-generated age: once the DOB is obtained, the system displays an auto-generated age in the field box. The unit can be "Years", "Months" or "Days." If the age is less than one year, the system will automatically calculate the age in months or days.

- You can also enter the age manually.

NOTE: When you enter dates manually, enter them in same the format as that of the system.

2. Exam Type

■ Exam application type

You can select from: ABD (Abdomen), OB (Obstetrics), GYN (Gynecology), CARD (Cardiac), VAS (Vascular), URO (Urology), SMP (Small Part), PED (Pediatrics) and BREAST (Breast).

Select the exam type tab to enter exam-specific information.

■ General information:

Study description:	To enter a description for each exam.
Primary indications:	To enter the primary indications (reason for performing the exam.)
Secondary indications:	To enter the secondary indications.
CPT4 code:	To enter the CPT4 code.
CPT4 description:	To enter the CPT4 description.
Remarks:	Exam-specific explanation or remarks.

■ Exam-specific information:

Exam Type	Information	Description
ABD (Abdomen)	BSA (body surface area)	After the height and weight are entered, the system will automatically calculate the BSA based on the formula which is set via "[Setup] → [System Preset] → [General]."
OB (Obstetrics)	Calculation index	<p>Calculate the gestation age (GA) and estimated delivery date (EDD) based on the last menstrual period (LMP), date of conception (DOC), in vitro fertilization (IVF), basic body temperature (BBT) and previous exam date (PRV). Select LMP, DOC, IVF, PRV, BBT, or EDD from the drop-down list, or calculate the GA and LMP according to the EDD and entered date.</p> <ul style="list-style-type: none"> ● LMP: after you enter the LMP, the system will calculate the GA and EDD. ● DOC: after you enter the DOC, the system will calculate the GA and EDD. ● IVF: after you enter IVF, the system will calculate the GA and EDD. ● PRV: enter the date and GA of the last exam, the system will calculate a new GA and EDD. ● BBT: enter the BBT, the system will calculate the GA and EDD. ● EDD: after you enter the EDD, the system will calculate and display the GA and LMP.
	Gravida	Times of pregnancy.
	Ectopic	Times of abnormal pregnancy, e.g., extrauterine pregnancy
	Gestations	Number of embryos (1, 2, 3, 4)
	Para	Times of delivery.
	Aborta	Times of abortion.

Exam Type	Information	Description
GYN (Gynecology)	LMP	Last menstrual period.
	Gravida	Times of pregnancy.
	Para	Times of delivery.
	Ectopic	Times of abnormal pregnancy, e.g., extrauterine pregnancy.
	Aborta	Times of abortion.
CARD (Cardiology)	BSA (body surface area)	After the height and weight are entered, the system will automatically calculate the BSA based on the formula which is set via "[Setup] → [System Preset] → [General]."
	BP	Blood pressure.
	HR	/
	RA Press.	Right Atrium Pressure.
VAS (Vascular)	BP(L) (blood pressure)	Input left blood pressure.
	BP® (blood pressure)	Input right blood pressure.
URO (Urology)	Serum PSA	/
	PPSA coefficient:	/
SMP (Small Parts)	None	/
PED (Pediatrics)	None	/
Breast	None	/
General information	Height	/
	Weight	/

3. Operating Information

Accession #: refers to the exam number used in DICOM.

Diagnostician: person responsible for the exam.

Operator: person responsible for image collection and scanning.

Ref. Physician: person who requires the operator to carry out the ultrasound.

Tip: If the name has been entered before, it is memorized by the system and can be selected from the drop-down list.

4. Functional keys

- [Pause Exam]: pauses the current exam due to particular circumstances or system power off.
- [Cancel Exam]: cancels the current exam.

NOTE: A canceled exam cannot be restored.

- [New Patient]: clears the current patient information in the patient information screen so new patient information can be entered.
- [New Exam]: clears the current exam information so a new exam can be created for the current patient.

- [OK]: saves the patient data entered and exits the screen.
- [Cancel]: cancels the patient data entered and exits the screen.

4.1.2 Retrieve Patient Information

4.1.2.1 iStation







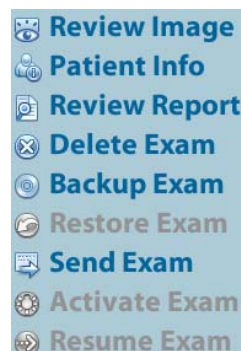

The patient data can be obtained in iStation from the system hardware or USB memory device. You can enter search conditions for the patient.

1. To enter the iStation screen (the screen is shown below):
 - Press <iStation> on the control panel, or
 - Click [iStation] in the Patient Info screen, or
 - Click [iStation] in the Review screen.



2. Select the data source
Select the data source from the “Data Source” drop-down list in the top-right corner of the screen.
3. Enter the search condition:
 - Item: including Name, ID, DOB and Exam Date. Then enter a keyword in accordance with the Item selected.
 - Select “Find in results.” The system will search on the keyword in the existing searched results.
4. Select the desired patient information in the list, and the system brings up the following menu:



Button	Function	Description
	Review an Image	Click to enter the review screen.
	Patient Information	Click to enter the patient info screen.
	Review Report	Click to enter diagnostic report screen.
	Delete Exam	Click to delete the selected record.
	Backup Exam	Click to back up the selected patient record to supported media.
	Restore Exam	Click to import the patient data from an external media.
	Send Exams	Click to send the selected patient data to an external device, DICOM storage server or printer.
	Activate Exams	Click to continue an exam that has been completed within 24 hours.
	Resume Exams	Click to continue an exam that has been paused within 24 hours.

Other buttons:

- [New Exam]: click to enter the Patient Info screen. The corresponding patient information is also imported to the new exam simultaneously. After editing the patient information in the Patient Info screen, select [OK] to start a new exam.
- [Select All Exams]: click to select all records.
- [Exit]: click to exit iStation.

4.1.2.2 Worklist

Worklist is an option. To use Worklist function, you have to configure DICOM Basic and DICOM Worklist options.

When the DICOM basic package is configured and the Worklist server has been set, click [Worklist] in the Patient Info screen to query or import the patient data. (For details about the Worklist server setting, see the DICOM chapter.)

Worklist can retrieve patient data of two kinds of protocols: DICOM and HL7.

Basic operation:

- (1) Press the <Patient> key to open the Patient Info screen.
- (2) Click [Worklist] to enter the Worklist page.

The screenshot displays the Mindray Worklist application interface. It includes a search form with fields for Patient ID, Patient Name, Accession #, Search Key (set to 'Requested Procedure ID'), Scheduled Station AE Title, Modality Type (set to 'US'), Exam Date (set to 14/03/2014), DICOM Server, HL7 Server, and Server Type (set to 'DICOM Server'). There are 'Query' and 'Clear' buttons. Below the search form, it indicates '0 records are listed.' and shows a table with columns: Patient ID, Patient Name, Accession #, Exam Description, Exam Date, Gender, and DOB. At the bottom, there are buttons for 'Start Exam', 'Transfer', 'Show Detail', and 'Exit'. A status bar at the very bottom shows '[Save] : []' and the time '17:04:40'.

- (3) Select the data source: select the server type (DICOM or HL7), choose a Worklist server in the "Worklist Server" drop-down list, and all the patient exam records are listed.
- (4) Enter the search condition:
 - Set query criteria from Patient ID, Patient Name, Accession #, Search Key, Scheduled Station AE Title, Worklist Server or Exam Date.
 - Or select the keyword type, enter the keywords, then click [Query] to search.
 - To reset the criteria, click the [Clear] button.
 - After finishing the first query, you can perform the second query based on the previous results. The scheduled patients in the list will update in real time.
- (5) Select the desired patient record in the displayed patient list:
 - a) Select the desired patient and click [Start Exam]. The patient information is imported into the system and then an exam is started.
 - b) Click [Transfer] and the patient information is imported into the [Patient Info] screen. After editing the patient information in the Patient Info screen, select [OK] to start a new exam.
- (6) Click [Exit] to exit the Worklist.

4.2 Select Exam Mode and Probe

CAUTION: If the exam mode is changed during a measurement, all measurement calipers on the image will be cleared. The general measurement data will be lost, but application measurement data will be stored in the reports.

■ Selecting exam mode

1. Connect suitable probes to the system and press <Probe> on the control panel. The screen displays the following dialog box:

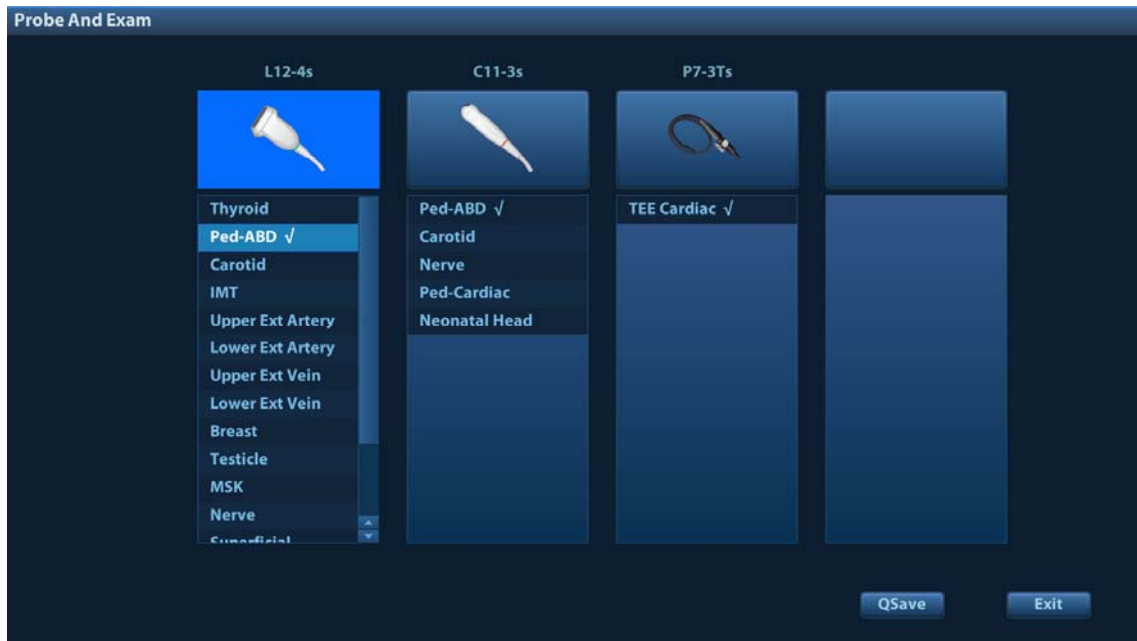

2. Use the trackball and <Set> key to select the probe type and exam mode. The system exits the dialog box and enters the selected exam mode and probe.
Click [Exit] or press <Probe> again to cancel the selection and exit the screen.

4.3 Select the Imaging Mode

For detailed operations in each imaging mode, see chapter "5 Image Optimization."

4.4 Pause & End an Exam

4.4.1 Pause an Exam

- Sometimes it is necessary to stop an uncompleted exam due to particular circumstances. When the exam is paused, the system can begin other exams.

1. Press <Patient> to enter the Patient Info screen.
2. Click [Pause Exam].

- If the system is powered off during scanning, the exam status turns to “paused” after the system restarts.

When an exam is paused, the system will:

1. Save the exam-related images, reports and measurement data, and modify the status as “Paused.”
2. Save the exam information, including imaging mode, exam mode, image parameters, operation mode, and so on.

4.4.2 End an Exam

Before examining a new patient, press <End Exam> to end the exam of the previous patient. Update the patient ID and information to avoid mixing data between patients.

To end an exam, do one of the following:

- Press <End Exam> on the control panel.
- Click [New Patient] on the Patient Info screen to end the last patient exam.
- Click [New Exam] on the Patient Info screen (or iStation or Review screen) to end the last exam.

4.5 Activate & Continue an Exam

4.5.1 Activate an Exam

On the iStation screen, select an exam record which was completed within 24 hours and click [Activate Exam] from the menu which appears. Or click [Active Exam] on the iStation or Review screen to activate the exam.

Tip:

- The system can automatically load the patient information and exam data to continue the exam.
- For an activated exam, you can modify the patient ID if the patient has no other recorded exams in the system.

4.5.2 Continue an Exam

On the iStation screen, select an exam record which was paused within 24 hours, and click [Resume Exam] from the menu which appears to continue the exam.

5 Image Optimization

⚠ WARNING:

The images displayed in this system are for reference only. Mindray is not responsible for the correctness of diagnostic results.

In Dual-B imaging mode, the measurement results of the merged image may be inaccurate. Therefore, the results are provided for reference only, not for confirming diagnoses.

Tissue Harmonic Imaging does not use contrast agents.

5.1 Imaging Mode

5.1.1 Switching Between Imaging Modes

Switch between imaging modes according to the actual situation.

Pencil probes only support CW mode.

5.1.2 Image Adjustment

- Adjust using the image menu:

For details about menu adjustment, see chapter “3.9.1 Screen Display.”

- Adjust using the soft menu (soft key)

The soft menu items displayed are corresponding to functions of soft menu controls (soft key) in the control panel.

The soft menu controls are located at the top of the control panel, as shown in the following figure.

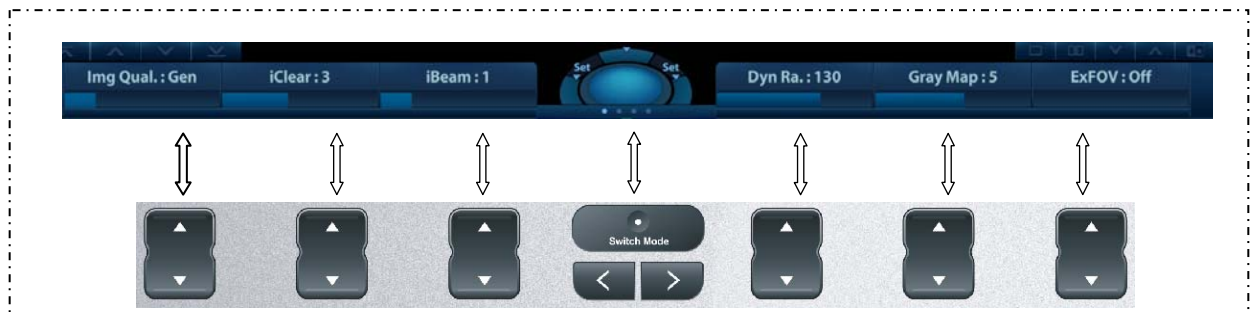

- Page-turning:
Use the left/right keys on the control panel to turn pages.
- Mode switching:



Use  to switch between the modes. The soft menu items vary depending on the mode. The menu navigation will cause the change of the menu, while the change of the menu will cause the menu navigation.

- Soft menu control (via soft key):

Soft menu items are operated respectively through the groups of soft menu controls.

- Control Panel

Adjust using the trackball, control panel key, knob or slider.

- Trackball function keys

In some modes, you need to use both the trackball and the trackball function keys to make adjustments.

For instance, in Color mode, use the trackball and the trackball function keys to adjust the ROI size/position.

For details of hint area, please refer to “3.9.1 Screen Display” chapter.

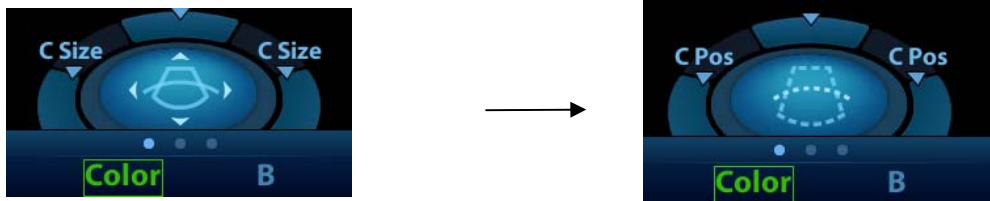

In the current status,
the trackball is used to
adjust the ROI position

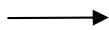

Press the left/right
<Set> key



In the current status,
the trackball is used
to adjust the ROI size.

5.1.3 Quickly Saving Image Settings

Press user-defined key for QSave to access the image data saving dialog box. (For details about user-defined key setting, please refer to “12.1.6 Key Configuration” chapter.)

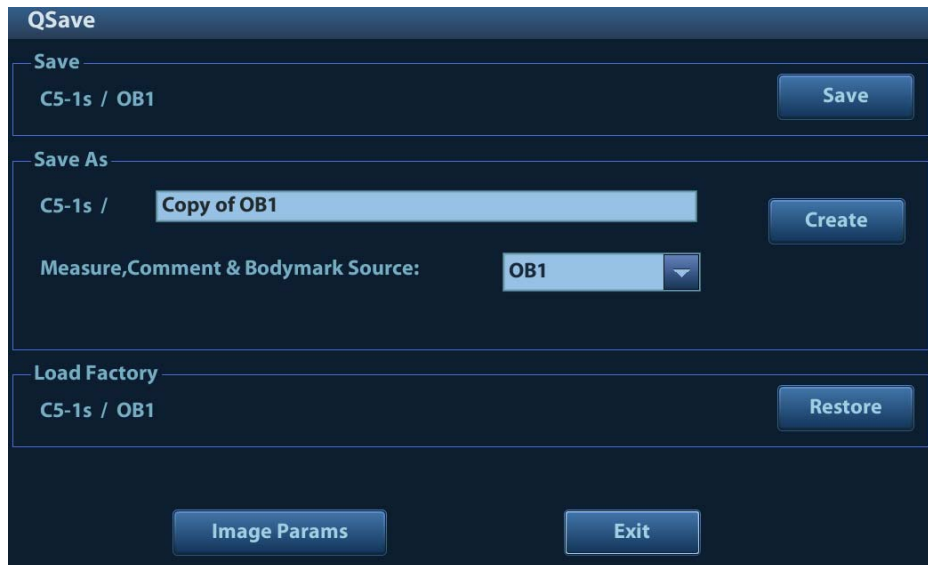

- Save the image parameter adjustment:
Click [Save] to save the current image values for the current exam mode of the particular probe.
- Create new exam data (using the current image parameter settings):
Enter the name in the box after “Save As” to assign a name for a user-defined exam mode, and click [Create] to save the current image parameters, measurements, comments and body mark settings to the exam mode.
- Restore the factory settings:
The settings of the current exam mode and the probe can be restored to factory data by clicking [Restore].
- Check image parameter level and other settings:
 - Click [Image Params] to check levels of different image parameters. Click [Save Image Parameter] to save the current image values for the current exam mode of the particular probe.
 - Select “Advanced” tab to set TIC/TIB/TIS parameter.
 - Select “Advanced” and set “Sampling Line Displaying” to “On”, then PW/M/TVM mode can be entered by pressing the imaging mode key only one time.

5.2 B Mode Image Optimization

B mode is the basic imaging mode that displays real-time images of anatomical tissues and organs.

5.2.1 Basic Procedures for B Mode Imaging

1. Enter the patient information. Select an appropriate probe and exam mode.
2. Press on the control panel to enter B mode.
3. Adjust the parameters to optimize the image.
4. Perform other operations (e.g., measurement and calculation) if necessary.
 - Press on the control panel to return to B mode at any time.

5.2.2 B Mode Parameters

In B mode scanning, the image parameter area in the top-right corner of the screen displays the real-time parameter values as follows:

Parameter	F	D	G	FR	DR	iClear	iBeam	iTouch	Zoom
Meaning	Frequency	Depth	Gain	Frame Rate	Dynamic Range	Display when the function is turned on.			

5.2.3 B Mode Image Optimization

Image Quality

- Description** To switch between the fundamental frequency and harmonic frequency, and select the corresponding frequency type. The real-time frequency value is displayed in the image parameter area in the top-right corner of the screen, and if harmonic frequency is used “F H” is displayed as the harmonic frequency value.
Select the different frequency values through [Image Quality] on the soft menu.
The adjusting range of the harmonic frequency values can be divided into 4 levels: penetration preferred (HPen), general mode (HGen), resolution preferred (HRes), and the mode between penetration preferred and general mode (HPen-Gen).
The adjusting range of fundamental frequency values can be divided into 3 levels: penetration preferred (Pen), general mode (Gen), and resolution preferred (Res).
- Impacts** The system provides an imaging mode using harmonics of echoes to optimize the image. Harmonic imaging enhances near-field resolution and reduces low-frequency and large amplitude noise, so as to improve small parts imaging.
Select the frequency according to the detection depth and current tissue features.

Gain

- Description** To adjust the gain of the whole receiving information in B mode. The real-time gain value is displayed in the image parameter area in the top-right corner of the screen.
- Operations** Rotate the <i>Touch/Gain</i> knob clockwise to increase the gain, and counter-clockwise to decrease it.
The adjusting range is 0-100 in increments of 1.
- Effects** Increasing the gain will brighten the image and you will see more received signals. However, noise may also be increased.

Depth

- Description** This function is used to adjust the sampling depth, the real-time value of which is displayed in the image parameter area in the top-right corner of the screen.
- Operations** Use the <Depth> key in the bottom-right part of the control panel to adjust the depth.
The adjustable depth values vary depending on the probe types.
- Effects** Increase the depth to see tissue in deeper locations, or decrease the depth to see tissue in shallower locations.

TGC

Description	<p>The system compensates the signals from deeper tissue by segments to optimize the image.</p> <p>There are 8-segment TGC sliders on the control panel corresponding to the areas of the image.</p>
Operations	<p>To increase the gain compensation in an area of interest, move the TGC slider to the right.</p> <p>To decrease the gain compensation in the corresponding area of interest, move the TGC slider to the left.</p> <p>About 1.5 seconds after the adjustment is complete, the TGC curve disappears.</p>
Effects	<p>Adjust the signal gain for a particular image area to achieve a balanced image.</p>

Acoustic Power

Description	<p>Refers to the power of ultrasonic waves transmitted by the probe, the real-time value of which is displayed in the upper part of the screen.</p>
Operations	<p>Adjust the acoustic power through <A.Power> on the soft menu. The system provides 100 levels for adjusting.</p>
Effects	<p>Generally, increasing the acoustic power will increase the brightness and contrast of the image and the force of penetration.</p>
Impacts	<p>You should perform exams according to actual situations and follow the ALARA Principle.</p>

Focus

Description	<p>Refers to adjusting the focus of the ultrasonic beams, using the “” symbols which are displayed to the right of the image.</p>
Operations	<p>Adjust the focus number using the [Focus Number] on the soft menu</p> <p>Use the <Focus Position> key in the bottom-right part of the control panel to adjust the focus position.</p> <p>In B mode, the available focus number can be switched between 1-4.</p>
Effects	<p>The area that is focused will be of a higher contrast and resolution.</p>
Impacts	<p>The greater the number of focal zones, the slower the frame rate.</p>

Imaging Adjustment

Description	More information can be obtained without moving the probe or changing the sampling position.
FOV (Field of View)	<ol style="list-style-type: none">1. To change the scan range, set [FOV] to "On" on the soft menu to enter the FOV range and FOV position adjustment status.2. Press <Set> to switch between FOV range and FOV position, which will change according to the hint region display.<ul style="list-style-type: none">● Roll the trackball to the left to decrease the FOV and vice versa.● Roll the trackball to the left to move the ROI to the left; roll the trackball to the right to move the ROI to the right. <p>When the scan range is adjusted to its widest, the FOV position cannot be changed.</p> <p>You can get a much larger field of view when selecting a larger FOV.</p> <p>The frame rate decreases when using a larger FOV.</p>
B Steer	Use the <Steer> keys in the bottom-left corner of the control panel to adjust the steer angle.
	During Steer adjustment, <Invert> key backlight is off and <Steer> key backlight is on.
ExFOV (Extended FOV)	Use [ExFOV] on the soft menu to turn the function on/off.
	For linear probes, the ExFOV function displays as trapezoid imaging.
	For convex probes, the ExFOV function displays as extending the scanning angle.
Impacts	The FOV position/range is available only for convex and phased probes.
	The ExFOV function is available only for convex and phased probes.
	The B Steer function is available only for linear probes.

Line Density

Description	The function determines the quality and information of the image.
Operations	Adjust the line density using the [Line Density] on the soft menu
	There are four levels of line density available: UH, M, H, L.
Effects	The higher the line density, the higher the resolution.
Impacts	The higher the line density, the lower the frame rate.

Dynamic Range

Description	This function is used to adjust the B image resolution to compress or expand the gray display range. The real-time value displays in the image parameter area in the top-right corner of the screen.
Operations	Use [Dyn Ra.] on the soft menu to adjust the dynamic range.
	The adjusting range is 30-200, in increments of 5.
Impacts	The more the dynamic range, the more specific the information and the lower the contrast with more noise.

iClear

Description	The function is used to enhance the image profile so as to distinguish the image boundary for optimization.
Operations	Adjust using the [iClear] on the soft menu The system provides 7 levels of iClear adjustment: off represents no iClear effect, and the bigger the value the stronger the effect.
Impacts	It may cause increased noise.

Persistence

Description	This function is used to superimpose and average adjacent B images, so as to optimize the image and remove noise.
Operations	Use [Persistence] on the soft menu to adjust the value. The system provides 7 levels of frame average adjustment: the bigger the value the stronger the effect.
Effects	Persistence can remove image noise to make details clearer.
Impacts	Increasing Persistence may lead to missing signals.

Rotation/Invert (U/D Flip and L/R Flip)

Description	The function provides better observation for image display.
Rotation	Rotate the image using the [Rotation] on the soft menu Images can be rotated by 0°, 90°, 180° and 270°. When the image is rotated by 90° or 270°, the depth scale is displayed in the top part of the screen.
Invert (U/D Flip and L/R Flip)	To invert the image horizontally or vertically. Click [U/D Flip] or [L/R Flip] on the soft menu to invert the image
Effects	You can identify the image orientation using the “M9” mark on the screen. By default, the “M9” mark is located in the top-left corner of the imaging area.

iBeam (Spatial Compound Imaging)

Description	This function is used to superimpose and average images of different steer angles to achieve image optimization.
Operations	Adjust using the [iBeam] on the soft menu The system provides different levels of iBeam adjustment in single B mode. Off represents no iBeam.
Effects	Images can be optimized with less spot noise and higher resolution, so that more details for the structure are revealed.
Impacts	The adjustable iBeam levels vary depending on the probe types. iBeam is valid for linear and convex probes, and it is not available when the ExFOV function is turned on.

Image Merge

- Description** In the Dual-split mode, when the images of the two windows have the same probe type, depth, invert status, rotation status and magnification factor, the system will merge the two images so as to extend the field of vision.
- Operations** Turn the function on or off using the [Auto Merge] on the soft menu
- Impacts** The function is valid only for linear probes.

Gray Map

- Description** This function applies the gray correction to obtain optimum images.
- Operations** Select from among the maps by using [Gray Map] on the soft menu. The system provides 8 different gray effect maps.

Tint Map

- Description** This function provides an imaging process based on color difference rather than gray distinction.
- Operations** Use [Tint Map] on the soft menu to select the map. The system provides 8 different color effect maps.
Use [Tint Map] on the soft menu to turn the function on/off.

TSI (Tissue Specific Imaging)

- Description** The TSI function is used to optimize the image by selecting acoustic speed according to tissue characteristics.
- Operations** Select from among the TSI modes using the [TSI] on the soft menu
The system provides four ways of optimizing for specific tissues: general, muscle, fluid and fat.

iTouch (Auto Image Optimization)

- Description** To optimize image parameters as per the current tissue characteristics for a better image effect.
- Operations** Press <iTouch> on the control panel to turn the function on.
The iTouch symbol will be displayed in the image parameter area in the top-right corner of the screen once <iTouch> is pressed.
Select different levels of iTouch effect using [iTouch] on the soft menu.
Long press the <iTouch> key to exit the function.

H Scale

- Description** Display or hide the width scale (horizontal scale).
The scale of the horizontal scale is the same as that of the vertical scale (depth). They change together in zoom mode, or when the number of the image window changes. When the image is turned up/down, the H Scale will also be inverted.
- Operations** Click [H Scale] on the soft menu to display or hide the scale.

Dual Live

- Description** Display different image effects of one probe for better observation.
- Operation** Click [Dual Live] on the soft menu to turn the function on/off. Dual-split windows of the images are displayed on the main screen.
- Two pages of adjustable parameters are displayed in the soft menu. Shared parameters and left window parameters are displayed in the B(L) page, while right window parameters are displayed in the B(R) page.
- Use mode switching key (<Switch Mode>) to switch windows for image parameter adjustment.
- In the image parameter area in the top-right corner of the main screen, parameters of both windows are displayed.
- Impacts** Image magnification is available in dual live mode.

LGC

- Description** Adjust the gain of scan lines to increase the image lateral resolution.
- Operation** Select [LGC] on the soft menu to access the adjusting dialog box.
- The 4 rods displayed on the screen indicate the corresponding image areas on the image screen.
- Click corresponding [LGC1-4] to adjust the gain, the higher the value, the higher the gain.
- The system also provides several preset parameters for imaging.

Echo Boost

- Description** This function can improve contrast and decrease noise, so that a much clearer boundary can be seen.
- Operation** Set [Echo Boost] "On" on the soft menu to turn the function on (when the function is turned on, the system indicates "Echo Boost" in the image parameter area).
- Impacts** This function is only available using the phased probe in cardiac exam mode (the P7-3Ts probe does not support this function)

Patient Temperature

- Description** If the current active probe is P7-3Ts, the parameter will display under the B mode menu. You can enter the patient temperature by this function.
- Operation** Enter the temperature by [Patient Temperature] on the soft menu.



WARNING:

If the patient temperature is above 37° C (98.6° F) and the [Patient Temperature] setting is below the actual reading, the system could overestimate the temperature of TEE transducer's distal tip. This could trigger the Auto-Cool feature. If the patient temperature reaches or is near 37° C (98.6° F) and the [Patient Temperature] setting is above the actual reading, the system could underestimate the temperature of the TEE transducer's distal tip. The patient is exposed to excessive temperatures.

5.3 M Mode Image Optimization

5.3.1 Basic Procedures for M Mode Imaging

1. Select a high-quality image during B mode scanning, and adjust to position the area of interest in the center of the B mode image.
2. Press <M> on the control panel, and roll the trackball to adjust the sampling line.
3. Press <M> on the control panel again or <Update> to enter M mode. You can then observe the tissue motion along with the anatomical images of B mode. During the scanning process, you can also adjust the sampling line accordingly when necessary.
4. Adjust the image parameters to obtain optimized images.
5. Perform other operations (e.g., measurement and calculation) if necessary.

If “Sampling Line Displaying” is selected, then the screen will display the sampling line all the time and pressing <M> one will lead to entering M mode directly. See “5.1.3 Quickly Saving Image Settings” chapter for details.

5.3.2 M Mode Image Parameters

- In M mode scanning, the image parameter area in the top-right corner of the screen displays the real-time parameter values as follows:

Parameter	F	D	G	V	DR
Meaning	Frequency	Depth	M Gain	M Speed	M Dynamic Range

- During M mode imaging, menus for B mode and M mode are displayed on the screen at the same time. You can switch between the 2 modes by pressing the <Switch Mode> key.
- During M mode scanning, depth, focus position, frequency and acoustic power of the probe are synchronous with that of B mode.
- Adjustment of the TGC to the B mode image will lead to synchronous changes in the M mode image.

5.3.3 M Mode Image Optimization

Gain

- Description** To adjust the gain of M mode image. The real-time gain value is displayed in the image parameter area in the top-right corner of the screen.
- Operations** Rotate the <i>Touch/Gain</i> knob clockwise to increase the gain, and counter-clockwise to decrease it.
The adjusting range is 0-100 in increments of 1.
- Effects** Increasing the gain will brighten the image and you will see more received signals. However, noise may also be increased.

Display Format

- Description** To set the display format of M mode images and B mode images.
- Operations** Select [Display Format] on the soft menu to adjust.
There are 5 formats available for image display: H2:3, V2:3, V3:2, V3:1, Full.
- Effects** Select different format types according to the actual situation and obtain a desired analysis through comparison.

Speed

- Description** This function is used to set the scanning speed of M mode imaging, and the real-time speed value is displayed in the image parameter area in the top-right corner of the screen.
- Operations** Use [Speed] on the soft menu to adjust.
There are 6 levels of scan speed available: the corresponding values are displayed on the soft menu in real time.
- Effects** Changing speed makes it easier to identify disorders in cardiac cycles.

Tint Map

- Description** This function provides an imaging process based on color difference rather than gray distinction.
- Operations** Use [Tint Map] on the soft menu to select the map. The system provides 8 different color effect maps.
Use [Tint Map] on the soft menu to turn the function on/off.

Gray Map

- Description** This function applies the gray correction to obtain optimum images.
- Operations** To select from among the maps, use [Gray Map] on the soft menu. The system provides 8 different gray effect maps.

Edge Enhance

- Description** This function is used to enhance the image profile so as to distinguish the image boundary for optimization.
- Operations** Adjust using the [Edge Enhance] on the soft menu
There are 3 levels of edge enhance adjustment available: the bigger the value the stronger the effect.
- Impacts** Larger edge enhance may lead to increased noise.

Dynamic Range

- Description** This function is used to adjust the M image resolution to compress or expand the gray display range.
The real-time dynamic range value is displayed in the image parameter area in the top-right corner of the screen.
- Operations** Use the [Dyn Ra.] on the soft menu to adjust.
The adjusting range is 30-180dB, in increments of 5dB.
- Effects** The more the dynamic range, the more specified the information.

M Soften

- Description** This feature is used to process the scan lines of M images to reject noise, making image details clearer.
- Operations** Use the [M Soften] on the soft menu to adjust.
The system provides 4 levels of M Soften adjustment: the bigger the value the stronger the effect.

5.4 Color Mode Image Optimization

The Color mode is used to detect color flow information, and the color is designed to judge the direction and speed of blood flow.

Generally, the color above the color bar indicates the flow towards the probe, while the color below the color bar indicates the flow away from the probe. The brighter the color, the faster the flow speed, while the darker the color, the slower the flow speed.

5.4.1 Basic Procedures for Color Mode Imaging

1. Select a high-quality image during B mode scanning, and adjust to position the area of interest in the center of the B mode image.
2. Press <C> to enter B + Color mode. Roll the trackball to change the position and size of the Region of Interest (ROI) and press the <Set> key to set.
3. Adjust the image parameters during scanning to obtain optimized images.
4. Perform other operations (e.g., measurement and calculation) if necessary.

5.4.2 Color Mode Image Parameters

- In Color mode scanning, the image parameter area in the top-right corner of the screen displays the real-time parameter values as follows:

Parameter	F	G	PRF	WF
Meaning	Frequency	Color Gain	Pulse Repetition Frequency (PRF)	Color Wall Filter

- During Color mode imaging, the image optimizing menus for B mode and Color mode are displayed on the soft menu at the same time. You can switch between the 2 modes by pressing the <Switch Mode> key.
- In Color mode, the acoustic power is synchronous with that of B mode. Adjustment of the depth to the B mode image will lead to corresponding changes in Color mode image.

5.4.3 Color Mode Image Optimization

Color Gain

- Description** Refers to the overall sensitivity to flow signals. This function is used to adjust the gain in Color mode. The real-time gain value is displayed in the image parameter area in the top-right corner of the screen.
- Operations** Rotate the <i>Touch/Gain</i> knob clockwise to increase the gain, and counter-clockwise to decrease it.
The adjusting range is 0-100 in increments of 2.
- Effects** Increasing the gain will increase the flow signal presented and noise. The signals may be missing when the gain is adjusted too low.

ROI Adjustment

- Description** This function adjusts the width and position of the ROI in Color mode.
- Operations** When the ROI box is a dotted line, roll the trackball to change the size.
When the ROI box is a solid line, roll the trackball to change the position.
Press <Set> to switch between the solid line and the dotted line.
- Impacts** The larger the ROI box, the lower the frame rate, and the lower the resolution and color sensitivity.

Image Quality

- Description** Refers to the operating frequency of the probe in Color mode, the real-time value of which is displayed in the image parameter area in the top-right corner of the screen.
- Operations** Use [Image Quality] on the soft menu to select the different frequency values.
The adjusting range of frequency values can be divided into 3 levels: penetration preferred (Pen), general mode (Gen), and resolution preferred (Res).
Frequency values vary according to probe types. Select the frequency according to the needs of the detection depth and the current tissue characteristics.

B/C Align

- Description** To set and restrict the maximum width of the B mode image to that of the Color ROI.
- Operations** Turn the function on or off using the [B/C Align] on the soft menu
- Impacts** The frame rate increases when the function is turned on.

Dual Live

- Description** This function is used to display the B image and Color image synchronously.
- Operations** Turn the function on or off using the [Dual Live] on the soft menu.
When the function is turned on, the window will automatically switch to dual windows (one for the B image, and the other for the Color image).

Steer

- Description** The feature is used to adjust the ROI of the color flow of different angles with immobility of the linear probe.
- Operations** Adjust using the <Steer> keys on the control panel.
During Steer adjustment, <Invert> key backlight is off and <Steer> key backlight is on.
- Effects** This function is used to adjust the scan angle of linear probes, so as to change the angle between the transmitting beam and flow direction.
- Impacts** Steer is only valid for linear probes.

Line Density

- Description** Line density determines the quality and information of the image.
- Operations** Adjust using the [Line Density] on the soft menu
4 levels of line density are provided: H, L, UH, M.
- Effects** The higher the line density, the higher the resolution.
- Impacts** The higher the line density, the lower the frame rate.

Packet Size

- Description** This function is an indication of the ability to detect flow, which is used to adjust the accuracy of color flow.
- Operations** Use [Packet Size] on the soft menu to adjust the value.
There are 3 levels of packet size available: 0 represents no packet size control and the bigger the value the higher the sensitivity.
- Effects** The higher the packet size, the more sensitive the indication for low-velocity flow.
- Impacts** Adjusting the packet size may lead to the frame rate changing.

Flow State

- Description** This function is used for fast image optimization.
- Operations** Adjust using [Flow State] on the soft menu.
3 levels are provided: L, M, H.

Persistence

- Description** This function adjusts the temporal smoothing in Color mode to optimize the image.
- Operations** Use [Persistence] on the soft menu.
The system provides 6 levels of persistence adjustment: 0 represents no persistence, and the bigger the value the stronger the effect.

Smooth

- Description** This feature is used to reject noise and smooth the image.
- Operations** Adjust using the [Smooth] on the soft menu.
The system provides 6 levels of smooth function: the bigger the value the stronger the effect.

Scale

- Description** This function is used to adjust the speed range of the color flow, which is adjusted using the PRF in the system. The real-time PRF value is displayed in the image parameter area in the top-right corner of the screen.
- Operations** Use the <Scale> keys on the control panel to adjust it.
The adjusting range varies according to the frequency, probe and depth. Adjust according to the actual situation.
- Effects** Provides a much clearer color flow image.
Use a low PRF to observe low-velocity flows, and a high PRF to observe high-velocity flows.
- Impacts** Aliasing may occur if a low-velocity scale is used and high velocities are encountered.
Low velocities may not be identified when a high-velocity scale is used.

Baseline

- Description** Refers to the area where the velocity is zero in the scale. Adjust according to the actual situation so as to get an optimum flow display.
- Operations** Use the <Baseline> keys in the bottom-left part of the control panel to adjust it.
A positive value means increase the signals above the baseline, and a negative value means increase the signals below the baseline.

Invert

- Description** To set the display mode of the color flow. The color scale will be inverted when the function is turned on.
- Operations** Turn the function on or off using the [Invert] on the soft menu.
If current probe is a linear probe, you can also switch the invert function by pressing <Invert> keys in the bottom-left part of the control panel.
Select "Auto Invert" in "[Setup] → [System Preset] → [Image]", so the color bar can automatically invert when the color flow is steered to a certain angle to accommodate the operator's desire to distinguish the flow direction.
- Impacts** Auto invert function is available only for linear probes.

Color Map

- Description** This function is a combination of several image parameters, which indicates the display effect of the color image.
- Operations** Use [Color Map] on the soft menu to select from among the maps.
The system provides 21 different maps for selection. The V group provides 11 ordinary maps and the VV group provides 10 2D maps.

WF (Wall Filter)

- Description** It filters out low-velocity signals to provide effective information, and this function is used to adjust the filtered frequency. The real-time value is displayed in the image parameter area in the top-right corner of the screen.
- Operations** Select using the [WF] on the soft menu
There are 8 levels of wall filter function available. Select the value according to the actual situation.
- Impacts** Flow signals may be missing.

Priority

- Description** This function is used to set the levels of the flow display and to display the grayscale signal or color signal.
- Operations** Use [Priority] on the soft menu to select the value.
The adjusting range of the priority is 0-100% in increments of 1%.
The higher the value, color signals are first to be displayed. The lower the value, grayscale signals are first to be displayed.

Velocity tag

- Description** This function is used to mark the specified velocity range in the flow to check the flow function or specific flow velocity value.
- Operation**
1. Click [Velocity Tag] on the soft menu to enter the velocity marking status. A green mark appears on the color bar.
 2. Roll the trackball upwards and downwards to select the marking velocity.
 3. Press <Set> to enter the tag range selection status, and roll the trackball upwards and downwards to select the range.
 4. Press <Set> to enter ROI position selecting status. Roll the trackball to position the ROI.
 5. Press <Set> to enter ROI size selecting status. Roll the trackball to adjust the ROI size.
Press <Set> to switch between marking position and marking range.

iTouch (Auto Image Optimization)

- Description** To optimize image parameters as per the current tissue characteristics for a better image effect.
- Operations** Press <iTouch> on the control panel to optimize the image once.

HR Flow (High Resolution Flow)

- Description** This function enhances the micro vessel imaging effect, and can be used to analyze the tissue blood supply condition.
- Operations** Set [HR Flow] on the menu in the top-left corner of the screen to "On" to turn on HR Flow status.
The parameters in HR Flow mode are independent from those in Color mode.

5.5 Power Mode Image Optimization

Power mode provides a non-directional display of the blood flow in terms of intensity as opposed to flow velocity.

DirPower (Directional Power mode) provides additional information of the flow direction toward or away from the probe.

5.5.1 Basic Procedures for Power Mode Imaging

1. Select a high-quality image during B mode or B + Color scanning, and adjust to position the area of interest in the center of the image.
2. Press <P> to enter B + Power mode. Roll the trackball to change the position of the Region of Interest (ROI) and press the <Set> key to set. Roll the trackball to change the size and position of the ROI.
3. Adjust the image parameters during B + Power mode scanning to obtain optimized images.
4. Perform other operations (e.g., measurement and calculation) if necessary.

5.5.2 Power Mode Image Parameters

- In Power mode scanning, the image parameter area in the top-right corner of the screen displays the real-time parameter values as follows:

Parameter	F	G	PRF	WF
Meaning	Frequency	Power Gain	Pulse Repetition Frequency (PRF)	Power Wall Filter

- During Power mode imaging, the image optimizing menus for B mode and Power mode are displayed on the soft menu at the same time. You can switch between the 2 modes by pressing the <Switch Mode> key.
- In Power mode, the acoustic power is synchronous with that of B mode. Adjustment of the depth to the B mode image will lead to corresponding changes in Power mode image.

Parameters consistent with those in Color mode and B mode are not described. See the relevant Color mode and B mode sections, while special items of the Power mode are introduced in the following.

5.5.3 Power Mode Image Optimization

Power Gain

- Description** Refers to the overall sensitivity to flow signals. This function is used to adjust the gain in Power mode.
The real-time gain value is displayed in the image parameter area in the top-right corner of the screen.
- Operations** Rotate the <iTouch/Gain> knob clockwise to increase the gain, and counter-clockwise to decrease it.
The adjusting range is 0-100 in increments of 2.
- Effects** Increasing the gain will increase the flow signal presented and noise. The signals may be missing when the gain is adjusted too low.

Map

- Description** This feature indicates the display effect of the Power image.
The maps in the Power mode image are grouped into two categories: Power maps and Directional Power maps.
- Operations** To select from among the maps, select [Power Map] on the soft menu.
There are 8 kinds of maps provided: P0-3 belong to Power mode maps, while Dp0-3 belong to Directional Power mode maps.
The Power maps provide information about blood flow, which are highly sensitive to the low-velocity flows.
The Directional Power maps provide information about flow direction.

Dynamic Range

- Description** This function adjusts the transformation of echo intensity into color signal.
- Operations** Use [Dyn Ra.] on the soft menu to adjust the dynamic range.
The adjusting range is 10-70dB in increments of 5dB.
- Effects** Increasing the dynamic range leads to higher sensitivity to low-power signals, thus enhancing the range of signals to display.

5.6 PW/CW Doppler Mode

PW (Pulsed Wave Doppler) mode or CW (Continuous Wave Doppler) mode is used to provide blood flow velocity and direction utilizing a real-time spectrum display. The horizontal axis represents time, while the vertical axis represents Doppler frequency shift.

PW mode provides a function for examining flow at one specific site for its velocity, direction and features. CW mode proves to be much more sensitive to high-velocity flow display. Thus, a combination of both modes will contribute to a much more accurate analysis.

CW imaging is an option.

Adjustment items, such as SV, Steer, Duplex, Triplex, iTouch and HPRF, are not available in CW mode.

5.6.1 Basic Procedures for PW/CW Mode Exam

1. Select a high-quality image during B mode or B + Color (Power) mode scanning, and adjust to position the area of interest in the center of the image.
2. Press <PW>/<CW> to adjust the sampling line,
 - The sampling status will be displayed in the image parameter area in the top-right corner of the screen as follows:

PW Sampling Line Adjustment	SV
	Angle
	SVD
CW Sampling Line Adjustment	Angle
	CW Focus Depth

3. Set the position of the sample line by moving the trackball left and right. Set the SVD by moving the trackball up and down. Adjust the angle and SV size according to the actual situation.
4. Press <PW>/<CW> or <Update> again to enter PW/CW mode and perform the examination. You can also adjust the SV size, angle and depth in real-time scanning.
5. Adjust the image parameters during PW/CW mode scanning to obtain optimized images.
6. Perform other operations (e.g., measurement and calculation) if necessary.

If “sampling line displaying” is selected, then the screen will display the sampling line all the time and pressing <M> one will lead to entering M mode directly. For details, see “5.1.3 Quickly Saving Image Settings” chapter.

5.6.2 PW/CW Mode Image Parameters

In PW/CW mode scanning, the image parameter area in the top-right corner of the screen displays the real-time parameter values as follows:

PW	Parameter	F	G	PRF	WF	SVD	SV	Angle
	Meaning	Frequency	Gain	PRF	Wall Filter	SV Position	SV Size	Angle
CW	Parameter	F	G	PRF	WF	SVD		Angle
	Meaning	Frequency	Gain	PRF	Wall Filter	SV Position		Angle

- During PW/CW mode imaging, the image optimizing menus for B mode and PW/CW mode are displayed on the soft menu at the same time. If Color mode (Power mode) is also working, menus for certain modes will be displayed on the screen synchronously, and you can switch between them by pressing the <Switch Mode> key.
- When you adjust the depth of the B mode image, related changes will occur in the PW/CW mode image as well.
- Most of the parameters are the same for the PW mode and CW modes, so parameters of both are combined together to be introduced here.

Only phased probes support CW mode.

5.6.3 PW/CW Mode Image Optimization

Gain

- Description** This function is intended to adjust the gain of the spectrum map. The real-time gain value is displayed in the image parameter area in the top-right corner of the screen.
- Operations** Rotate the <i>Touch/Gain</i> knob clockwise to increase the gain, and counter-clockwise to decrease it.
The adjusting range is 0-100 in increments of 2.
- Effects** Increasing the gain will brighten the image and you will see more received signals. However, noise may also be increased.

SV

- Description** To adjust the SV position and size of sampling in PW mode, the real-time value of SV and SVD are displayed in the image parameter area in the top-right corner of the screen.
- SV size** Use [SV] on the soft menu to adjust the SV size.
Value: 0.5-20 mm.
- SVD** Roll the trackball to select the SV depth.
- Effects** The smaller the SV size, the more accurate the result. More details are obtained when selecting a large SV size.

CW Focus Position

- Description** To adjust the CW mode SVD. The real-time focus position value is displayed in the image parameter area in the top-right corner of the screen.
- Operation** Roll the trackball to select the focus depth.

Image Quality

- Description** Refers to the operating frequency of the probe in PW mode, the real-time value of which is displayed in the image parameter area in the top-left corner of the screen.
- Operation** Use [Image Quality] on the soft menu to select the different frequency values.
The adjusting range of frequency values can be divided into 3 levels: penetration preferred (Pen), general mode (Gen), and resolution preferred (Res).
Select the frequency according to the detection depth and current tissue features.
- Effects** The higher the frequency, the better the resolution and sensitivity, and the worse the force of penetration.

Scale

Description	This function is used to adjust the speed range of the flow, which is adjusted using the PRF in the system. The real-time PRF value is displayed in the image parameter area in the top-right corner of the screen.
Operations	Use <Scale> keys on the control panel.
Effects	Provides a much clearer color flow image. Use a low PRF to observe low-velocity flows, and a high PRF to observe high-velocity flows.
Impacts	Aliasing may occur if a low-velocity scale is used and high velocities are encountered. Low velocities may not be identified when a high-velocity scale is used.

iTouch

Description	To optimize image parameters as per the current tissue characteristics for a better image effect.
Operations	Press <iTouch> on the control panel to optimize the image once.

Auto-Calculation

Description	This function is used to trace the spectrum and calculate the PW/CW mode image parameters. The results are displayed in the results window. <ol style="list-style-type: none">1. Click [Auto Calc] on the soft menu to turn the auto calculation function on or off.2. After the auto calculation function is turned on, switch to "Auto Calculation" menu by pressing the <Switch Mode> key.
Auto Calculation Parameter	Select parameters in the dialog box prompted by clicking [Auto Calc. Param.] on the soft menu.
Auto Calculation Cycle	To set the heart cycle number for auto-calculation. Click [Auto Calc Cycle] on the soft menu to select the cycle number.
Trace Area	To set the trace area of the Doppler wave in the spectrum map, applicable for auto calculation, V Max and V Mean display. To change the trace area, click [Trace Area] on the soft menu. The available selections of trace area are: Above, Below, All.
Trace	To set the smooth level when tracing.
Smooth	To change the trace area, click [Trace Smooth] on the soft menu. There are 4 levels of smooth effect provided, the bigger the value, the higher the smooth processing.
Trace	This function is used to set the sensitivity of tracing in the spectrum.
Sensitivity	To change the trace area, click [Trace Sensitivity] on the soft menu. There are 5 levels of sensitivity adjustment, the bigger the value the higher the sensitivity.

Operations In real-time scanning, the results displayed are derived from the calculation of the latest cardiac cycle.
In the freeze and cine status, the results displayed are calculated from the current selected area.

Invert

Description This function is used to set how the spectrum is displayed.

Operations Turn the function on or off using the [Invert] on the soft menu.
If current probe is a linear probe, you can also switch the invert function by pressing <Invert> keys in the bottom-left part of the control panel.
Select “Auto Invert” in the “[Setup]→ [System Preset] → [Image]”, so the spectrum can automatically invert when the color flow is steered to a certain angle to accommodate the operator’s desire to distinguish the flow direction.

Speed

Description This function is used to set the scanning speed of PW mode imaging.

Operations Use [Speed] on the soft menu.
There are 6 levels of scan speed available: the corresponding values are displayed on the soft menu in real time.

Effects Changing the speed makes it easier to identify the cardiac cycles and to detect more details.

T/F Res.

Description This function is used to create a balance between time resolution and spatial resolution.

Operations Adjust using the [T/F Res.] on the soft menu.
There are 4 levels of T/F Res. values available.

Wall Filter

Description It filters out low-velocity signals to provide effective information, and this function is used to adjust the filtered frequency. The real-time value is displayed in the image parameter area in the top-right corner of the screen.

Operations Select using the [WF] on the soft menu
7 levels of wall filter function are provided.

Impacts Signals of low-velocity flow may be missing.

Tint Map

Description This function provides an imaging process based on color difference rather than gray distinction.

Operations Use [Tint Map] on the soft menu to select the map. There are 8 color effect maps available.
Use [Tint Map] on the soft menu to turn the function on/off.

Gray Map

- Description** This function applies the gray correction to obtain optimum images.
- Operations** To select from among the maps, use [Gray Map] on the soft menu. There are 10 gray effect maps available.

Display Format

- Description** To set the display format of PW mode images with B mode images.
- Operations** Use [Display Format] on the soft menu to select.
There are 5 formats for displaying the images: H2:3, V2:3, V3:2, V3:1, Full.

Duplex/Triplex

- Description** This function is used to set whether a B image (B + Color image) and PW image are displayed synchronously.
- Operations** Click [Duplex]/[Triplex] on the soft menu to turn the synchronization on or off.

HPRF

- Description** HPRF mode is used when detected velocities exceed the processing capabilities of the currently selected PW Doppler scale, or when the selected anatomical site is too deep for the selected PW Doppler scale.
- Operations** Turn the function on or off using the [HPRF] on the soft menu.
- Effects** HPRF enhances the range for detecting high-velocity flow.

Baseline

- Description** Refers to the area where the velocity is zero in the spectrum.
- Operations** Adjust using the <Baseline> keys in the lower left corner of the control panel.
- Effects** Changes the flow-velocity range to optimize the image.

Angle

- Description** This function is used to adjust the angle between Doppler vector and flow to make the velocity more accurate.
The real-time adjusting angle value is displayed on the right part of the spectrum map.
- Operations** Rotate the <Angle> knob on the control panel to adjust it.
The adjustable angle range is -89~89°, in increments of 1°.

Quick Angle

- Description** To adjust the angle faster, in increments of 60°. The real-time value is displayed on the right part of the spectrum map.
- Operations** Adjust using the [Quick Angle] on the soft menu
There are 3 angles for quick adjustment: -60°, 0° and 60°.

Dynamic Range

- Description** The dynamic range conveys the information which is being transformed from echo intensity to grayscale.
- Operations** Adjust using the [Dyn. Ra.] on the soft menu
The adjusting range is 24-72dB.
- Effects** The more the dynamic range, the more specific the information and the lower the contrast with more noise.

Audio

- Description** This function is used to adjust the output audio in the spectrum map.
- Operations** Use the <Volume> on the soft menu to adjust the volume.
The adjusting range of the audio is 0-100%.
- Effects** Utilizing the output audio helps to identify the feature and the status of flow.

PW Steer

- Description** This function is used to adjust the angles for the sampling line.
- Operations** Adjust using the <Steer> keys in the bottom-left corner of the control panel.
- Effects** This feature is used to steer the direction of the beam so as to change the angle between the beam and flow direction with immobility of the linear probe.
The values of steer angles vary according to the probe.
- Impacts** The PW Steer function is available only for linear probes.

5.7 Color M Mode

Color M mode provides information about color flow or tissue on the M mode images to indicate the cardiac motion state. It is highly sensitive to the flow or tissue movement.

The Color M mode includes Color Flow M mode and Color Tissue M mode.

Color M mode is not available by linear probes.

5.7.1 Enter Color M Mode

- Color Flow M Mode
 - In B + M mode, press <C> on the control panel to enter the sampling line adjustment status, and press <M> again.
 - In B + Color, B + Color + PW or B + Color + CW mode, press <M> twice on the control panel.
- Color Tissue M Mode (TVM)
 - In B + TVI/TVD, or B + TVI + TVD mode, press <M> twice on the control panel.
 - In Color Flow M mode, press <TDI> on the control panel to enter the sampling line adjustment status, and press <M> again.

5.7.2 Exit Color M Mode

- Press <C> or <M> on the control panel to exit Color M mode.
- Or, press on the control panel to return to B mode.

5.7.3 Color M Mode Image Parameters

- In Color Flow M mode, the parameters that can be adjusted are the same as those in B, M and Color modes. See the relevant B, Color and M mode sections for details.
- In Color Tissue M mode, the parameters that can be adjusted are the same as those in B, M and TVI modes. See the relevant B, M and TVI mode sections for details.
- In Color M mode scanning, the image parameter area in the top-right corner of the screen displays the real-time parameter values.
- ROI Adjustment

The ROI determines the size and position of the color flow or color tissue displayed in the Color M mode image.

- Set the position of the sampling line by moving the trackball left and right, and set the ROI position by moving the trackball.
- Set the ROI size by moving the trackball.
- Press <Set> to switch the cursor status between ROI position adjustment, ROI size and M sampling line adjustment.
- Press <Update> on the control panel to switch between the real-time mode and freeze mode.

5.8 Anatomical M Mode



CAUTION:

Anatomical M Mode and Color Anatomical M mode images are provided for reference only, not for confirming diagnoses. Compare the image with those of other machines, or make diagnoses using non-ultrasound methods.

For an image in the traditional M mode, the M-mark line goes along the beams transmitted from the probe. Thus it is difficult to obtain a good plane for difficult-to-image patients who cannot be moved easily. However, in the Anatomical M mode, you can manipulate the M-mark line and move it to any position at desired angles. The system supports anatomical M scanning (including Free Xros M mode and Free Xros CM mode) in 2D imaging modes (B, Color, Power and TVI mode).

Free Xros M imaging and Free Xros CM imaging are options.

5.8.1 Free Xros M Imaging (Anatomical M-Mode)

5.8.1.1 Basic Procedures for Free Xros M Imaging

1. In real-time B mode or M mode, adjust the probe and image to obtain the desired plane.
Or select the desired 2D cine files.
2. Click [Free Xros M] on the menu in the top-left corner of the screen to enter Free Xros M mode, or press the user-defined key.
3. Adjust the M-mark (single or multiple) line to obtain optimized images and necessary information.

Free Xros M imaging is supported on frozen B images, B+M images and B+Power/Color/TVI images.

5.8.1.2 Free Xros M Image Parameters

- During Free Xros M mode imaging, the image optimizing menus for B mode and Free Xros M mode are displayed on the soft menu at the same time. You can switch between the 2 modes by pressing the <Switch Mode> key.
- Parameters consistent with those in M mode are not to be introduced. See the relevant M mode section, while Free Xros M mode special items will be introduced in the following.

Display/Hide the M-mark Line

Description	There are 3 M-mark lines available, each with "A", "B" or "C" at the one end as identification and an arrow at the other end to mark the direction.
M-mark Line Selection	Perform the selection using the [Show A], [Show B] or [Show C] on the soft menu, and the corresponding image will be displayed on the screen once the related item is selected.
Display current	Select [Display Cur.] or [Display All] on the soft menu to select whether to display the image of the current M-mark line or all.
Impacts	When there is only one M-mark line on the screen, it cannot be hidden.

Switching between the M-mark Lines

Description	To switch between the M-mark lines in Free Xros M mode.
Operations	Press <Set> to switch between the M-mark lines and press <Cursor> to show the cursor. The activated M-mark line will be green and the inactivated one will be white.

Adjusting the M-mark Line

Description	To adjust the position and angle of the M-mark line.
Operations	<ul style="list-style-type: none">● Position Adjustment When the M-mark line is activated, move the trackball left and right to adjust the position. The direction is recognized by the arrow at the end of the line.● Angle Adjustment When the M-mark line is activated, move the trackball to adjust the fulcrum of the line, and adjust using the [Angle] deflector rod on the control panel. The adjusting angle range is 0-360°, in increments of 1°.

5.8.1.3 Exit Free Xros M

In Free Xros M mode, press B or the user-defined Free Xros M key to exit Free Xros M mode.

5.8.2 Free Xros CM (Curved Anatomical M-Mode)



CAUTION:

Free Xros CM images are provided for reference only, not for confirming diagnoses. Compare the image with those of other machines, or make diagnoses using non-ultrasound methods.

In Free Xros CM mode, the distance/time curve is generated from the sample line manually depicted anywhere on the image. Free Xros CM mode can be entered using TVI or TEI modes.

Only the phased probe supports Free Xros CM

5.8.2.1 Basic Procedures for Free Xros CM

1. In B real-time imaging mode, adjust the probe and image to get the desired image, then fix the probe.
2. Press <TDI> to enter TDI imaging and acquire the necessary images.
3. Press <Cursor> to show the cursor, click [Free Xros CM] on the menu in the top-left corner of the screen to enter Free Xros CM mode.
4. Press the user-defined key for Free Xros CM to enter Free Xros CM mode.
5. Roll the trackball to define the start point of the sample line on the B image.
The cursor displays as , and can only be moved within the B image.
6. Press <Set> to fix the start point. The digital number “1” is marked beside the point.
7. Define the next point using the trackball and <Set> key (click [Undo] to cancel the current point and activate the preview point). The system updates the time-motion curve in real time. The sample line is displayed in green, and each point is marked with a number in sequence.
8. Repeat Step 6 to finish the sample line.
9. Double-click the <Set> key to end editing. The sample line is displayed in white.
10. Adjust the image parameters to optimize the image, obtain the relevant tissue image for data analysis, then save the image if necessary.
11. Press the again to exit Free Xros CM mode.

Sample Line Modification

1. To enter curve (sample line) modification status:
 - For a completed sample line, set [Edit] to “On” and the sample line is editable.
2. Anchor the cursor to a certain point, press the <Set> key to activate the point, then roll the trackball to drag the point for a desired sample line.
3. Double-click the <Set> key to end editing. The sample line is displayed in white.

Delete a Sample Line

Click the sample line to select it, and click [Delete] to delete the selected line. You can re-create a new sample line.

Tip:

The free Xros M mode and Free Xros CM mode parameters are independent of each other, but their functions are the same. Free Xros CM parameters are not to be introduced. See the relevant M mode and Free Xros M mode sections.

5.9 TDI

TDI mode is intended to provide information about low-velocity and high-amplitude tissue motion, specifically for cardiac movement.

4 types of TDI mode are available:

- Tissue Velocity Imaging (TVI): this imaging mode is used to detect tissue movement with direction and speed information. In general, the warm color indicates movement toward the probe, while the cool color indicates movement away from the probe.
- Tissue Energy Imaging (TEI): this imaging mode reflects the status of cardiac movement by displaying the intensity of tissue. The brighter the color the less the intensity.
- Tissue Velocity Doppler Imaging (TVD): this imaging mode provides quantifiable direction and velocity information about the tissue.
- Tissue Velocity M Imaging (TVM): this function assists in observing the cardiac motion through a direct angle. TVM mode is also called Color Tissue M mode which has been introduced in the Color M mode chapter. See “5.7 Color M Mode” for details.

TDI imaging and TDI QA are options.

Only the phased probe supports the TDI function.

5.9.1 Basic Procedures for TDI Imaging

- Press <TDI> on the control panel in real-time scanning to enter the modes:
 - In B or B+Color mode: to enter TVI Mode, TVI mode parameters will be displayed on the soft menu.
 - In Power mode: to enter TEI Mode, TEI mode parameters will be displayed on the soft menu.
 - In PW mode: to enter TVD Mode, TVD mode parameters will be displayed on the soft menu.
 - In M mode: to enter TVM Mode, TVM mode parameters will be displayed on the soft menu.

If “Sampling Line Displaying” is not selected, then you need to press <M>/<PW> again after pressing <TDI> under M/PW mode.

- Switching between the TDI sub-modes

In TDI mode, press <C>, <P>, <M> or <PW> to switch between the modes.

- Exit TDI

- Press <TDI> to exit TDI mode and enter general imaging modes.
- Or, press on the control panel to return to B mode.

5.9.2 TDI Image Parameters

- In TDI mode scanning, the image parameter area in the top-right corner of the screen displays the real-time parameter values as follows:

- TVI/TEI

Parameter	F	G	PRF	WF
Meaning	Frequency	Gain	PRF	Wall Filter

- TVD

Parameter	F	G	PRF	WF	SVD	SV	Angle
Meaning	Frequency	Gain	PRF	Wall Filter	SV Position	SV Size	Angle value

5.9.3 TDI Image Optimization

In each TDI mode, the parameters that can be adjusted are similar to those in the color flow modes (Color, PW, and Power). See the relevant sections for details. The following introduces the specific items in TDI mode.

Tissue State

Description This function is used for fast image optimization.

Operations Adjust using the [Tissue State] on the soft menu
3 levels are provided: L, M, H.

5.9.4 TDI Quantitative Analysis (QA)

 **CAUTION:** TDI Quantitative Analysis results are provided for reference only, not for confirming diagnoses. Compare the results with those of other machines, or make diagnoses using non-ultrasound methods.

NOTE: For a better analysis result, please perform strain or strain rate analysis based on images with ECG curves.

TDI QA is applied for TVI original data analysis, for evaluating the velocity change of the same cardiac muscle with cardiac cycles.

The system provides 3 kinds of curves for quantitative analysis:

- Speed – Time curve;
- Strain – Time curve;
- Strain Rate – Time curve.

Strain:	Deformation and displacement of the tissue within the specified time.
Strain rate:	Speed of the deformation, as myocardial variability will result in velocity gradient. Strain rate is commonly used to evaluate how fast the tissue is deforming.

TDI QA Workflow:

1. Perform image scanning on cardiac muscle, freeze the image and select a range of images for analysis, or select a desired cine loop from the stored images.
Tip:
 - Images from the current scan session (already in freeze mode) or from a saved image loop can be used for TDI QA.
 - TDI QA is only available if the user has selected an image loop. If the user has selected a saved still image (just one frame), the TDI QA function is not available.
2. Start TDI QA function: use <Switch Mode> to switch the soft menu to TVI mode, press <Cursor> to show the cursor and then click [TDI QA] on the menu in the top-left corner of the screen.
3. Mark out the part of interest.
4. Select the quantitative analysis curve: click [Speed] / [Strain Rate] / [Strain] to select.
5. Save the curved image, export the data and perform parameter analysis.
6. Exit TDI QA:
 - Press <Cursor> to show the cursor, click [Exit] on the menu in the top-left corner of the screen.
 - Press <Freeze> or on the control panel.

5.9.4.1 TDI QA Screen Description

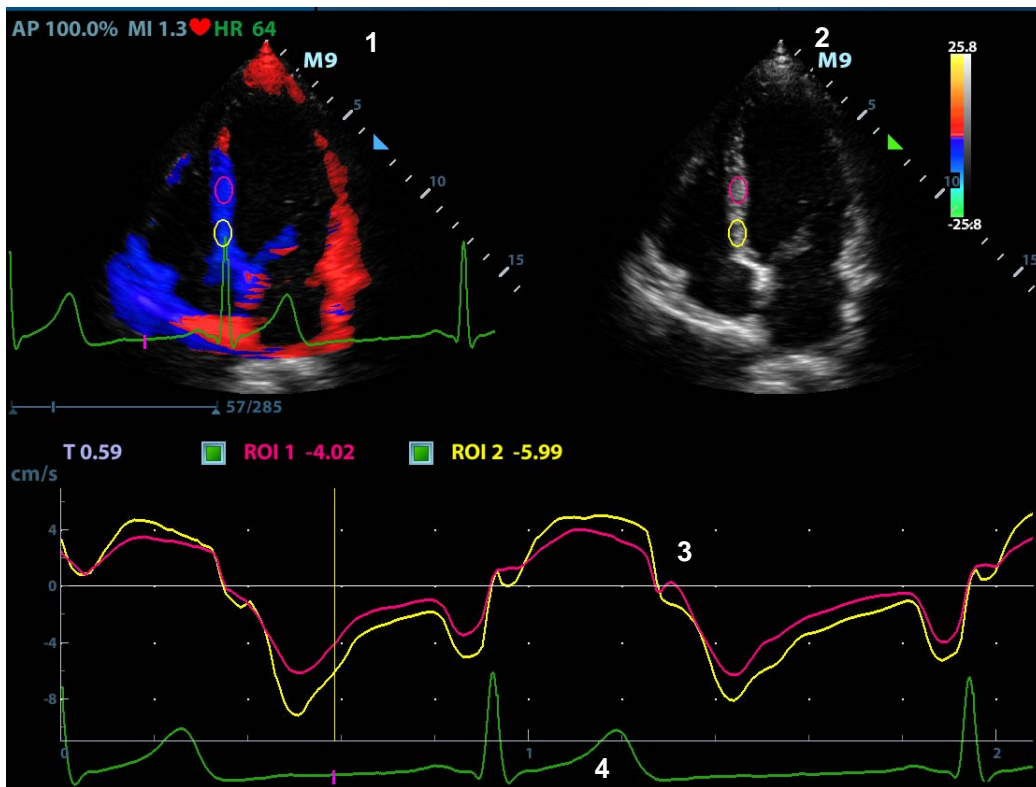

TDI QA Screen (using the Speed – Time curve as an example)

1 - TVI Cineloop window

Sample area: indicates the sampling position of the analysis curve. The sample area is color-coded, 8 (maximum) sample areas can be indicated.

2 - B Cineloop window

Tip:

- The images in the TVI cineloop window and B cineloop window are the frozen image of the same moment. Roll the trackball to review the images in the two cineloop windows.
- Sample areas are linked in the TVI cineloop window and B cineloop window.

3 - Displays the analysis curve

- The Y-axis represents the speed (unit: cm/s). [In the Strain Rate – Time curve, the Y-axis represents the strain (%). In the Strain – Time curve, the Y-axis represents the strain rate (1/s).]
- The X-axis represents the time (unit: s).
- Frame marker: a yellow line perpendicular to the X-axis which can be moved horizontally left to right (and right to left) by rolling the trackball.
- Click the checkbox beside the ROI to set whether to hide or display the QA curve.
- You can get the current X/Y-axis value by moving the cursor onto one point on the curve. If you press <Set> now, the frame marker will move to that spot.

4 - Displays the ECG trace (no ECG trace displayed here).

5.9.4.2 Basic TDI QA Procedures

Setting the ROI

This function is used for setting the TDI QA target.

Up to eight ROIs can be saved on the reference image, with the corresponding eight traces plotted simultaneously on the graph. Each ROI display has a different color, and its corresponding trace data is plotted with the same color.

There are two different methods for determining the shapes of the sample area: Standard ROI and Freehand ROI.

■ Standard ROI

1. Select [Standard ROI] on the soft menu.
2. Browse the image to a desired frame.
3. When the trackball positions the image display cursor over the reference image(s), an elliptical ROI is automatically generated and displays on the reference image(s).

The average intensity value inside the ellipse is calculated for every image in the image analysis range and plotted in the image display area.

The last generated or selected ellipse is considered to be the active ROI, and its trace plot automatically updates as the user repositions it on the reference image. Old traces are erased.

When scanning with an elliptical ROI, press <Set> to fix the ROI position and freeze its corresponding trace on the plot. A new active ROI is generated whose position is manipulated by the trackball and whose analysis curve traces will be plotted as before, while the previous ROI and trace remain fixed at the points they were saved at.

■ Ellipse ROI

1. Select [Ellipse ROI] on the soft menu. When the cursor appears in the image review area (TVI image review window or 2D image review window), it displays as a color-coded ellipse.
2. Browse the image to a desired frame.
3. Use the trackball to position the caliper on the reference image at the start point. Press <Set> to fix the start point.
4. Trace the outline of the desired ROI by moving the cursor with the trackball.
5. Press the <Set> key, and roll the trackball to create the ROI. When a suitable ROI has been drawn, confirm the ROI by pressing the <Set> key again. During the drawing course, press the <Clear> key to cancel the last point.

Press <Clear> to delete the last added ellipse ROI.

■ Delete an ROI

Press the <Clear> key to clear the last ROI. Select [Delete All] on the soft menu to clear all ROIs.

The corresponding traces for the deleted ROIs are erased from the plot.

■ Standard Height/Standard Width/Standard Angle

Use the soft menu selections [Std. Height], [Std. Width], [Std. Angle] to adjust the height, width and tilt angle of the standard ROI for the current or following ROIs.

■ Strain Distance

Sampling distance for calculating deformation. Select [Cur. Type] on the soft menu to select the corresponding value for the Strain – Time curve or Strain Rate – Time curve.

ROI tracking

This function provides a motion-compensated ROI as precise time-intensity information can be acquired using active tracking.

X Scale

Use [X Scale] on the soft menu to choose a different value. The X scale display will be changed. This function can be used to track detailed tissue information.

Smooth

Use this function to smooth the curve. The system provides 7 levels of smooth effect.

Export/Save Trace Data

1. Click [Export] on the soft menu.
2. Select the drive and enter the file name in the displayed window.
3. Select [OK] to save the data and return to the QA Analysis screen.
 - All displayed ROI traces are saved in the exported file.
 - The parameters are included in the trace file if the user has fixed a ROI.
 - After exporting, a .BMP format image is displayed in the thumbnail area in the lower part of the screen.
 - Only data from the user-selected image range is included in the exported trace file.

5.10 iScape View (Real-time Panoramic Imaging)

The iScape panoramic imaging feature extends your field of view by piecing together multiple B images into a single, extended B image. Use this feature, for example, to view a complete hand or thyroid.

When scanning, move the probe linearly and acquire a series of B images. The system pieces these images together into a single, extended B image in real time. The system also supports out-and-back image piecing.

After obtaining the extended image, you can rotate it, move it linearly, magnify it, add comments or body marks, or perform measurements on the extended image.



CAUTION:

iScape panoramic imaging constructs an extended image from individual image frames. The quality of the resulting image is user-dependent and requires operator skill and additional practice to become fully proficient. Therefore, the measurement results can be inaccurate. Exercise caution when you perform measurements in iScape mode. A smooth and even speed will help produce optimal image results.

Color iScape images are provided for reference only, not for confirming diagnoses.

- iScape is an option.
- Displaying the biopsy guideline is not allowed in iScape mode.

5.10.1 Basic Procedures for iScape Imaging

To perform iScape imaging:

1. Connect an appropriate iScape-compatible probe. Make sure there is enough coupling gel along the scan path.
2. Enter iScape: Press <Cursor> to show the cursor and click [iScape] on the menu in the top-left part of the screen. (to acquire color iScape images, enter iScape mode from B+Power mode):
3. Optimize the B mode (Power mode) image:

In the acquisition preparation status, press <Switch Mode> to switch to the [B] ([Power]) page tab to select B mode (color) image optimization. Perform measurement or add comments/body marks to the image if necessary. Tip: in iScape mode, [FOV] is limited to "W."

4. Image acquisition:

Click [Start Capture] or press <Update> on the control panel to begin the acquisition. For details, see "5.10.2 Image Acquisition."

The system enters image viewing status when the acquisition is completed. You can perform operations such as parameter adjusting. For details, see "5.10.3 iScape Viewing."

5. Exit iScape:
 - Press the button to return to B mode.

5.10.2 Image Acquisition

To create an iScape image, start with an optimized 2D (color) image. The 2D image serves as the mid-line for the resulting iScape image.

1. Press the <Update> key or click [Start Capture] on the soft menu to start the iScape image capture.
2. Scan slowly to obtain a single extended field of view image. You can also erase and retrace if the image is not satisfactory.
3. End image capture:

To end the image capture:

- Click [Stop Capture] on the soft menu, or,
- Press the <Update> key, or,
- Wait until the acquisition completes automatically.

After the acquisition is completed, the panoramic image will be displayed and the system enters iScape viewing mode.

Tip:

- During image acquisition, none of the parameters are adjustable, and functions such as measurement, comments and body marks are not available.
- ROI: a green box on the image indicating the boundary between the merged images and the unfinished images.
- Tip on the probe speed: During image slicing, the system gives feedback on the probe's moving speed in the form of colors and words. The meanings are as follows:

Status	ROI Color	Tip
Speed too low	Blue	Moving speed of the probe is too low.
Appropriate	Green	None.
Speed too high	Red	Moving speed of the probe is too high.

Guidance and precautions for even movement:

- Make sure there is enough coupling gel along the scan path.
- Always move the probe slowly and steadily.
- Continuous contact is required throughout the length of the extended image. Do not lift the probe from the skin's surface.
- Always keep the probe perpendicular to the skin's surface. Do not rock, rotate or tilt the probe during the scan.
- The system accommodates a reasonable range of motion velocity. Do not make abrupt changes in motion speed.
- Deeper scans generally require reduced acquisition speed.

5.10.3 iScape Viewing

After completing image acquisition, the system performs image splicing and then enters the iScape viewing mode.

In iScape viewing mode, you can perform image parameters setting, zooming, rotation and adding measurements, comments and body marks.

Adjusting Image Parameters

In image viewing mode, you can adjust the following parameters:

■ Image size

select [Actual Size] to display the image in its actual size.

Select [Fit Size] to display the image in a size that fits the current window. This is the system's default format.

■ Tint map

Use [Tint Map] to activate the function, as well as change the effect.

■ Ruler

Click [Ruler] to be ON on the soft menu to hide or show the ruler around the image.

■ Color Display (in Power iScape)

Select [Color Disp.] on the soft menu to display or hide the color image.

■ Color Map (in Power iScape)

Use [Color Map] on the soft menu to select the map, as in Power mode.

Image Zooming

Press the <Zoom> button on the control panel to enter image zooming mode. Rotate the button to zoom in/out on the panoramic image.

- Rotate the button clockwise to zoom in on the image.
- Rotate the button counter-clockwise to zoom out on the image.
- Roll the trackball to change the position of the magnified image.
- Press the <Zoom> key again to exit zoom mode.

Rotating the Image

For the convenience of image viewing, you can rotate the image by selecting [Rotation] on the soft menu.

Measurement, Comments and Body Marks

In iScape image viewing status, you can perform measurement, comments and body marks. The operations are the same as in B mode.

<p>NOTE: The measurement accuracy for spliced images may be degraded - exercise caution when measurements are performed on an iScape image.</p> <p>If there is a trace during the retracing, do not perform measurement across the trace.</p>
--

Evaluate Image Quality

Many variables may affect the overall image quality. It is important to evaluate the image content and quality before an image is used for diagnosis or measurements.

NOTE: iScape panoramic imaging is intended for use by well-trained ultrasound operators or physicians. The operator must recognize image items that will produce a sub-optimal or unreliable image.

The following items may produce a sub-optimal image. If the image quality does not meet the following criteria, you must delete the image and repeat image acquisition.

- The image must be continuous (no part of an image moves suddenly or disappears.)
- No shadow or absent signal along the scan plane.
- Clear profile of anatomy through the entire scan plane without distortion.
- Skin line is continuous.
- The images are captured from the same plane.
- There are no large black areas in the image.

5.10.4 Cine Review

Click [Review Cine] on the soft menu in panoramic image viewing status to enter cine reviewing mode. In cine reviewing mode, a green frame marker indicates the sequence of the currently reviewed images in the panoramic image on the left-hand side of screen.

In cine review status:

- Roll the trackball to review the captured images frame by frame.
- Click [Auto Play] to start or end auto play.
- In auto play mode, select [Auto Play] on the soft menu to change the play speed. When the speed is 0, the system exits auto play mode.
- Review to a certain image. Select [Set Begin] to set the start point. Review to another image. Select [Set End] to set the end point. In auto play mode, the review region is confined to the set start point and end point.
- Click [Return] on the soft menu to exit cine review mode. The panoramic image displays.
- In cine review mode, press <Freeze> on the control panel to return to the acquisition preparation status.

5.11 Left Ventricular Opacification (LVO)

LVO is used in conjunction with ultrasound contrast agents to enhance the imaging of blood flow and microcirculation. Injected contrast agents re-emit incident acoustic energy at a harmonic frequency which is much more efficient than the surrounding tissue. Blood containing the contrast agent stands out brightly against a dark background of normal tissue.

LVO is an option.

Only SP5-1s supports LVO (left ventricular opacification).



CAUTION:

Set MI index by instructions in the contrast agent accompanied manual.

Read contrast agent accompanied manual carefully before using LVO function.

Cardiac rhythm disturbances during cardiac studies using gas ultrasound contrast agents have been observed in the diagnostic range of Mechanical Index (MI) values. See the specific package insert for the contrast agent being used for further details.

NOTE:

Be sure to finish setting the parameters before injecting the agent into the patient to avoid affecting the image consistency. This is because the agent's acting time is limited.

The contrast agent used must comply with the relevant local regulations.

5.11.1 Basic Procedures for LVO Imaging

To perform successful LVO imaging, start with an optimized B image and have the target region in mind.

1. Acquire ECG signal.
2. Select LVO exam mode. .
3. Adjust the acoustic power experientially to obtain a good image.
Click [Dual Live] to turn it to "On" and activate the dual live function. Observe the tissue image to find the target view.
4. Inject the contrast agent, and set [Timer 1] to "ON" to start the timing. When the timer begins to work, the time will be displayed on the screen.
5. Observe the image. Use the [Pro Capture] and [Retro Capture] on the soft menu or the user-defined keys (defined as prospective capturing and retrospective capturing) to save the images. Click those soft menu controls again or press <Freeze> to end the live capture.
Perform several live captures if there are more than one sections of interest.
6. At the end of LVO imaging, set [Timer 1] to "OFF" to exit the timing function. Perform procedures 3-5 if necessary.
For every single LVO imaging procedure, use [Timer 2] for timing.
If necessary, activate the destruction function by clicking [Destruct] to turn it to "ON" and destruct the micro-bubbles left by the last LVO imaging, or to observe the reinfusion effect in a continuous agent injecting process.
7. Exit LVO.
Click [Exit] on the menu in the top-left part of the screen to exit LVO mode, or press to return to B mode.

5.11.2 Image Parameters

Parameter Area Display

When entering LVO mode, the screen displays the LVO image. If the [Dual Live] on the soft menu is "ON", both the LVO image (marked with "C") and tissue image (marked with "T") are displayed (the two window positions can be changed). Parameter area displays as follows:

Type	Parameter	Description
Contrast(LVO)	FC H	Contrast frequency.
	D	Depth.
	G	Gain.
	FR	Frame rate.
	DR	Dynamic Range.
	iTouch	iTouch status
	iClear	iClear level
Tissue	G	Gain
	DR	Dynamic Range.
	iTouch	iTouch status
	iClear	iClear level
Zoom	Z	Magnification factor
Timing (if timer is "ON")	/	In real-time mode, the time displayed is the elapsed time. In freeze mode, the timer stops working and the elapsed time is displayed.

Image Optimization

To adjust the LVO image as well as the tissue image, use <Switch Mode> key to switch the modes of the soft menu first.

The parameters in LVO mode are similar to those in B mode. See chapter B for details. Special LVO imaging parameters are introduced below.

Timer

The two timers are used to record the total time of the LVO imaging and the single time of one LVO exam.

After the image is frozen, Timer 1 is still running, and after unfreezing the image, the corresponding time can be seen.

Timer 2 stops timing when a LVO exam is frozen, and after unfreezing the image Timer 2 is off.

NOTE: The starting time displayed may be inconsistent with the actual one due to system error or some other human error. Check the agent-injecting time.

Set [Timer 1(2)] to "ON" to start timing from the moment you inject the contrast agent. The screen displays the times in the bottom-right corner.

- The time begins at 0.
- In live mode, the elapsed time is displayed. For example, **00:00:08** means the elapsed time is 8 seconds.
- If the image is frozen during timing, the timer stops working and the elapsed time is displayed.
- Set [Timer 1] or [Timer 2] to “OFF” and the timer stops running.

Micro-bubble Destruction

Function: to destroy the micro-bubbles left by the previous LVO imaging, or observe the reinfusion effect in a continuous agent injecting process.

- Entering: click [Destruct] on the soft menu to enable the micro-bubble destruction function.
- Parameters: set the parameters using the soft menu.
 - DestructAP: adjust the destruct acoustic power.
 - Des.Time: adjust the destruct time.

Dual Live

In live mode or freeze mode, set the soft menu item [DualLive] to “ON” to enable the dual live function. Both the LVO image (marked with “**C**”) and the tissue image (marked with “**T**”) are displayed (the position can be changed). You can also switch to the LVO or Tissue mode by <Switch Mode> key to adjust the corresponding parameters.

Tip:

- In dual live mode, the screen displays the LVO image and tissue image
- In freeze mode, only one cine review progress bar displays as the LVO image and tissue image are reviewed synchronously.
- Image position

Use [CEUSPos: XX] to adjust the position of the LVO image.

When it is selected as “Left”, the image displays at the left side of the screen.

Mix Map

This function combines the LVO image with the tissue image, so that the contrast regions of interest can be located.

Click [Mix: XX] to select different mixing modes: Mix C&T, Mix: Contrast.

- When the dual live function is on, you can see the mixed effect on the LVO image.
- When the dual live function is off, you can see the mixed effect on the full-screen image.

Select the map using the [Mix Map] item.

iTouch

In LVO status, you can also get a better image effect by using the iTouch function.

- Press <iTouch> on the control panel to turn the function on.

The iTouch symbol will be displayed in the image parameter area in the top-right corner of the screen once <iTouch> is pressed.

Select different levels of iTouch effect using [iTouch] on the soft menu.

- Long press the <iTouch> key to exit the function.

Image Saving

- Live capture

In live mode, you can save the images of interest by clicking [Pro Capture] and [Retro Capture] or press the user-defined save key.

- Cine saving

In live mode, press the <Freeze> key on the control panel to enter cine review status.

5.11.3 Measurement, Comments and Body Marks

The system supports image measurement, comment and body mark functions. For details, see the relevant sections.

5.12 Elastography

CAUTION: Elastography images are provided for reference only, not for confirming diagnoses.

Elastography imaging is an option.

Linear probes L12-4s and L14-6Ns under thyroid and breast exam modes support the Elastography function.

5.12.1 Basic Procedure for Elastography

1. Perform a B scan to locate the region.
2. Press <Cursor> to show the cursor, press [Elasto] on the menu in the top-left corner of the screen or press the user-defined key to enter the mode. Adjust the ROI according to the actual situation.
3. Select the probe according to the experience and actual situation.
4. Adjust the image parameters to obtain the optimized image and necessary information.
5. Adjust the ROI on the frozen image if necessary.
6. Save the image or review the image if necessary.
7. Perform measurement or add comments/body marks to the image if necessary.
8. Estimate the hardness of lesions according to the results.
9. Press to return to B mode.

5.12.2 Enter/Exit

■ Enter

Press <Cursor> to show the cursor, press [Elasto] on the menu in the top-left corner of the screen.

After entering the mode, the system displays two windows in real-time on the screen. The left one is the 2D image, and the right one is the Elasto image.

■ Exit

Press on the control panel to exit and enter the mode.

5.12.3 Pressure Hint Curve

The screen displays the pressure curve in real time:

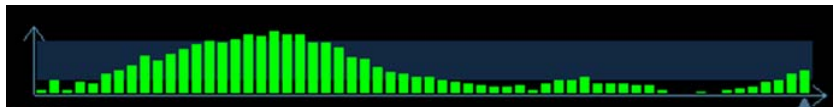

The X-axis represents time and the Y-axis represents pressure.

ROI Adjustment

Description To adjust the width and position of the ROI in Elasto imaging.

Operation When the ROI box is solid line, roll the trackball to change its position.
When the ROI box is a dotted line, roll the trackball to change the size.
Press <Set> to switch between the solid line and the dotted line status.

Smooth

Description To adjust the smooth feature of the Elasto image.

Operation To adjust the image smoothness. Adjust using the [Smooth] on the soft menu.
The system provides 5 levels of smooth function: the bigger the value the stronger the effect.

Opacity

Description To adjust the opacity feature of the Elasto image.

Operation Use [Opacity] on the soft menu.
The system provides 5 levels of opacity function: the bigger the value the stronger the effect.

Invert

Description To invert the E color bar and therefore invert the colors of benign and malignant tissue.

Operation Click [Invert] on the soft menu.

Single E

Description To switch between the B+E dual window and the single E window.
E represents the Elastography image.

Operation Click [Single E] on the soft menu. When the button is highlighted in green, the screen displays the single window E image.

Map

Description To select different maps for observation.

Operation Use [Map] on the soft menu to select the map.
The system provides 6 maps, including 1 grayscale map and 5 color maps.

Tip: In Elasto imaging mode, image magnification is not available.

5.12.4 Mass Measurement

Press <Measure> to enter measurement status.

You can measure shell thick, strain ratio, strain-hist, etc.

For details, see [Advanced Volume].

5.12.5 Cine Review

Press <Freeze> or open an elastography imaging cine file to enter cine review status.

5.13 Stress Echo

Stress Echo is an option.

The following probes under certain exam modes support stress echo function:

- Cardiac exam modes: P10-4s/P7-3Ts/SP5-1s
- SP5-1s supports contrast stress echo function in LVO mode.



CAUTION:

Stress echo data are provided for reference only, not for confirming diagnoses.

5.13.1 Overview

The Stress Echo feature allows you to capture and review cardiac loops for multiple-phase (multiple-stage) Stress Echo protocols.

Stress Echo data consists of Stress Echo loops, wall motion scores, and all other information pertaining to the Stress Echo portion of a patient examination.

A loop is a clip that displays the motion of an entire heart cycle, or from the beginning systole to the end systole, as indicated by the R-wave of the ECG trace and determined by the QT – Time Table.

The loops in a given protocol are acquired by stages (phases), according to stage configuration (continuous (prospective) or retrospective (non-continuous)).

- Loops in non-continuous stages are limited to a specified loop-per-view maximum (such as four). View labels can only be selected in the configured order. Acquisition is retrospective - when you press the <Save> key on the control panel, the system saves the previously acquired images.
- Loops in continuous stages are limited by time rather than a maximum number of loops - the system stops acquisition after two minutes. Acquisition is prospective - when you select the stage label and then press the <Save> key on the control panel, the system starts saving newly acquired images. In some protocols, the system will jump to Select Mode after retrospective saving.

When images are saved, the system places a green checkmark to the right of the view or continuous stage and then shifts the red mark to the next view or next stage.

5.13.2 Stress Echo Acquisition Procedure

To acquire Stress Echo loops, you must enable the ECG function.

1. Use the proper probe and cardiac-related exam mode, press <Stress Echo> on the control panel to enter stress echo imaging.
2. The system displays the “Select Protocol” window with the protocol selections. Select the desired protocol and then click [OK].

The system displays the real-time imaging screen.

If the Stress Echo manual ROI option is selected in the Maintenance dialog box ([Setup]->[Stress Echo Preset]->[Maintenance]), the system also displays a region of interest (ROI). If Acquire Mode is set as Full-screen in Maintenance, then no ROI box is displayed. For details, see “5.13.5 Maintenance and Protocol.”

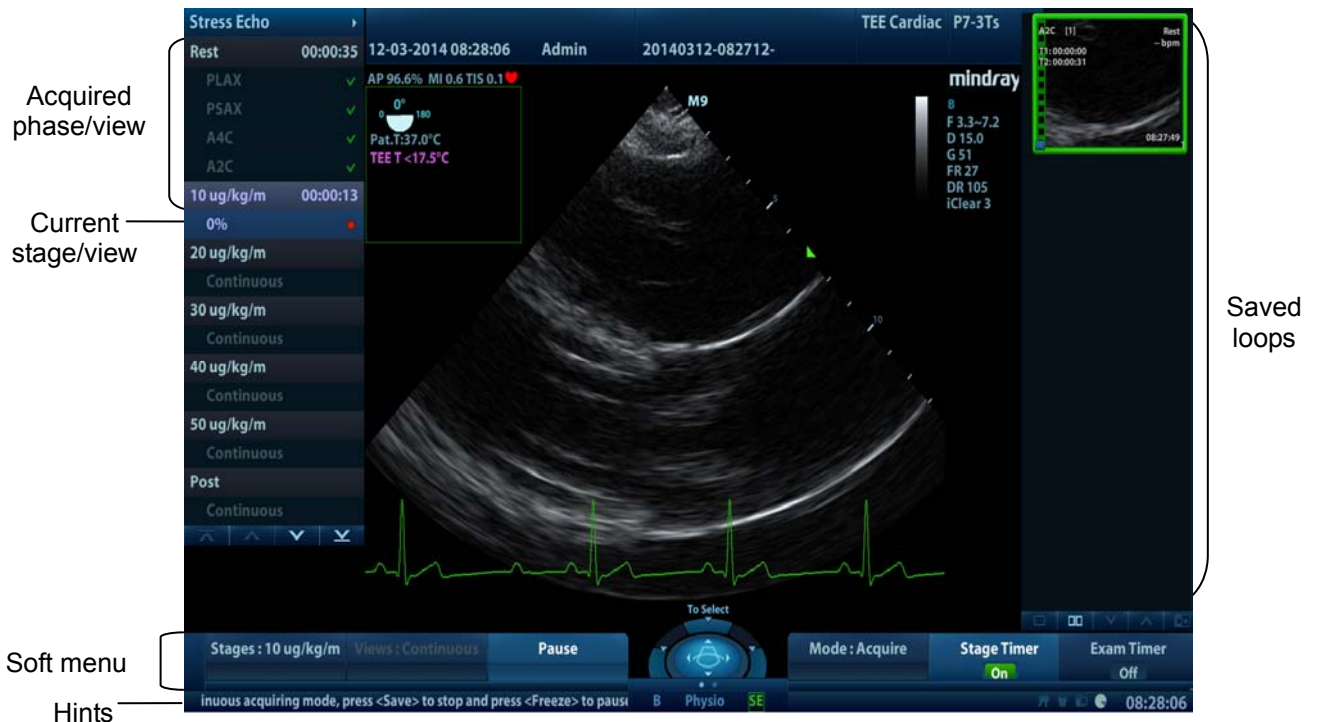

3. According to the help information in the bottom of the screen, if an ROI is displayed, adjust the ROI size and position. Press <Update> key on the control panel to confirm the ROI.
 Tip: When you confirm the ROI size by pressing <Update>, you cannot adjust the ROI size during acquisition. You can only adjust the ROI position using the trackball.
4. Press the <Save> key on the control panel to start acquisition.
 The system displays the Protocol window on the left of the screen, listing the phases for the selected protocol along with the first phase views (phases are stages). The system selects the first view for acquisition by default, indicating the selected view by placing a red mark to the right of the view name.
5. Proceed through each view in each stage according to the following instructions:
 - Non-continuous stages:
 - To save acquired images for the selected view, press the <Save> key on the control panel. The system goes to the next view for acquisition by default, saved views are marked with a green “√.”
 - Click to select [Stages XXX] or [Views XXX] on the soft menu to select the stage and view for image acquisition (or reacquisition). Press the <Save> key to start acquisition.
 Tip: Views can be re-acquired until you click [End Acquisition].
 - If the protocol contains continuous stages (for alternative workflows), then proceed through each continuous stage according to the following instructions:
 - To begin saving acquired images for the selected stage, press the <Save> key on the control panel.
 The system displays a percentage marker below the selected stage indicating the progress of the continuous capture.
 - To stop saving acquired images for the selected stage, click [Pause] on the soft menu or press <Freeze> directly. The percentage stops increasing.
 - Select [Continue] or press the <Freeze> key again to continue.
 - To end the current acquisition, press <Save> on the control panel.
 - To select another continuous stage, select [Stage XXX] on the soft menu.
 - Suspending is not allowed under continuous exam.

When acquisition is complete for each stage, the system advances to the next stage. If the stage is non-continuous, the system displays the stage views. When image acquisition is completed for all views and continuous stages, the system switch to Select Mode.

6. To start or restart the timer, click [Stage Timer]/[Exam Timer] on the soft menu to turn it on.

The Stage time is displayed to the right side of each stage in the protocol list, while the Exam time is displayed in the bottom-left area of the monitor.

Each saved image will be marked with two times T1 and T2. T1 refers to the total time of the whole acquisition, while T2 indicates the time the acquisition lasted for a certain stage.

7. To review loops before ending acquisition, set [Mode: XX] to “Review/WMS” on the soft menu. You can redisplay the real-time imaging screen to continue acquisition by clicking [Mode: XX] to be “Acquisition” on the soft menu.
8. To end the acquisition and review the acquired images, click [End Acquisition].

NOTE: When the acquisition is ended, no stress echo image acquisition can be performed for the same exam.





5.13.3 Selecting Preferred Stress Echo Loops (Select Mode)

The selected clips are used for analysis in the review mode and wall motion scoring mode. Select Mode is used to select the best loops of the examination.

When the acquisition is ended, select mode is enabled automatically.

In Select Mode, you can select the representative loop (“preferred” loop) for each view.

To select “preferred” loops:



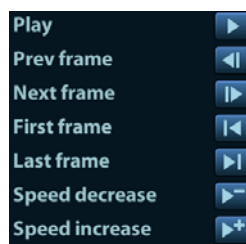







1. Use the <Switch Mode> key and <Update> key according to tips in the trackball hint area or set [Mode: XX] to “Select” on the soft menu to enter the Select Mode, or the system enters the Select Mode directly after the acquisition is finished.
2. Select the loop. Use the buttons displayed during Select Mode to designate another loop or another view for display.
 - Use [Stage: XX] or [View: XX] on the soft menu to select the target stage/view.
 - Single-click a clip to select the clip for current stage/view and zoom in the clip to the full-screen.
 - Double-click a clip. The clip will be magnified.
 - Click , ,  or  on the right side of the screen or [Page:X/X], [First Page/Last Page] to display another loop in the current view.
 - Click buttons on the left side of the screen to view the cine files by frame.



3. Select the stage and view to display all loops for the view and then continue designating the “preferred” loop for each displayed view until all views are completed.

Description of select mode controls:



Control	Selection	Description
Soft menu controls	Stage: XX	To find the stage and press it to select it.
	View: XX	To find the view and press it to select it.
	Mode: XX	To switch the mode status.
	1. Clip /2. Clip /3. Clip /4. Clip	For selecting views in the selected stage.
Page turning button	Next 	Next four Clips.
	Previous 	Previous four Clips.
	First 	Go to "first" Clips.
	Last 	Go to "last" Clips.
Menu controls	Play	Click to play/stop cine play.
	Prev frame 	See previous frame of the cine file.
	Next frame 	See next frame of the cine file.
	First frame 	See first frame of the cine file.
	Last frame 	See last frame of the cine file.
	 / 	Decreases or increases playback speed.

Control	Selection	Description
Other menu controls	Text "On"/"Off"	Function that turns the screen graphic text "On" or "Off." The function is the same as the Labels on/off icon at the top of the screen. Information includes: name of level, name of view, heart rate, time stamp acquisition, timers, frame slider, loop ID, clip control. For the cine without distributed view, the name of level and name of view are displayed in "--".
	Apply edit all	Clip edit applied to all clips taken.
	Clip Length	Specify the clip segments: systole, diastole, full cycle or user-defined.
	Bookmark Review 	For continuous acquisition, when the bookmark is set to "On", only the selected loops for the current view can be displayed.
	Delete Unselected	Delete clips that are not selected. If selected, the system will delete all clips that are not selected after the exam is ended.
	Suspend exam	Pauses the stress echo exam but does not end the stress echo exam. When a stress echo exam is suspended, the user can perform image acquisition of all other imaging modes, or perform operations such as measurement.
End SE exam	End the stress echo exam.	

5.13.4 Review/WMS Mode

Review/WMS mode is used by cardiologists to evaluate clips for cardiac wall motion abnormalities. Different views from different stages are selected for comparison across a wide variety of combinations. The most common workflow is to compare "same views" but at "different stages" of the exam (e.g., PSLA view, Rest stage compared to PSLA view, Post-exercise stage).

5.13.4.1 Enter review mode

Set [Mode: XX] on the soft menu to "Review/WMS" mode or click [Review/WMS] on the menu on the left side of the screen.

1. Set [Shuffle Mode] to "On" on the soft menu.
2. Select the label of the phase or view (for example, Rest or Long Axis) on the right part of the screen.



The system displays all loops that represent the selected phase or view.

- To display phases for the selected view(s)

1. To include a phase or view for display, select the leftmost, gray box to the left of each required phase and/or view.

The system inserts a checkmark into each selected gray box.

2. To exclude a phase or view from display, select the blue box to the left of each required phase and/or view.

The system inserts a red X into each selected box, like .

3. Select the Display Selected Loops button  on the right.

The system displays the selected phases for each selected view side by side.

- To display all views for a specific phase:

Select the phase label (for example, Rest).

- To display all phases for a specific view:

Select the view label (for example, PLAX).

The system displays all phases for the selected view.

- To display a loop in full-screen format:

1. Double-click the loop to display in full-screen format.
2. Double-click the loop again to display the loop in its initial size, select the loop again.

Description of review/WMS mode keys (keys with the same function as in select mode are not described below):

Key	Description
Shuffle	<p>Perform side-by-side comparison of the same views at different stages (PLAX, PSAX, A4C, A2C at “Rest” compared to PLAX, PSAX, A4C, A2C “Post-Exercise”). Clips are synchronized.</p> <p>Selection: On, Off</p> <p>Under [Shuffle Mode] “Off” status, when you select one stage, all view loops are displayed on the screen; when you select one view, all loops of the same view in different stages will be displayed on the screen.</p> <p>Set [Shuffle Mode] to “Off”, the system will select loops of first two views of the first two stages to display automatically. If you choose [Shuffle Back], then loops of the next two views of the first stages will be displayed. If you click [Shuffle Back] again, loops of the first two views in the 3rd and 4th stage will be displayed.</p> <p>In the meantime, if you choose one stage, loops of all views under this stage will be displayed on the screen (4 at most), and choosing one view will lead to loops of this view in different stages be displayed (4 at most).</p>
Shuffle Forward/Back	Turn the pages of the current filtered views.
Display Selected 	Displays loops of all the stages and views selected.

5.13.4.2 Wall Motion Scoring

The WMS-Report lists user-assigned wall motion scores and associated data.

The Wall Motion Score (WMS) measurement is an application prepared for assisting in stress echo semi-quantitative evaluations of abnormalities with left ventricular wall motion or changes in wall thickness. The left ventricle is divided into segments for scoring to evaluate the degree of

abnormality from the sum of the scores in each segment using the motion of the walls of the entire left ventricle.

You can assign wall motion scores to specific portions within each view (representative loop). You can also assign a normal wall motion score (WMS) to the currently selected view or to all displayed views.



Two methods of chamber segment division, ASE 16 and ASE 17, are supported. In addition, each segment has 3 kinds of scoring method: 4, 5 and 7 points.

To assign a wall motion score (WMS):

1. Select a colored number in the bottom-right area of the screen.

The meanings and colors used in segments are listed in the table below.

Score	Meaning	Color
1	Normal	Green
2	Hypokinesis	Yellow
2.5	Severe Hypokinesis	Khaki
3	Akinesis	Blue
4	Dyskinesis	Red
5	Aneurysm	Purple

2. Roll the trackball to select the value and then click the target segments, then the segment is assigned with a value.
3. Repeat step 2 to perform value assign for all segments.
 - To assign a normal wall motion score (WMS) to all currently displayed loops:
Select [Set All Normal] on the soft menu or click  on the right part of the screen.
 - To assign a normal wall motion score (WMS) to the currently selected loop:
Select [Set Current Normal] on the soft menu or click  on the right part of the screen.

5.13.5 Maintenance and Protocol

5.13.5.1 Maintenance

Enter “<Setup>->[Stress Echo Preset]->[Maintenance]” to enter the screen.



Item	Function Description
Acquire mode	Set the type of ROI: manual ROI or full-screen.
Overlay	Select the items to be labeled on each loop.
WMS score type	Set the chamber segment division method.
QT-Time table	To customize the length of systolic duration acquired for a specific heart rate. If “Trigger” is selected as “R-R Systolic” in Protocol Editor, it will store the clip duration. You can add and remove entries in this table. You can also load the factory defaults.
Heart rate	Enter the heart rate.
Syst. duration	Enter the systolic duration.
Load factory	To reset the QT time table.

QT-Time Table Operation:

- To add an entry:
Enter a heart rate and the referring systolic duration and then click [Update].
- To delete an entry:
Select the required heart rate and systolic duration pair from the QT – Time Table and then click [Delete].

5.13.5.2 Protocol Edit

You can create, edit and delete Stress Echo protocols using the Protocol Editor dialog box. Access the Protocol Editor dialog box by clicking [Protocol] in [Setup]->[Stress Echo Preset]->[Protocol], or clicking [Edit] on the Select Protocol screen as shown in the figure below:

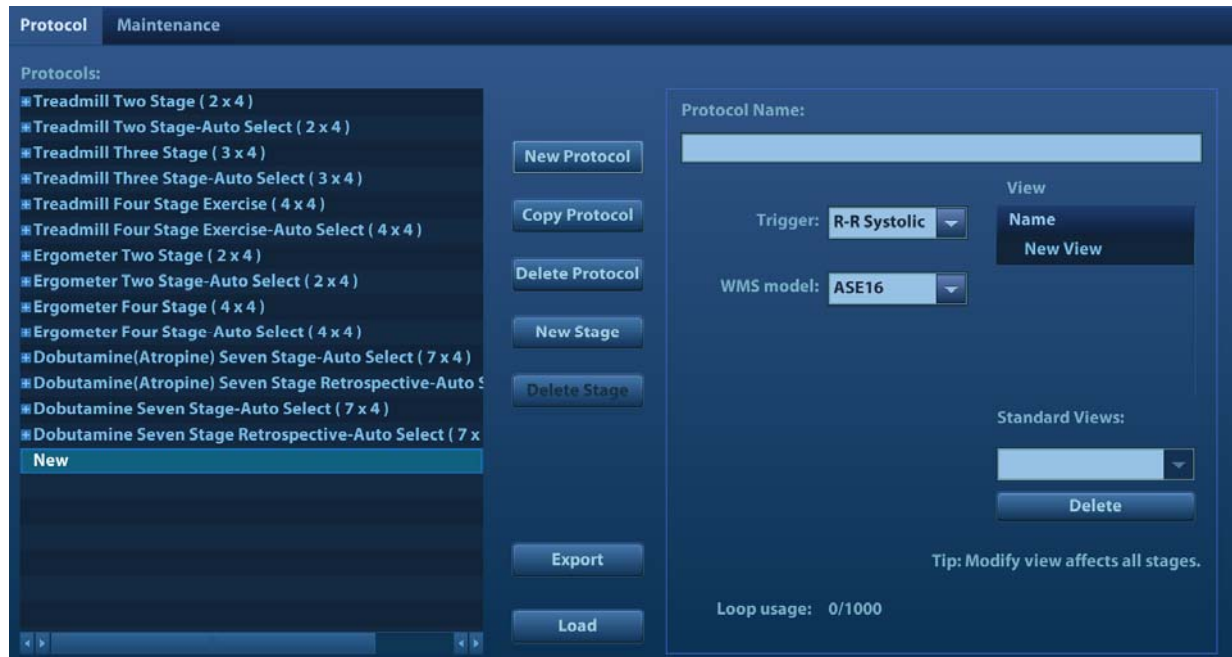

Item	Function Description
Protocol name	Enter the protocol name.
Trigger	Set the trigger type.
WMS model	Set the chamber segment division method.
Loop usage	Displays the acquired loop number as well as the total usable loop number.
View	Set the views for each stage.
Standard view	Set the standard view.
Load	Import a protocol.
Export	Export a protocol.
New protocol	Create a new protocol.
Copy protocol	Create a new protocol with an existing one.
Load	Load an existing protocol.
Save	Save the changes to the protocol.
Delete protocol	Delete the protocol.
New stage	Create a stage for the current protocol.
Quit	Remove the Protocol Editor dialog box.

Creating a Stress Echo Protocol

To create a stress echo protocol:

1. Click the [New Protocol] button to the right of the Protocol Editor dialog box.
2. Enter the protocol name in the Protocol Name box at the top.

3. For each view (all views display for each phase):
 - (a) Select "New View" in the View list.
 - (b) Select a standard view from the Standard View list. Or you can customize the view name.
4. For each phase in the protocol:
 - (a) Select "new" in the Stage list.
 - (b) Enter a phase name.
 - (c) Select "Auto Select", the system jumps to Select Mode after retrospective acquisition.
 - (d) Select the required option from the Clip Capture drop-down list.
 - (e) Select the number of loops to acquire (per view in the selected phase) in the Loops list (for non-continuous stages).
 - (f) Select the type: exercise or drug.
5. Click [Save] to save changes and quit.

Editing or Deleting a Stress Echo Protocol

- To delete a protocol:

Select the protocol or one of its component phases or views and then click [Delete].

- To Edit a Stress Echo Protocol:

1. Click an available protocol on the Select Protocol screen.
2. Click [Edit] to enter the Protocol Editor screen.
3. Edit the protocol as described in the create protocol.

5.13.6 Saving Stress Echo Data

Stress Echo data consists of Stress Echo loops, wall motion scores, and all other information pertaining to the Stress Echo portion of a patient examination.

When the exam is ended, the system will save all images within the exam.

5.13.7 Exiting the Stress Echo Feature

To exit the Stress Echo feature:

Press the <End Exam> key on the control panel or click [End SE exam] on the screen.

5.13.8 Stress Echo (Contrast)

Switch to SP5-1s probe and select LVO exam mode, the system enters LVO mode directly. In the meantime, press <Cursor> to show the cursor and press <Stress Echo> on the control panel to enter the function.

The procedure of contrast stress echo function is similar to the ordinary stress echo feature. For details, see the above corresponding chapters.

You can also activate SE by suspending the exam in cardiac exam mode of SP5-1s after entering SE mode and then switch to LVO mode.

5.13.9 Measurement and Report

Suspend the stress echo exam by selecting [Suspend Exam] on the soft menu. Press the measurement related keys or buttons to enter cardiology measurement. For details, see the [Advanced Volume].

Reports contain the entered indication, if any, and also any entered comments that are specific to the report. You can include or exclude data from specific phase(s). You can preview and print the report for the currently selected mode. You can also enable colored report printing in Maintenance.

■ Entering Indications or Comments for the Reports

You can enter an indication for display in Stress Echo reports.

To enter an indication:

1. Press <Report> on the control panel to open the report.
2. Use the keyboard to enter text in the Indication dialog box and then click [OK].

5.14 Tissue Tracking Quantitative Analysis (QA)

Apart from the TDI imaging function, the system also provides a tissue tracking QA function for myocardial movement evaluation.

Using the tissue tracking QA function, the ultrasound system will scan each pixel position by frame within the cardiac cycle, then use the region matching method and auto-correlation searching method to trace each spot and calculate the movement, so as to determine myocardial motion in a more quantitative way.

 CAUTION: Tissue Tracking Quantitative Analysis images are provided for reference only, not for confirming diagnoses.

Tissue Tracking QA is an option.

5.14.1 Basic Procedures for Tissue Tracking QA

1. Open a saved B mode cardiac cine file (a cin. format file which contains more than 1 cardiac cycle (with 2 R waves) and ECG signal).
2. Press <Cursor> to show the cursor and click [Tissue Tracking QA] on the menu in the top-left corner of the screen to activate the function:
 - a) You can determine the image of interest by previewing the image
 - b) To find the image of interest, click [Cycle] on the soft menu to select.
3. Select the corresponding section name on the soft menu and locate one frame image with good image effect by cine play. Use the cursor to set the reference point (for details, see chapter "5.14.4 Myocardial Boundary Tracing"):
 - Long axis section: use the "3-point" method or "Manual" method to set
 - Short axis section: enter multiple points (at least 6 points) using the cursor manually to set.
4. After reference points are set, the system will display the boundary of the endocardium and epicardium. Adjust the thickness if necessary. For details, see "5.14.4 Myocardial Boundary Tracing" chapter.

If the traced result is poor, click [Reload] on the soft menu to re-trace the reference points, or make fine adjustments to the points using the cursor.

If the cycles are not adequate to provide the information, switch to another cycle to trace.

5. Click [Start Tracking] on the soft menu to start the tracking function. Adjust the parameters if necessary.

Click [Edit] on the soft menu to display the cursor. Roll the trackball and press <Set> to re-select the trace reference points(inner dots of the curve). Move the cursor to the exact boundary position and press <Set> again to set the right place. Click [Start Tracking] to start tracking again.
6. Click [Accept & Compute] on the soft menu to calculate and display the curve. Adjust the parameters if necessary.
7. Click [Bull's Eye] on the soft menu to see the result.
8. Click [Data Export] on the soft menu to export analyzed data.
9. Click [Exit] on the soft menu.

5.14.2 Tissue Tracking QA Screen Description

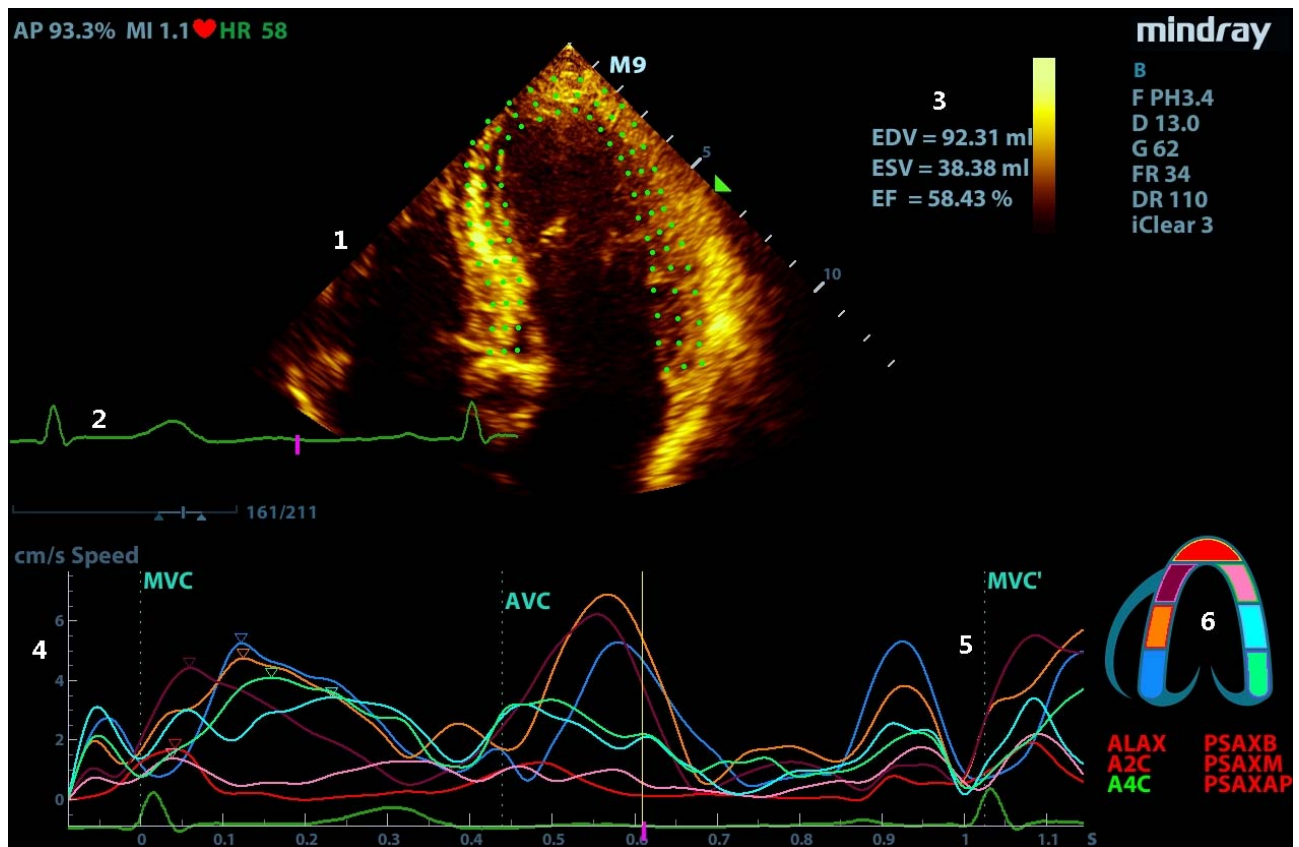

1 - Displays the image used to generate the trace curve

2 - Displays the ECG trace

3 - Displays the measurement and calculation results:

EDV:	maximum value of the end diastolic volume during the trace.
EDA:	maximum value of the end diastolic area (Left Ventricular) during the trace.
ESV:	maximum value of the end systolic volume (Left Ventricular) during the trace.
ESA:	maximum value of the end systolic area (Left Ventricular) during the trace.
FAC:	Fractional Area Change = $(EDA - ESA)/EDA$. This parameter is available in the short axis section.
EF:	Ejection fraction. This parameter is available in the long axis section.
HR:	Heart rate.

The system also displays the TPSD value on the Bull's Eye graph:

Time to Peak Standard Deviation (TPSD):

$$TPSD = \sqrt{\frac{\sum_{i=1}^N (TP_i - \overline{TP})^2}{N}}$$

Where the standardized value of time to peak data: $\{TP_i / i \in [1, N]\}$. (N is the number of time to peak data) Average standardized value of time to peak data: \overline{TP}

4 - Display curve: Velocity/Displacement/Strain/Strain Rate. Each curve on the image is matched with a certain segment in the cardiac segmentation model (6), identified by different colors.

Velocity curve	The X-axis represents time (s); The Y-axis represents velocity (cm/s).
Displacement curve	The X-axis represents time (s); The Y-axis represents displacement (mm).
Strain curve	The X-axis represents time (s); The Y-axis represents deformation of the tissue (%).
Strain-rate curve	The X-axis represents time (s); The Y-axis represents strain by time (s ⁻¹).

5 - Displays the corresponding time of AVO (aortic valve open)/AVC (aortic valve close)/MVO (mitral valve open)/MVC (mitral valve close).

6 - Displays the cardiac segmentation model. Each segment name is illustrated beneath the model.

- In the figure,  marks the peak position of the curve.
- Click on a segment in the cardiac segmentation model. The segment turns gray and its corresponding curve no longer displays.
- You can get the current X/Y-axis value by moving the cursor onto one point on the curve. If you press <Set> now, the frame marker will move to that spot.
- If the segment is filled with "XXX", it means that this segment is not well tracked.

5.14.3 Select Image and Cardiac Cycle

You can select images with a better image quality to get a better analysis result.

- Switch cine files

1. Press <Review> on the control panel to enter review status
2. Double-click the target file
3. The system closes the currently displayed file and switches to the newly selected file.

- Switch cardiac cycles within the cine file

After a cine file with more than one cycle is opened, the system displays a thumbnail of each cardiac cycle on the thumbnail area. Use [Cycle] on the soft menu to select directly.

5.14.4 Myocardial Boundary Tracing

- The system provides two kinds of tracing methods for two kinds of sections:
 - Long axis section (A4C, A2C, ALAX): the 3-point method and manual tracing method are both available.
 - 3-point method

As shown in the following figure, after pressing <Set> to place 3 points clockwise on the image, the system generates the trace automatically.

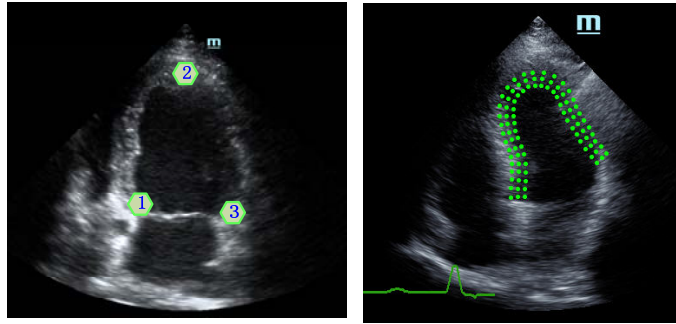

➤ **Manual trace method**

Press <Set> and roll the trackball along the boundary to add the trace points gradually. After the trace is finished, press <Set> twice to finish tracing.

At least 6 points should be determined by you before the system generates an automatic trace.

- Short axis section (PSAX B, PSAX M, PSAX AP): only manual tracing is available.

■ **Retracing**

If the current trace is not satisfactory, click [Reload] on the soft menu to clear the trace and start another tracing.

During the trace, press <Clear> to clear already-traced items.

■ **Make fine adjustments to the trace**

You can make fine adjustments to the trace:

1. In tracing curve adjusting status, the cursor becomes .
2. Move the cursor to the editable point (inner dotted line of the curve) and press <Set>.
3. Roll the trackball to drag the curve to the desired position. Press <Set> again to set the point in the new position.
4. Repeat steps 2-3 to complete all points that need adjustment.

In tracking status, click [Edit] on the soft menu to enter the status.

5.14.5 Operation Controls

Switch the operation controls

- [Start Tracking]: start tracking.
- [Accept & Compute]: start calculation and display the curve.
- [Exit]: exit tissue tracking.
- [Parameter]: select the curve type.
- [Bull's Eye]: turn on/off bull's eye and the peak data table.

View Selection

Before tracing, click to select the corresponding view.

- [A4C]: apical four-chamber view.
- [A2C]: apical two-chamber view.
- [ALAX]: apical long axis view.
- [PSAX B]: short axis base view.
- [PSAX M]: short axis mid view.
- [PSAX AP]: short axis apex view.

Parameter Adjustment

- [Thickness]: adjusts the tracing thickness, i.e., the distance between the endocardium wall and the tracking points on the epicardium.
- [Tracking Points]: adjusts the number of points within the segment.
- [Cycle]: select the next cycle.
- [Display Effect]: turns on/off the arrow vector graphical display of the myocardial movement.

Image display

According to the status of the current section, click buttons on the soft menu to check the corresponding time.

- [AVO]: displays the aortic valve open time.
- [AVC]: displays the aortic valve close time.
- [MVO]: displays the mitral valve open time.
- [MVC]: displays the mitral valve close time.

5.14.6 Bull's Eye Display

After tracking, the system displays a Bull's Eye graph for judging the reverse movement or scope of myocardium.

1. Click [Bull's Eye] on the soft menu to turn the function on:

You can acquire:

- Time to peak value and peak value of the 17 segments;
 - Display measurement result EDV/ESV/EF/TPSD.
2. Use [Parameter] on the soft menu to see a bull's eye graph for different parameters.



“-” will display in the table to indicate those segments that are not well tracked.

5.14.7 Measurement/Comment

In tissue tracking QA mode, only the Time measurement is available. For details, see the Operator's Manual [Advanced Volume].

Comments and Body Mark operations are the same as in other modes.

5.14.8 Data Export

The system provides a data exporting function, so that you can export calculation results for analysis (for instance, SPSS analysis).

Click [Data Export] on the soft menu to export analyzed data for each segment in .csv format.

6 Display & Cine Review

6.1 Splitting Display

The system supports dual-split and quad-split display format. However, only one window is active.

- Dual-split: press the  key on the control panel to enter dual-split mode.

Under Dual-split mode, press <Freeze> to freeze the image and then use  to switch between the two images.

Press on the control panel to exit.

Modes support dual-split display: B mode, Color mode, Power mode, PW mode, CW mode, M mode and Color M mode.

- Quad-split: press the  key on the keyboard area on the control panel to enter the quad-split mode.

Under Quad-split mode, press <Freeze> to freeze the image and then use  to switch between the four images.

Press on the control panel to exit.

Modes support quad-split display: B mode, Color mode and Power mode.

- Single display: under dual-split or quad-split mode, press  to enter single window mode.

6.2 Image Magnification

NOTE: Zooming an image changes the frame rate which tends to change the thermal indices. The position of the focal zones may also change, which may cause the peak intensity to occur at a different location in the acoustic field. As a result, the MI may change.

6.2.1 Spot zoom



To use the function, use the  knob on the control panel.

1. Press <Zoom> to enter the sample volume definition status.
2. Roll the trackball to change the box size and position. Press <Set> to toggle between setting the size and position, or rotate the <Zoom> knob to adjust the size. After the sample volume is set, press the <Zoom> key again to enter spot zoom status.
3. Rotate the <Zoom> knob to change the magnification factor. The image magnification factor value will display in real time in the image parameter area. For example, **Z1.3** indicates that the magnification factor is 1.3.
4. Press <Zoom> again to exit spot zoom.

Tip:

- Spot zoom can only be achieved on real-time images.
- The size and position of the sample volume box change along with the scanning depth and area.

6.2.2 Pan zoom



To use the function, use the knob on the control panel.

1. Rotate the <Zoom> knob to directly enter the pan zoom status. Image-in-image is displayed.
2. Magnification factor adjustment: rotate the [Zoom] knob to change the magnification factor. The image magnification factor value will display in real time in the image parameter area. For example, **Z1.3** indicates that the magnification factor is 1.3.
3. Press <Zoom> to exit pan zoom.

6.2.3 iZoom (Full Screen View)

Function: to magnify the image in full screen.

Procedures:

1. Press  on the keyboard area on the control panel to zoom in on the image. The zoom area includes the image area, parameter area, image banner, thumbnail area and so on.
2. Press the key again to zoom in on the image area only.
3. Press the key again to exit iZoom.

6.3 Freeze/Unfreeze the Image.

Press the <Freeze> key on the control panel to freeze a scanning image. In freeze mode, the probe stops transmitting acoustic power, and all images and parameters are frozen.

Tip: After freezing an image, the system may enter cine review, measure, comment adding or body mark mode, depending on what has been preset. (Setting path: [Setup] → [System Preset] → [Image] → “Freeze Config.”)

Press <Freeze> in freeze mode to unfreeze the image, and the system continues image scanning.

6.3.1 Imaging Mode Switching When Frozen

Imaging mode switching in freeze mode follows these principles:

- In splitting display B mode, press <Dual>/<Quad> to switch between the windows. Press <Single> to exit splitting display mode and enter the image of the currently activated window in full screen.
- In freeze mode, the system supports imaging mode switching between the sub-modes (only for the activated window). For example, if the frozen image is in B+C+PW mode, the system supports imaging mode switching between B+C+PW, B+C, B+PW and B by pressing <C> or <PW>.
- The imaging mode and parameters of an unfrozen image are the same as those before freezing. The display format is the same as that before being unfrozen.

6.3.2 Imaging Display Format Switching When Frozen

Image display format switching in freeze mode follows these principles:

- 2D+PW (press <Freeze> in 2D+PW imaging mode)

If the imaging mode before freezing is 2D (frozen) + PW (real time) or 2D (real time) + PW (frozen), then in freeze mode, you can switch between 2D (frozen) + PW (activated) or 2D (activated) + PW (frozen) by pressing the <Update> key on the control panel.

- Dual/quad splitting display mode (press the <Freeze> key in dual/quad splitting display mode)
 - When entering freeze mode, the default activated window is the real-time window before freezing. Other image windows display the corresponding cine memories. If a certain cine memory is empty, then no image is displayed.
 - Press [Dual]/[Quad] to switch between dual-splitting and quad-splitting modes, current active window is marked with a highlighted M9.
 - Press <Single> on the control panel to enter the single display format, which displays the currently activated window. In single display format, press <Dual>/<Quad> to return to splitting display mode.
 - Unfrozen: in splitting display status, when you unfreeze the image you can only unfreeze the image in the activated window, other images remain frozen. In single-window display status, the system displays the single image after being unfrozen.

6.4 Cine Review

After pressing the <Freeze> key, the system allows you to review and edit the images prior to the image being frozen. This function is called cine review. The magnified images can also be reviewed after the <Freeze> key is pressed, and the operating method is the same. You can perform zoom, measurements, add comments and body marks on the images being reviewed.

The system supports manual review as well as automatic review. The default setup is Manual Cine, but you can switch between Auto Cine and Manual Cine.

In addition, the system supports the images reviewed along with physiological waveforms, if the detection of physiological waveforms is performed.



CAUTION:

Cine Review images can be inadvertently combined in-between separate patient scans. The Cine Review memory must be cleared at the end of the current patient exam and before starting the next new patient exam by pressing the <End Exam> key on the control panel.

Cine files stored in the system's hard drive shall contain patient information, to avoid the selection of an incorrect image file and potential misdiagnosis.

6.4.1 Entering/Exiting Cine Review

- To enter Cine Review:
 - Enter “[Setup] → [System Preset] → [Image] → “Freeze Config.” to set “Status after Freeze” to “Cine.” The system enters manual cine review status once <Freeze> is pressed to freeze the image.
 - Open cine files in thumbnail, iStation or Review. The system enters automatic cine review status.
- To exit Cine Review:

Press <Freeze> or and the system will return to image scanning and exit cine review.

6.4.2 Cine Review in 2D Mode (B/B+Color/B+Power/B+TVI/B+TEI)

■ Manual Cine Review:

After entering cine review in 2D mode, roll the trackball to review the cine images on the screen one by one.

If you roll the trackball to the left, the review sequence is reversed to the image-storing sequence, and the images are displayed in descending order. If you roll the trackball to the right, the review sequence is the same as the image-storing sequence, and the images are displayed in ascending order. When you review images to the first or last frame, rolling the trackball further will display the last or first frame.

The cine progress bar at the bottom of the screen (as shown in the figure below):

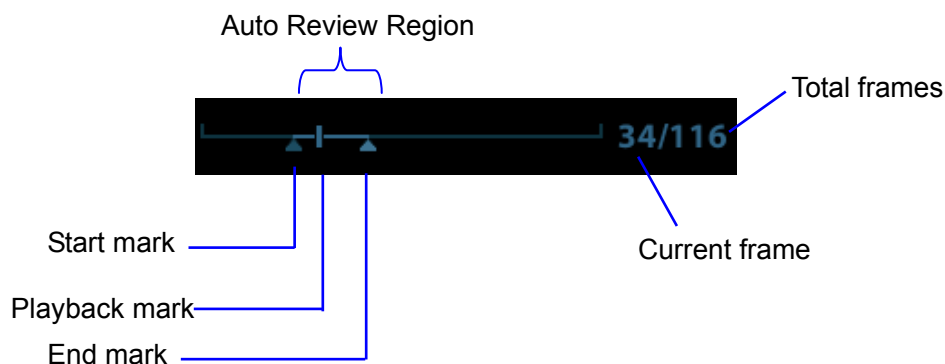

■ Auto Review

● Reviewing all

- In manual cine review status, click [Auto Play] (not selecting "Stop") on the soft menu to activate auto cine review.
- Reviewing speed: in auto cine review status, click [Auto Play] on the soft menu to adjust the review speed. When the speed is changed to 0, the system exits auto cine review.
- In auto play status, set [Auto Play] to "Stop" or roll the trackball to exit auto play.

● Setting the Auto Review Region

You can set a segment of cine loop which can be reviewed automatically. After the auto review region is set, the auto cine review can only be performed within this region; but the manual cine review can be performed beyond this region. When the cine file is saved, only the images within this region are saved.

- Set first frame: Manually review the images until the frame which you want to set it as start point, and then click [Set Begin] to set it as the start point.
- Set end frame: Manually review the images until the frame which you want to set it as end point, and then click [Set End] to set it as the end point.
- Use the soft menu control to click [Auto Play] to set the value, then the system enters the auto cine status, and use this control to adjust speed.
- Click [Auto Play] again or roll the trackball to enter manual review status.
- Click [Jump to First]/ [Jump to Last] to review the first or last image.
- Click [Save Cine] in the soft menu to save the cine images of the set region.

Tip: you can perform cine review on each image window in the dual/quad splitting mode, and set the auto review region for each window.

6.4.3 Cine Review in M/PW/CW/TVD Mode

Enter cine review in M/PW/CW/TVD mode and roll the trackball. The cine images are displayed on the screen one by one.

Roll the trackball to the left. The review progress slider moves to the left, the images move to the right and the earlier stored images are displayed. Or, roll the trackball to the right. The review progress slider moves to the right, the images move to the left and the recently stored images are displayed. When you review images to the first or last frame, rolling the trackball further will display the last or first frame.

The cine progress bar at the bottom of the screen (as shown in the figure below):

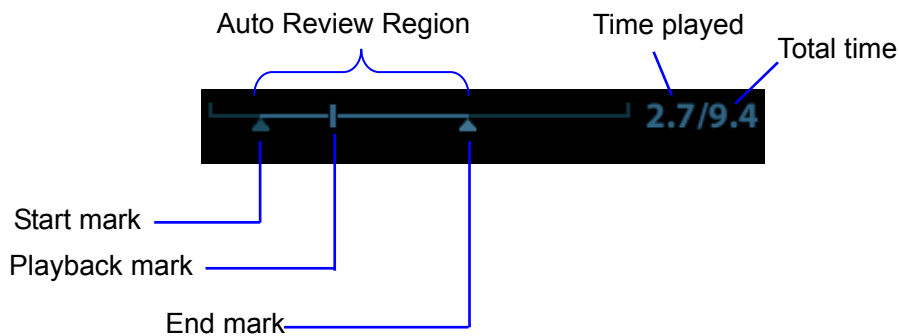

Cine review operations are the same as those in 2D mode.

6.4.4 Linked Cine Review

Linked cine review reviews images captured at the same moment.

- Dual live mode (B/Color/Power/TVI/TEI)
- B+M
- B/B Dual liveDuplex mode (B+PW/CW/TVD)
- Triplex mode, TVM or CM mode

Frame synchronization mark

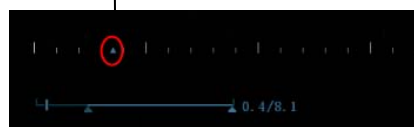



Playback progress bar

The frame mark on the time mark of the M/PW image indicates the corresponding 2D image. In statuses other than dual live status, you can only review images in the currently active window.

6.5 Image Compare

6.5.1 Image Compare

You can perform image compare through the path:

- Thumbnail area in the main screen;
 - iStation screen (press <iStation> to enter);
 - Review screen (press <Review> to enter).
1. In the above condition, press <Cursor> to show the cursor and click the target image file.
 2. 3 buttons will appear to the right of the image, click  to select the image for comparison marked by .

If the wrong image has been chosen, click  to cancel the selection of this image.

Tip: for B/B+COLOR/B+TVI/B+POWER/B+TEI mode image, you can select at most 4 images; for PW/M/CW/TVD/contrast single/ Elasto single mode image, you can select at most 2 images.

3. Repeat the above steps to add other image files for comparison.
4. Click [Image Compare] (click  in thumbnail status) to enter image compare mode.
5. Review images from different image windows. Press the <Dual> or <Quad> key to switch the active image window.

The window with the highlighted “M9” mark is the currently activated window.

6. Save the image if necessary.
7. Click [Return] on the screen or press <Freeze> to exit image compare.

Image compare of different exams for the same patient:

- a) Select different exams in the iStation screen, then select [Review Image] in the menu which appears to enter the Review screen.
- b) In the Review screen, click [Exam History] to select the exam. Click to select the image to be compared in different exams, and click [Compare].

You can select if cine files are synchronously replayed by the soft menu control: select [PlayMode: XX] to [SyncPlay] to play all files synchronously or [ASyncPlay] to play asynchronously.

6.5.2 Frame Compare

1. Freeze the image in B/C mode. Click [Frame Compare] on the soft menu to enter frame compare mode.
2. Review the images of different image windows (cine replaying cannot be performed for single-frame image files). Press the <Update> or <Dual> key to switch the active image window (current active window is marked by a highlighted “M9”).

3. Save the image if necessary.

Measurements and adding comments and body marks are allowed.

4. Click [Frame Compare] again to return to image frozen status. Press <Freeze> to enter real-time imaging.

Tip: Cine compare can only be performed on single-format 2D images.

6.6 Cine Saving

■ Live capture

Live capture refers to saving the images or cines in image scanning status. After storing them, the system continues with image scanning.

Live capture can be divided into two types: retrospective and prospective.

- Retrospective saving saves specified images which were captured before the current moment. Images stored in the cine memory are saved to the system's hard drive.
- Prospective saving saves specified images which are captured later than the current moment. Images are saved to both the cine memory and the system's hard drive.

The live capture time can be set.

To perform live capture:

- In imaging mode, press the <Save> key on the control panel (the key has already been assigned the function “Save Clip (Prospective) to hard disk” or “Save Clip (Retrospective) to hard disk”).
- Click [Pro Capture] or [Retro Capture] on the soft menu in contrast real-time mode.

Tip:

- Press the save key again or <Freeze> to stop saving.
- When saving is complete, a thumbnail displays in the Thumbnail area.

■ Frozen image storage

In frozen mode, press the <Save 2> key on the control panel (the key has already been assigned the function “Save Clip (Retrospective) to hard disk”).

After the cine is successfully saved, a thumbnail is displayed on the screen.

The live capture time can be set.

6.7 Preset

6.7.1 Setting Cine Length

Open [Setup] → [System Preset] → "General" to perform the following settings:

- Non-live storage

Clip Length	
Time(s)	<input type="text" value="5.0"/>
Beat(heart cycle)	<input type="text" value="5"/> ▼

- Live capture
 - Type: Retrospective, Prospective.
 - Cine length:

Prospective Cine Length	
Time(s)	<input type="text" value="180"/> (1-480s)
Beat(heart cycle)	<input type="text" value="120"/> (1-390 Cycles)
Retrospective Cine Length	
Time(s)	<input type="text" value="6"/> (1-120s)
Beat(heart cycle)	<input type="text" value="120"/> (1-120 Cycles)

Tip: If the value is out of range, the system can change it to the nearest effective value.

7 Physiological Signal

The scanned image displayed is synchronized with the ECG respiratory waves. Those signals can be used as a time reference in an ultrasound exam (mainly in cardiology exams).

The ECG function is an option.

⚠ WARNING: DO NOT use the physiological traces for diagnosis and monitoring.

To avoid electric shock, the following checks must be performed prior to an operation:

The ECG electrode cable must not be cracked, frayed or show any signs of damage or strain.

The ECG electrode cable must be correctly connected.

You must use the ECG leads provided with the physiological module. Failure to do so may result in electric shock.

The ECG electrode cable must be connected to the system first. Only after the cable is connected to the system can the patient be connected to the ECG electrodes. Failure to follow these instructions can subject the patient to electric shock.

DO NOT place the ECG electrodes directly in contact with the patient's heart. This can stop the patient's heartbeat.

DO NOT apply the ECG electrodes if the voltage exceeds 15 volts. This could result in an electric shock.

Before using the high-frequency electric surgical unit, high-frequency therapeutic equipment or defibrillator, be sure to remove the ECG electrode from the patient in order to prevent electric shock.

Conductive parts of electrodes and associated connectors for ECG must not come into contact with other conductive parts including earth/grounding.

Frequent trampling on or squeezing of the cables may result in cable failure or fracture.

Display effect of respiratory curve depends on the patient breathing status. While a very slow or smooth breathing may lead to an inapparent respiratory curve, breathing in a large amplitude may cause an incomplete display of the respiratory curve. Display effect is linked to the connected parts of the body. Generally, signals by connecting to limbs are stronger than by connecting to the chest.

If an abnormality is detected in physio trace, check that the ECG leads are properly connected to the system.

7.1 ECG

7.1.1 ECG Operation Basic Procedures

1. Connect the device.

- Turn off the system power supply, and connect the ECG cable to the ECG port on the left side of the machine.
- Turn on the system power supply.

Place the ECG electrodes on the patient's body (as shown in the following figures).

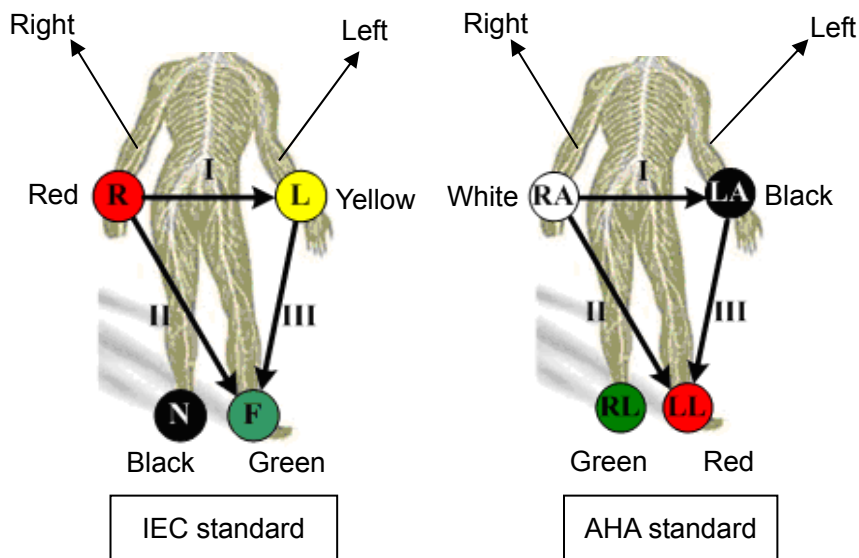

2. Press the <Physio> key on the control panel to enter physio operation status.
3. Switch the imaging modes and display formats. Adjust the parameters to obtain an optimized image.
4. Parameter adjustment:
- Use <Switch Mode> key to switch to Physio mode soft menu.
 - On the Physio page, click [ECG] on the menu in the top-left corner of the screen to show/hide the ECG trace.
 - Adjust the [Speed], [ECG Gain], [Position] and [Invert].
5. Trigger:
- Select the trigger mode, or switch on [Real & Trig], set the trigger time.
6. Freeze the images and review the images.
7. Press <Physio> to exit ECG mode, and remove the ECG electrodes from the patient.

7.1.2 ECG Triggering

7.1.2.1 Overview

ECG triggering means that image scanning is activated at some time points of ECG signals, thus obtaining B images at these time points. In most cases, the triggered images are 2D-mode images.

When ECG triggering occurs, a mark appears on the ECG waveform, indicating the time points when the B images are captured (corresponding to the delay time from R curve started).

Tips:

- The trigger mark is displayed in both freeze mode and live mode.
- The marks in Dual trigger are different in color.
- Trigger function is unavailable if the ECG trace is disappeared. Only the live 2D image can be triggered.
- No delay time or time interval shall less than the time required to scan a single image.
- If the delay time is longer than a heart cycle, then the heart cycle between the delay time is omitted, that is to say no trigger is occurred when R waveform is detected in the duration.

7.1.2.2 Triggering Mode

There are three triggering modes available: Single, Dual and Timer.

- Single Trigger: when an R waveform is detected, an image will be triggered after delay time T1. The value of T1 can be changed in triggering status.
- Dual Trigger: when an R waveform is detected, the image will be triggered respectively after delay time T1 and T2. The value of T1 and T2 can be changed in triggering status.
- Timer Trigger: an image will be triggered after a certain interval. The time interval can be changed in triggering status.

The image trigger operation is described as follows (Take single trigger as an example):

1. Select exam mode.
2. Click [Trig Mode] on the soft menu to enable the trigger.
3. Select [Single].
4. Set the delay time on the soft menu according to actual situation.

7.1.2.3 Real & Trigger

Click [Real & Trigger] on the soft menu to enable or disable the real trigger function.

After the [Real & Trigger] is turned on, two images are displayed respectively in two windows, one is triggered by ECG, and the other is non-triggered real time image.

7.2 Respiratory Wave

7.2.1 Respiratory Wave Operation Basic Procedures

1. Connect the ECG lead and position the ECG electrodes. For details of ECG lead connection, see “7.1.1 ECG Operation Basic Procedures”.
2. Press <Physio> on the control panel to enter Physio screen.
3. Switch the imaging modes and display formats, adjusting the parameters to get an optimized image.
4. Parameter adjusting

Use <Switch Mode> key to switch soft menu and top-left menu to be physio menu. In Physio menu, click [RESP] in the top-left part of the screen and switch respiratory curve display to be ON. Adjust [Speed], [RESP Gain], [RESP Position] and [Invert].

5. Exit Respiratory display mode, and remove ECG electrodes from the patient.
6. Press <Physio> to exit physio mode.

7.3 Parameter Description

The physio parameters are described as follows:

Parameter	Description
ECG Source	Select ECG source.
Gain	Function: to set the amplitude of the trace. Method: click [Gain] on the soft menu, or press/rotate the corresponding knob. Each adjustment takes you to the next setting. Value: 0-30, in increments of 1.
Position	Function: to set the vertical position of the both traces on the image display. Method: click [Position] on the soft menu. Each adjustment cycles you to the next setting. Value: 0%-100%, in increments of 5%.
Speed	Function: change the speed of the physio trace. Value: 10-90mm/s.
T1	Function: to set the delay time T1 in Single trigger or Dual trigger.
T2	Function: to set the delay time T2. Method: select a proper value in the drop-down list.
Interval	Function: to set the time interval for Timer. Method: select a proper value.
Invert	To invert the display.

8 Measurement

You can perform measurements on zoomed images, cine reviewing images, real-time images or frozen images. For measurement details, see the [Advanced Volume].

 **WARNING:** Be sure to measure areas of interest from the most optimal image plane to avoid misdiagnosis arising from inaccurate measurement values.

To obtain accurate Doppler flow measurement values, make sure the transmitting beam is not perpendicular to the flow as this may lead to false readings and potential misdiagnosis.

 **CAUTION:** If an image is unfrozen or the mode is changed during a measurement, the calipers and measurement data will be cleared from the screen. Measurement data will be stored in the report.

If the system is turned off or <End Exam> is pressed during a measurement, unsaved data will be lost.

In dual-B imaging mode, the measurement results of the merged image can be inaccurate. Therefore, the results are provided for reference only, not for confirming diagnoses.

You can create user-defined measurement tools using the UltraAssist tool and then import them into the ultrasound system to carry out specific measurements.

For details about this feature, see the UltraAssist manual.

8.1 Basic Operations

■ To enter/exit measurement

To enter: press <Caliper> on the control panel to enter general measurement. Press the <Measure> key to enter application measurement.

To exit: press the <Caliper> key or the <Measure> key again.

■ Measurement results and help information

The system displays and updates measurement results in the results window.

The help information concerning measurement and calculation is displayed in the Help Information area at the bottom of the screen.

8.2 General Measurements

8.2.1 2D General Measurements

2D general measurements are general measurements on images in B, Color, Power or iScan imaging modes. The measurements listed below can be performed:

Measurement Tools	Function
Distance	Measures the distance between two points of interest.
Depth	Measures the distance between the probe surface and the probing point along the ultrasound beam.
Angle	Measures the angle between two intersecting planes.
Area	Measures the area and perimeter of a closed region.
Volume	Measures the volume of a target.
Double Dist.	Measures the length of two line segments which are perpendicular to each other.
Parallel	Measures the distances between each pair of parallel lines in a sequence.
Trace Length	Measures the length of a curve.
Distance Ratio	Measures the lengths of any two lines and calculates the ratio.
Area Ratio	Measures the areas of any two regions and calculates the ratio.
B histogram	Measures the grayscale distribution of ultrasonic echo signals in a closed region.
B profile	Measures the grayscale distribution of ultrasonic echo signals across a line.
Color Velocity	Measures the color flow-velocity (only in Color mode).
Volume Flow	Measures the blood flow through a vascular cross section per unit time.
Strain Ratio	Measures the strain ratio in the image.
Strain-Hist	Displays the strain ratio using the histogram.

8.2.2 M General Measurements

M general measurements are general measurements on M-mode, CM-mode and AM-mode images. The measurements listed below can be performed:

Measurement Tools	Function
Distance	Measures the vertical distance between two points.
Time	Measures the time interval between any two points.
Slope	Measures the distance and time between two points and calculates the slope.
HR	Measures the time of n ($n \leq 8$) cardiac cycles and calculates the heart rate in M mode images.
Velocity	Calculates the average velocity by measuring the distance and time between two points.

8.2.3 Doppler General Measurements

Doppler general measurements are general measurements on PW/CW-mode images. The measurements listed below can be performed:

Measurement Tools	Function
Time	Measures the time interval between any two points.
HR	N intervals ($n \leq 8$) are measured to calculate a PW mode derived HR value in Beats Per Minute (BPM).
D Velocity	On Doppler mode images, velocity and PG (pressure gradient) of a point on the Doppler spectrum waveform are measured.
Acceleration	The velocity and time interval between two points are measured to calculate the speed difference and acceleration.
D Trace	On PW mode images, one or several Doppler waveforms are traced to obtain the speed and PG, etc.
PS/ED	Velocity and PG between two peaks on the Doppler spectrum are measured to calculate the RI (resistance index) and PS/ED (peak systolic/end diastolic).
Volume Flow	Measures the blood flow through a vascular cross section per unit time.
Ratio (Vel.)	Measures the D velocity and calculates the ratio value for blood analysis.
Ratio (VTI)	Measures the VTI values from the spectrum and then calculates the ratio value.

8.3 Application Measurements

- Abdomen measurements - used for measuring abdominal organs (liver, gall bladder, pancreas and kidney, etc.) and large abdominal vessels.
- OB measurements - used for measuring fetal growth indices (including EFW) as well as GA and EDD calculations. The fetus can be evaluated through growth graph analysis and the fetal biophysical profile.
- Cardiac measurements - used for left ventricle function measurements and measuring main artery and vein parameters, etc.
- Gynecology measurements - used for the uterus, ovary and follicles, etc.
- Small Part measurements - used for small parts such as the thyroid.
- Urology measurements - used for the prostate, seminal vesicle, renal, adrenal, micturated and testicular volume.
- Pediatrics measurements - used for hip joint measurement.
- Vascular measurements - used for carotid, cerebral, upper and lower extremities vessels, etc.
- EM measurements - used for EM-related full functional measurements.

8.4 Measurement Accuracy

Table 1 Basic Dimension Measurements

Parameter	Range	Error
Distance	Full Screen	Within $\pm 3\%$
Area (ellipse, circle)	Full Screen	Within $\pm 7\%$
Trace Area	Full Screen	Within $\pm 7\%$
Circ	Full Screen	Within $\pm 10\%$
Angle	Full Screen	Within $\pm 3\%$
Volume	Full Screen	Within $\pm 10\%$

Table 2 Basic Time Motion Measurements

Parameter	Range	Error
Distance	Full Screen	Within $\pm 3\%$
Time	Timeline Display	Within $\pm 2\%$
Heart Rate	Timeline Display	Within $\pm 4\%$
Velocity (PW mode)	10-200cm/s (for C5-1s, C11-3s, V11-3Ws, L12-4s, L14-6Ns) 10-300cm/s (for P10-4s, P7-3Ts, SP5-1s)	When angle $\leq 60^\circ$, $\leq 5\%$.
Velocity (CW mode)	10-300cm/s (for P10-4s, P7-3Ts, SP5-1s)	When angle $\leq 60^\circ$, $\leq 5\%$. (not including pencil probe)

Table 3 iScape measurements

Parameter	Range	Error
Distance	Full Screen	Within $\pm 5\%$ (not including C11-3s and V11-3Ws)
		Within $\pm 10\%$ (for C11-3s and V11-3Ws only)

NOTE: Within the selected field range, measurement accuracy is ensured within the range mentioned above. The accuracy specifications are performed in the worst conditions, or based on real system tests, regardless of acoustic speed error.

9 Comments and Body Marks

9.1 Comments



Comments can be added to an ultrasound image to bring attention, notate or communicate information observed during the examination. You can add comments to: zoomed images, cine review images, real-time images, frozen images. You can type comments as characters, insert pre-defined comments from the comments library or insert arrow markers.

 **WARNING:** Ensure that the entered comments (body marks) are correct. Incorrect comments may lead to misdiagnosis!

9.1.1 Comments Basic Procedures

To enter a comment:

1. Enter comment status:

- Press , or,
- Press any alphanumeric key or the space bar to enter comment status, or,
- Press  to enter arrow-adding status.

2. Position the cursor over the desired location for the comment,

3. Add a new comment to the image in accordance with the actual situation. You can modify, move or delete a completed comment.

4. To exit comment status:

- In comment status, press , or
- In arrow-adding status, press , or,
- Press <ESC> or other operating mode keys to exit.

9.1.2 Soft Menu Display in Comments

The system can be configured with comment text libraries including Abdomen, Cardiology, GYN (Gynecology), OB (Obstetrics), Urology, SMP (Small Part), Vascular, PED (Pediatric), Nerve Blocks and emergency medicine. In comments status, you can enter the comment text using the screen menu.

- To set the comment home location.
Roll the trackball to move the cursor to the desired comment location and press <Set Home> on the keyboard area on the control panel.
- Return the cursor to the set home location.
Press <Home> on the control panel to return the cursor to the set home location.
- Navigate through the comment libraries
To select the comment library, click [Library] on the soft menu to select (available libraries are linked to the exam modes configured for the current probe).
- Add/modify comment positions
Click [RT/LT] or [Sag/XS] to directly mark the position. Move the cursor onto the comment item to be modified, click [RT/LT] or [Sag/XS] to change the already-added comment position.
- Change Font Size/Arrow Size
To change the font size of next input comment text, use [Font Size] button on the soft menu to select from Small, Medium and Large.
To change the arrow size, use [Arrow Size] button on the soft menu to select from Small, Medium and Large.
- Comment display/hide
Select[Hide]/[Display] on the soft menu to display or hide the comments.
- Trace
Click [Trace] on the soft menu to enter trace commenting status.

9.1.3 Adding Comments

■ Typing comment characters

1. To set the comment location:

Roll the trackball or press the direction keys on the keyboard to move the cursor to the desired comment location.

2. To type alphanumeric characters:

- Type alphanumeric characters using the qwerty or soft keyboard (characters are uppercase by default).
- In edit status (the characters are green in color), press <Enter> to move the cursor to the new line. The cursor is aligned with the first line.

3. In edit status, press <Set> or <Enter> on the control panel to confirm the added character. The color of the added character turns to yellow.

■ Adding a Comment Text

In comment status:

1. Roll the trackball to move the cursor over the desired comment text on the screen menu and press <Set>.
2. The system adds the selected comment text to the screen (in current status, the comment is in green, which means you can continue editing the comment).
3. Press the <Set> or <Enter> key, or roll the trackball to confirm the added comment text and exit the edit status. The comment changes to yellow.

■ Adding an arrow

You can add an arrow to a location you want to highlight.

To add an arrow:

(1) Press the <Arrow> key and an arrow will appear in the default position.

(2) Adjust the shape and position of the arrow:

- To position the arrow on the area of interest and change the orientation: roll the trackball to the desired position as well as change the orientation of the arrow.
- To slightly change the orientation of the arrow: rotate the <Angle> knob to change the arrow's orientation (in increments of 15°).
- Adjust the arrow size: rotate the knob under the [Arrow Size] button on the soft menu to change the size.

(3) Press <Set> or <Enter> to anchor the arrow's position. The arrow turns yellow. Repeat the above steps to add more arrows.

(4) Press <Arrow> on the control panel to exit arrow comment status.

■ Tracing

(1) In comment status, click [Trace] on the soft menu to activate the trace function.

(2) Control Panel operation:

- a) Roll the trackball to the desired position and press <Set> to confirm the start point.
- b) Roll the trackball to move the cursor along the edge of the desired region and trace the outline of the region.
 - Rotate the <Angle> knob counter-clockwise to cancel 1 pixel of trace.
 - Rotate the <Angle> knob clockwise to restore 1 pixel of trace.
 - Press <Clear> to delete tracing.
- c) Press <Set> to finish tracing.

9.1.4 Moving Comments

1. Select the comment to be moved.
2. Roll the trackball to move the comment to a new position.
3. Press the <Set> key to anchor the comment in the new position.

9.1.5 Modifying (Editing) Comments

■ Modifying (Editing) characters

1. In comment status, move the cursor over the comments to be modified.
 - Press the alphabetic keys to enter the character at the cursor position.
 - Or, double press <Set> to enter comment editing status and use the direction keys to move the cursor to the desired location to insert/delete characters. Either type characters by pressing the corresponding keys or select the new comment text from the menu.
2. Press to delete the comment character or text on the right side of the cursor. Press <Backspace> to delete the comment character or text on the left side of the cursor.
3. Roll the trackball or press <Set> to confirm the modification and exit the edit status. The comment turns to yellow.

■ Under non-comment status, if there are already comments on the screen, press the space bar to enter editing status.

■ Modifying (Editing) Arrows

1. Move the cursor over the arrow that needs to be modified. After the cursor turns to , press the <Set> key. The current arrow turns green, and there is a green frame around the arrow indicating that the arrow can be edited. Move the cursor to change the arrow's position.
2. Rotate the <Angle> knob to modify the arrow's direction.
3. Press the <Set> or <Enter> key to complete the operation.

9.1.6 Deleting Comments

■ Deleting Comment Characters, Texts or Arrows

1. Move the cursor to the comment to be deleted.
2. Press the <Set> key to select the comment.
3. Press <Backspace>, or <Clear> key to delete the comment.

■ Deleting a recently-added character, text or arrow

After adding several comments and the cursor is in “|” or “↔” status, press <Clear> to delete recently-added or recently-edited comments.

■ Delete All Comments

Long press <Clear> to delete all the comments.

NOTE: When no object is selected, long pressing the <Clear> key will clear all comments and all measurement calipers.

After powering off, the system will clear all comments on the image.

9.1.7 Comment Setting

■ Comment Text Setting

1. In comment status, click [Custom] on the soft menu to enter the user-defined comment screen.



- Add new comment texts: position the cursor in the box above [Add Comment] and enter the text comment using the keyboard. Then click [Add Comment]. The directly-entered comment will be added to the current comment text library.
2. Click [Save] to save the settings and exit the screen. Click [Cancel] to exit the screen without making any changes.

■ Comment Setting

Enter the “[Setup] → [System Preset] → [Application]” screen to perform the following setting:

- You can preset whether to clear the comments when unfreezing the image or changing the probe/exam.
- Set whether body marks are erased when the image is unfrozen.

9.2 Body Mark

NOTE: After powering off, the system will clear all comments on the image.

The Body Mark (Pictogram) feature is used to indicate the patient's position during the exam as well as the transducer position and orientation.

The system supports body marks for Abdomen, Cardiology, GYN, OB, Urology, Small Part and Vascular applications. In addition, the system supports importing user-defined body marks.

9.2.1 Soft Menu Display in Body Mark

The body mark soft menu displays the settings for the current mode:

- Library

Use [Library] on the soft menu to switch the body mark library. Corresponding body marks are shown on the left (available libraries are linked to the exam modes configured for the current probe).

- User-defined body mark

Click [Custom] to enter the dialog. You can import body mark graphs here.

You can import a user-defined body mark in BMP/PNG format of 140*140 (unit: pixel) in size.

- Save Probe

If the probe mark direction and position is determined for the current body mark being added, click [Save Probe] to save the current probe mark direction and position for the body mark.

9.2.2 Adding Body Marks

1. Enter Body Mark status. Use the knob under [Library] to select the body mark category.
2. Adding Body Marks: move the cursor over the desired body mark to highlight your choice. Press <Set> to add the body mark, and the body mark is highlighted in green solid frame at the bottom-left of the image.
3. To adjust the probe position and orientation marker:
 - Roll the trackball to position the probe marker.
 - Rotate the <Angle> knob to adjust the orientation.
 - Click [Save Probe] to save the current probe mark direction and position for the body mark.
4. Press <Set> to confirm the position and orientation of the probe marker and exit Body Mark mode.

9.2.3 Moving Body Marks

You can move the body mark graphics to any desired position within the image area.

1. Press <Cursor> and roll the trackball to move the cursor over the body mark. The cursor then changes to , indicating you can move the pictogram to a new position.
2. Press the <Set> key to select the body mark.
3. Roll the trackball to move the Body Mark graphic to the desired position.
4. Press <Set> to anchor and confirm the graphic's new position.

NOTE: In Dual-split mode, a body mark cannot be moved between the separate image windows.

9.2.4 Deleting Body Marks

1. Use the trackball to position the cursor over the body mark graphic and press <Set> to select.
2. Press <Clear> to delete the selected body mark.

NOTE: If no object is selected, long pressing the [Clear] key will clear all comments, body marks and general measurements from the screen.

9.2.5 Body Mark Setting

Exit Setup page or changing the exam/patient/mode/probe will clear the body marks.

10 Patient Data Management

An exam record consists of all the information and data for one exam.

An exam record consists of the following information:

- Patient basic information and exam data
- Image files
- Report

NOTE: DO NOT use the internal hard drive for long-term image storage. Daily backup is recommended. External storage media is recommended for archiving images.

The system's patient database space is limited. Back up or clear patient data regularly.

Mindray is not responsible for lost data if you DO NOT follow the recommended backup procedures.

10.1 Patient Information Management

10.1.1 Enter Patient Information

General patient information and exam information are entered using the Patient Info screen. For details, see “4.1 Patient Information.”

10.2 Image File Management

You can store image files either in the patient database in the system, or to external memory devices. For a saved image, you can perform operations such as reviewing, analyzing and demonstrating images (iVision).

10.2.1 Memory Media

The system supports memory media including:

- System hard disk
- USB memory devices: USB flash drive, removable USB hard disk
- DVD+R, DVD+RW, DVD-R, DVD-RW, CD-RW, CD-R

10.2.2 Image File Formats

The system supports two types of image file formats: system-relevant and PC-compatible.

■ System-relevant formats:

- Single-frame image file (FRM)
Refers to single-frame static image files which cannot be compressed. You can add measurements and comments on this type of file.
- Cine file (CIN)
System-defined multi-frame file format. You can perform manual or auto cine review, and perform measurements or add comments for the reviewed images. After you open a stored CIN file, the system automatically enters cine review status.

The system can save FRM files as BMP, JPG, TIFF or DCM files, or save CIN files as AVI or DCM files by Send To function in iStation screen. For details, please refer to “10.2.12 Sending Image Files” chapter.

- PC-compatible formats:
 - Screen file (BMP)
Single-frame file format, used to save the current screen, non-compressed format.
 - JPG: single frame export format.
 - TIFF: single frame export format.
 - Multi-medium file (AVI)
Multi-frame export format.
 - DICOM file (DCM)
DICOM standard file format, single-frame or multi-frame format, used to record patient information and images, you can only open DCM files to view rather than to edit.

10.2.3 Image Storage Preset

- Set image size

You can set the image size via “[Setup] → [System Preset] → [General]”:



- Set cine saving length (clip length)
For details, see “6.7 Preset.”
- Set send/print image after ending the exam

Open “[Setup] → [System Preset] → General]”, check “Sending/printing after Ending Exam” in the Patient Management area. Then every time you press <End Exam>, the system will send images of the exam to the connected default DICOM server.

10.2.4 Quickly Saving Images to the System

- To save a single-frame image to the system quickly:

1. Set the user-defined key via the path: [Setup] → [System Preset] → [Key Config]. Select a key in the Key Function field on the left side, and select “Save Image” in the Output page of the Function field on the right side.
2. Press the user-defined key to save the image.
 - In the image screen, press the user-defined key to save the current single-frame image. The image is saved with the default filename in the default file directory in FRM format.
 - The image thumbnail will appear in the thumbnail area on the right side of the screen. When you move the cursor over the thumbnail, its filename and suffix will be displayed.
 - When a dialog box is displayed on the current screen, press the user-defined key to save the screen in BMP format.

- To save a cineloop image to the system quickly:

1. Set the user-defined key via the path: [Setup] → [System Preset] → [Key Config]. Select a key in the Key Function field on the left side, and select “Save Clip (Retrospective)” or “Save Clip (Prospective)” in the Output page of the Function field on the right side.
2. Press the user-defined key to save the cine file in the default file directory in CIN format.
The image thumbnail will appear in the thumbnail area on the right side of the screen. When you move the cursor over the thumbnail, its filename and suffix will be displayed.

You can set the clip saving length in the path: [Setup] → [System Preset] → [General].

10.2.5 Quickly Saving Full Screen Images to the System

1. Set the user-defined key via the path: [Setup] → [System Preset] → [Key Config]. Select a key in the Key Function field on the left side, and select “Save Screen” in the Output page of the Function field on the right side.
2. Press the user-defined key to save the image.
 - In the image screen, press the user-defined shortcut key to save the current screen image. The image is saved with the default filename in the default file directory in BMP format. The image thumbnail will appear in the thumbnail area on the right side of the screen. When you move the cursor over the thumbnail, its filename and suffix will be displayed.

10.2.6 Quickly Saving Images to USB Flash Drive

Use the user-defined key to quickly save the single-frame to USB flash drive.

The image file is stored in the directory: patient name + ID\exam type + exam time\image ID.

1. Set the user-defined key via the path: [Setup] → [System Preset] → [Key Config].
Select a key in the Key Function field on the left side, and select “Save Image to USB disk” in the Output page of the Function field on the right side. Click [Save] to exit setup.
2. Press the user-defined key to save the image to the USB flash drive.

10.2.7 Quickly Exporting Cine File to USB Flash Drive

Use the user-defined key to quickly save the cine file to USB flash Drive directly (without saving to the hard disk).

The file is stored in the directory: X (USB flash drive name): patient name+ ID\exam type + exam time \ image ID.

1. Set the user-defined key through the path: [Setup]→ [System Preset]→ “Key Config”. Select a key in the Key Function page on the left side and select “Send Cine to USB disk” in the Output page of Function field on the right side. Click [Save] to exit preset page.
2. Scan and freeze the image
3. Press the user-defined key to save the cine to the USB flash drive.

10.2.8 Auxiliary Output Function

For the following three functions, the system provides auxiliary output function setting: “Save Image”, “Save Clip(Retrospective)” and “Save Clip(Prospective)”.When the corresponding user-defined key is pressed, the ultrasound system can perform multiple operations one by one as per the preset.

- Save Image
 - Send Image to DICOM Storage
 - Send Image to DICOM Printer
 - Save Image to USB disk
 - Send Image to iStorage
 - Send Image to Local Default Printer
- Save Clip (Retrospective)/(Prospective):
 - Send Cine to DICOM Storage
 - Send Cine to USB disk
 - Send Cine to iStorage



Setting method (take “Save Image” as an example, add the auxiliary functions “Send Image to DICOM Storage” and “Send Image to USB disk”):

1. Set the user-defined key through the path: [Setup]→ [System Preset]→ [Key Config]. Select a key in the Key Function field on the left side and select “Save Image” in the Output page of Function field on the right side.
2. Click [Add] in the middle part of the screen, then there will be “Function2: NULL” under the key function in the Key Function Field on the left side, and at the same time, “Output” column on the right side will show the available auxiliary functions for current key. Select “Send Image to DICOM Storage” in the “Output” column on the right side. Then the Function2 on the left side turns into “Send Image to DICOM Storage”.
3. Click [Add] again, then there will be “Function3: NULL” under the key function in the Key Function Field on the left side. Select “Send Image to USB disk” in the “Output” column on the right side. Then the Function 3 on the left side turns into “Send Image to USB disk”.
4. Click [Save] to confirm.
5. Scan and freeze the image
6. Press the user-defined key, then the system will perform three steps: 1. Save the image to the local hard disk; 2. Send image to DICOM Storage server; 3. Send the image to USB disk.

Tips: repeat step 3 will continue adding auxiliary functions, you can add 6 functions at most.

10.2.9 Thumbnails

Stored images are displayed in the form of thumbnails on the screen:

- During image scanning, thumbnails of the current exam display in the right of the screen. Click  or  to change the display format.
- In the iStation screen, the thumbnails of the current selected patient display at the bottom of the screen. When you move the cursor over a thumbnail, its name and format display.
- In the Review screen, the thumbnails refer to the images stored in the same exam. When you move the cursor over a thumbnail, its name and format display.
- In the Review screen, open an image to enter the image analyzing status. All the thumbnails belonging to the exam will be displayed on the right.

10.2.10 Image Review and Analysis

You can review and analyze stored images (only refer to images stored in the system default path).

10.2.10.1 Review an Image

You can review all images stored in an exam, and send, delete or analyze the stored images.

- To enter image review:
 - During image scanning, saved image thumbnails display in the right part of the screen. Move the cursor over a thumbnail and press <Set> twice to open the image. If the stored image is a cine file, double-click the thumbnail to enter the auto cine review.
 - Press <Review> to enter the Review screen. Images of the current exam and the current patient are displayed.
 - Select a patient's exam in the iStation screen and press <Review> or double-click the exam to enter the Review screen to review the images of the patient.

The Review screen is shown as follows:

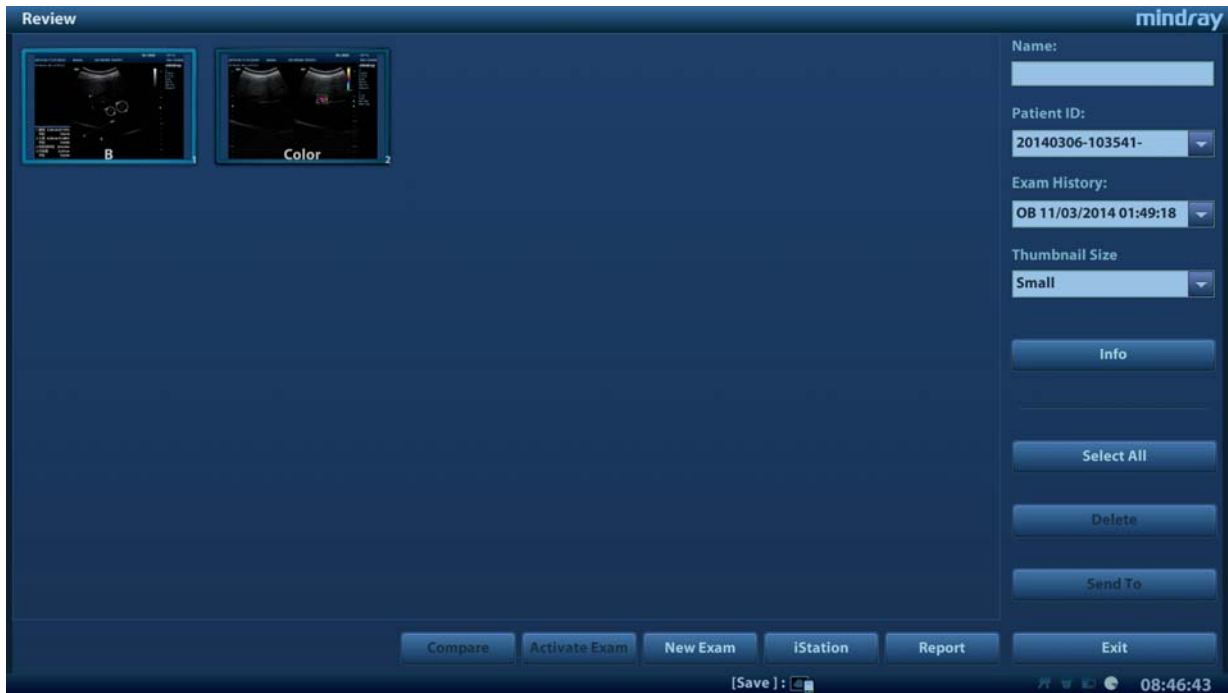

- To exit Review:
 - Click [Exit] on the Review screen
 - Press <ESC> or press <Review> again.

Functions in the Review screen:

- Exam History:

You can select more than one exams of one patient in iStation screen to check the patient exam history.
- Info

Click to enter the Patient Info screen, you can review or edit the currently-selected patient's information.
- Report

Click to review or edit the currently-selected patient's report.
- Image operations
 - [Select All]: click to select all images in the thumbnail window.
 - [Deselect All]: after clicking [Select All], the button changes to [Deselect All]. Cancel all selections by clicking [Deselect All].
 - [Send To]: click to send the selected image to another location, DICOM server, printer, etc. Or select the image and click the  icon at the top right of the image.
 - [Delete]: click to delete the selected image.
 - [Image Compare]: image compare function. For details, see “6.5 Image Compare” chapter.
- Thumbnail Size

To change the thumbnail size.
- Other operations:
 - [New Exam]: click to create a new exam for the selected patient and open the Patient Info screen.
 - [Activate Exam]: activate the currently-selected exam (already ended) and enter the image scanning screen.
 - [iStation]: click to enter the iStation screen.
 - [Exit]: click to exit Review status and return to the main screen.

10.2.10.2 Image Analysis

In image analysis status, you can view, zoom, perform post-processing and measurements, add comments and perform cine (multi-frame) review for a stored image. The operation steps are the same as those for real-time scanning. See the relevant sections for details.

- To enter image analysis:
 - In image scanning or freeze status, double-click a thumbnail stored in this exam to enter the image analysis status, or
 - In image review status, double-click the selected thumbnail to open the image.
- To exit image analysis:
 - Press <Freeze> to exit and enter real-time scanning status.
- Other operations

You can perform cine review operations in image analysis status. For details, see “6 Display & Cine Review.”

10.2.11 iVision

The iVision function is used to demonstrate the stored images. Image files are played one by one according to file names (including system-relevant and PC-compatible format images).

To perform image demonstration:

1. Enter the iVision screen:
Press the user-defined key for iVision (setting path: [Setup] → [System Preset] → [Key Config.])
2. Add the contents to be played and select demo mode.
3. Select an item in the list and click [Start] to begin the demonstration.
4. Click [Exit] or press <ESC> to exit iVision status.

The iVision screen is shown as follows:

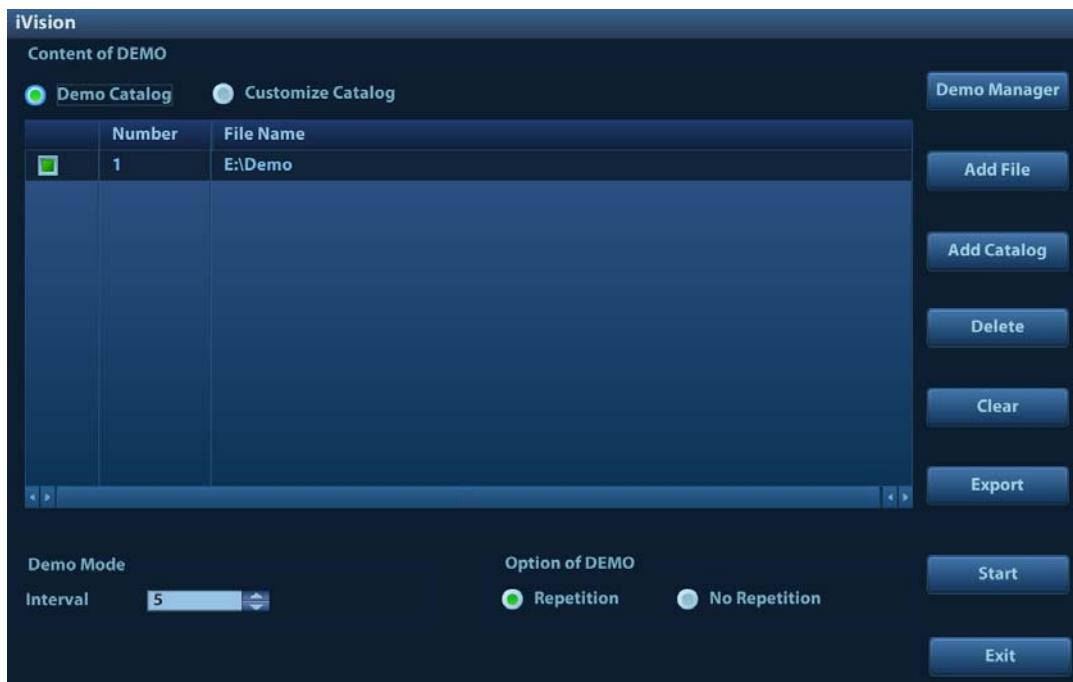

■ Demonstration item

Demonstration items are image files in formats supported by the system. You can add exam data from the patient database or system-supported image files and folders to the demonstration list. For files and folders in the demonstration list, the images in the directory and subdirectory are played one by one, and the system will automatically skip files that cannot be opened.

■ Demonstration catalog

There are two kinds of catalog: Demo Catalog and Customize Catalog.

- Demo Catalog: the demo catalog is a folder on the hard disk where the factory DEMO is stored. The system plays the images in this folder when performing demonstrations.

The system supports importing, deleting or clearing the data in the demo catalog.

Click [Demo Manager] to operate:

[>]: to import data into the demo catalog.

[<]: to delete selected data.

[<<]: to delete all data.

- Customize Catalog: the catalog of the displayed images is saved here. The system plays the images in the catalog when performing demonstrations.

Operate the catalog or the files using the buttons on the right:

[Add File]: to add files to the file list.

[Add Catalog]: to add a catalog of files to the list.

[Delete]: to delete selected files or catalogs from the file list.

[Clear]: to clear all the files or catalogs in the file list.

[Export]: to export selected directories/files to external storage devices. Click [Export] to bring up the Browse dialog box, select the path and click [OK].

■ Demonstration mode

The system automatically plays all the image files in the list one by one.



The time interval between images played is the same and can be changed.

■ Demo options

You can choose whether to repeat the demonstration or exit after a demonstration is complete.

10.2.12 Sending Image Files

NOTE: Data saved this way can only be reviewed on the PC and cannot be restored to the ultrasound system. See “10.4.2 Patient Data View & Management” chapter for details about data backup.

- On the image screen, select a stored image thumbnail and click  (Send To) in the top-right corner of the image. The image can be sent to the external device, DVD recorder, DICOM storage server, DICOM print server, system connected printer, etc.
- In the iStation screen, click , or, in the Review screen, click [Send To] to send patient data to an external memory device. You can also select on exam and click [Send To] to send all the image files of the exam. You can choose whether reports are exported with images. See the figure below.

See the figure below.

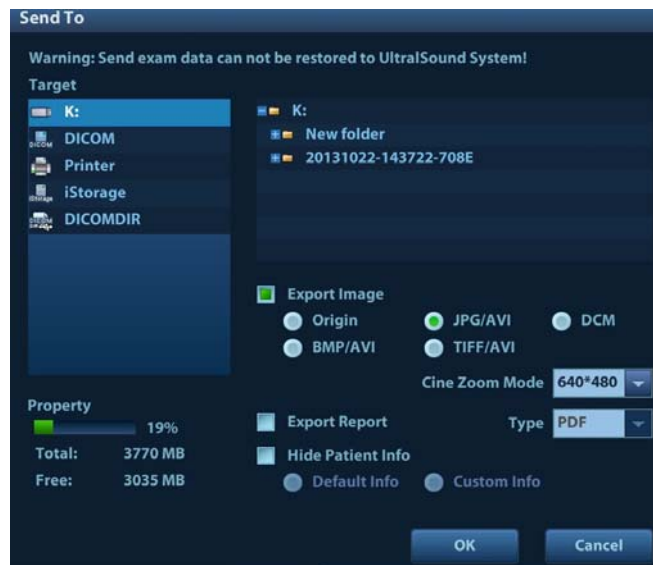

- For external memory devices (e.g., USB memory devices or DVD-RW) or iStorage:
 - a) PC format transfer: JPG/AVI, BMP/AVI, TIFF/AVI. Where a single-frame image is exported as JPG, TIFF or BMP, and the cine file is exported as AVI.
 - b) DCM format transfer: DCM (including single-frame DCM and multi-frame DCM).
 - c) Cine zoom mode can be changed.
 - d) You can also select whether to export reports and select the report type.
 - e) You can select if to hide patient information.
- For DICOM servers, select the DICOM Storage or Print server.

- For video printers, send images to the video printer connected to the system. For graph/text printers, send images to the default graph/text printer.

Note: if the transferred AVI file cannot be played normally on PC, please try to transfer the multi-frame cine file in MPEG format (set [Preset]->[General]->"AVI File Encode Format" to "MPEG" and try Send To function again) or use a VLC media player(<http://www.videolan.org/>).

10.3 Report Management

You can create user-defined report templates using the UltraAssist tool and then import them into the ultrasound system to carry out specific measurements.



For details about this feature, see the UltraAssist manual.

■ Report storage:

Exam reports are stored under the patient exam directory.

■ Importing, exporting and sending reports

- Import/export reports via Backup (in ultrasound system format)

In the iStation screen, select patient data, then click  or  in the menu which appears to import or export patient information, images and reports from or to an external memory device. See the following figure:

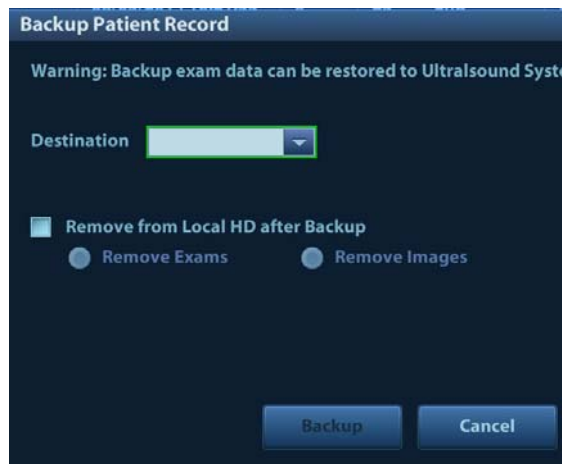

You can select the destination, and select whether to remove local data.

- Export reports via Send To (in PC format)

In the iStation or Review screen, click [Send Exam] in the menu which appears to send patient data to an external memory device or iStorage. You can choose whether reports are exported with images. See the figure below.

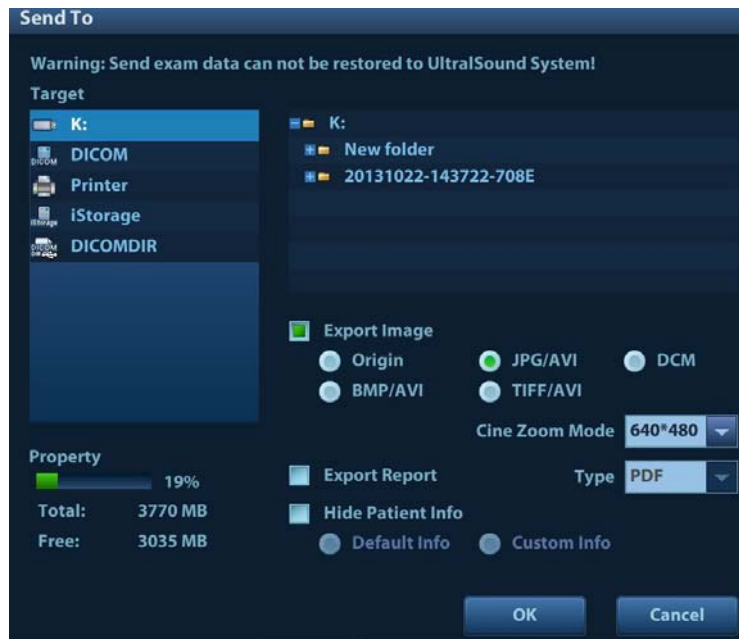

To export reports:

- (1) Check “Export Report” on the screen.
- (2) Select the report type to be exported.
- (3) Click [OK] to confirm.

You can select the paper size for the report print in the path: [Setup] → [Print Preset].

■ Report printing

Use a connected graph/text printer to print a report.

For details on report-related operations, see [Advanced Volume].

10.4 iStation - Patient Data Management

Patient data includes basic patient information, exam information, image files and reports. You can search, view, backup, send, restore or delete patient data in iStation.

- To Enter iStation
 - Press the <iStation> key on the control panel, or
 - Click [iStation] in the Patient Info screen, or
 - Click [iStation] in the Review screen.

The iStation screen is shown as follows:



10.4.1 Searching a Patient

1. Select the data source:
Click [Data Source]Select the patient data's data source; the system patient database is the default.
2. Set search conditions by Name, ID, DOB, Exam Date in the "Item" drop-down list.
3. Enter the keyword according to the "Item" selected. The system searches and displays the results in the patient list.
4. When you select a patient in the patient list, images of this patient will be displayed at the bottom of the screen.

10.4.2 Patient Data View & Management

Select the desired patient information in the list. The following menu appears:

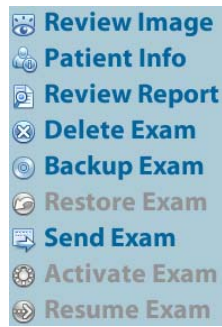

■ Review an Image

Select a patient exam, click [Review Image] to enter the Review screen.

■ Patient Information

Select a patient exam, click [Patient Info] to check the patient information for this exam.

■ Review Report

After selecting a patient exam, click [Review Report] to view the report of this exam for this patient.

■ Delete Exam

Select an exam record, click [Delete Exam] to delete the record. You cannot delete patient data which is being printed, exported or sent, or delete the current exam.

- To delete an image, select the image first and then click  on the top right side.

■ Backup/Restore

You can back up the selected patient data to the system-supported media in order to view it on the ultrasound system, or restore patient data to the system from an external media. For exams ended/paused within 24 hours, you can select to activate/continue the exam. For details, see “4 Exam Preparation” chapter.

- [Backup Exam]: click to back up the selected patient data to the system-supported media. You can select whether to remove images or the whole exam record from the system.
- [Restore Exam]: click to import patient data from an external media.

■ Send Exams

The system supports sending data to external memory devices, print or iStorage. You can use this function to export the exam data to external devices (in PC data or DICOMDIR data format) and then import to PC or restore to the ultrasound system to review the data.

1. Select the patient record, click [Send Exam] in the menu to send exam data and images of the selected record.

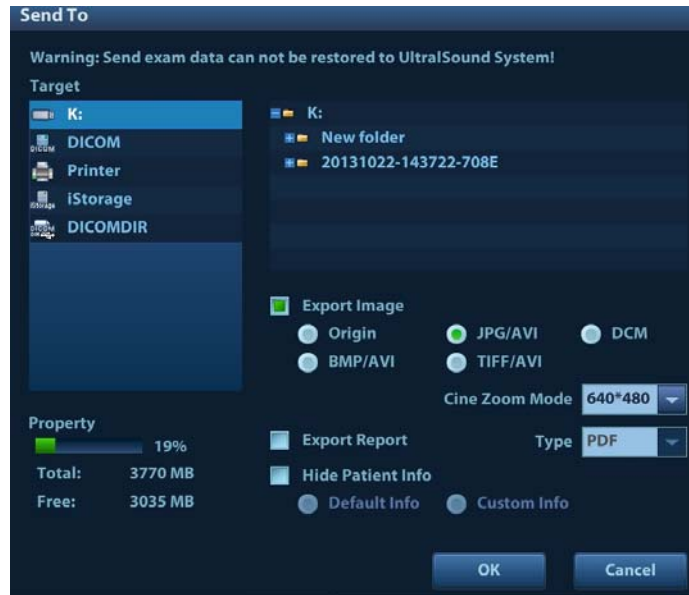

2. Select target:

- DICOM: send data or images to the storage server or send images to DICOM printer.
- DICOMDIR: back up data in DICOMDIR format; change the cine compression mode and JPEG compression mode.
- USB storage device or DVD-RW/DVD+RW drive: send exam to USB storage device or DVD-RW/DVD+RW drive.
 - Report format can be selected.
 - Format transfer is available when sending images to USB device or disk. See “10.2.12 Sending Image Files” for details.
- Print: send image to the connected printer to print.
Press <Ctrl> or <Shift> with the <Set> key on the control panel to select more than one exam at a time.

■ New Exam

After you select a patient data or exam in the iStation screen, click the [New Exam] to enter the Patient Info screen where you can select the exam mode and click [OK] to begin a new exam.

■ Select All/Deselect All

Click [Select All] to select all the patient data listed. The button changes to [Deselect All]. Cancel all the selections by clicking [Deselect All].

■ Activate an Exam

After selecting an exam which has been performed within 24 hours, click [Activate Exam] to activate the exam and load the basic patient information and measurement data to continue the exam.

If you want to select patient data in an external memory database to start a new exam or recover the exam, first allow the system to load the patient data to the system’s patient database.

■ Continue an Exam

Select an exam that has been paused within 24 hours, click [Continue Exam] to activate the exam and load the basic patient information and measurement data to continue the exam.

If you want to select patient data in an external memory database, first allow the system to load the patient data to the system’s patient database.

■ Recycle bin

The recycle bin is used to store deleted patient data, exam data and images (stored from deleting until the system is powered off).

To recover deleted patient data, click  in the bottom-right corner of the screen (when the button is gray, the operation is unavailable) to enter the Patient Recycle Bin screen.

- (1) Select items to be recovered in the list. Select operations:
 - Click [Restore Items] to restore the item to iStation.
 - Click [Delete] to delete the item permanently. The item can never be restored again.
 - Click [Restore All Items] to restore all the items to iStation.
 - Click [Empty Recycle Bin] to empty the recycle bin. All the items can never be restored again.
- (2) Click [Exit] to exit the Recycle Bin screen.

10.5 iStorage

iStorage is used to save image files and measurement reports to the remote PC server.

Open “[Setup] → [Network Preset]” to set the iStorage settings (see “12.8.1 iStorage Preset” chapter for details).

1. Enter the iStation screen. Select one (or more than one) patient data or image in the local data source.
2. Click [Send Exam].
3. Select [iStorage] in the Send To dialog box on the left and select the PC server on the right.
4. Select PC transfer format to send the report.
5. Click [OK] to start sending.

To use iStorage function, you need UltraAssist software in 2.0 version (with V1.0 network protocol); consult Mindray service engineer for details.

10.6 Print

10.6.1 Print Setting

For printer connection and driver installation, please refer to “3.7 Installing a Printer” chapter.

■ Print Service Setting

1. Open [Setup] → [Print Preset] and select an existing printer service from the list.
2. Select the printer type in the Property box.
3. Set printing properties.
4. Click [Save] to confirm the setting and exit the preset page.

■ User-defined shortcut key for printing

To use the <Print> key on the system's control panel, you may need to:

1. Press the <Setup> key to show the Setup menu. Click the [System Preset] item to open the [System Preset] screen, and click the [Key Config.] tab.
2. Click to select “P1” on the left. Click to select the desired print key on the right.
3. Click [Save] to exit the preset and make the settings effective. Press the <Print> key on the control panel to print.

■ Output settings:

Open [Setup] → [System Preset] → [General], then select the digital output mode: Full screen or stand area.

10.6.2 Image Printing

Image printing is mainly achieved by video printer. For DICOM image printing, see the DICOM chapter.

■ Modify a print service:

- (1) Select an existing printer service from the list.
- (2) Select the printer model, then set the properties in the Property box.
- (3) Click [Save] to complete.

■ Image print

1. Select the desired image in the iStation or Review screen.

2. Click the  icon on the top right side of the image, and select the printer in the dialog box which appears.
3. Click [OK] to start printing.

See the accompanying printer manuals for more details.

10.6.3 Report Printing

Both reports and images can be printed on a graph/text printer.

1. Press <Report> to enter the report dialog box.
2. Select [Print] to print the report.



See the accompanying printer manuals for more details.

10.7 Back Up Files using the DVD Drive

The system supports writing data to CD/DVD using the external DVD-RW/DVD+RW drive and reading data from CD/DVD on the PC.

The system supports the following media: DVD+RW, DVD+R, CD-RW, CD-R, DVD-R and DVD-RW.

■ To write data to a CD/DVD:

- (1) Put a CD/DVD in the tray.
- (2) Select the data to be backed up. Select [Send Exam] or [Back up Exam] in the menu which appears. Select the target drive in the Send To or Back Up Patient Record dialog box.
- (3) Click [OK] or [Back up] to begin writing when the  symbol displays.
- (4) After the writing process is complete, click  to bring up the Disc Option dialog box, and select [Eject] to eject the CD/DVD.

Tip:

- Writing data using “Send To” supports the PC format transfer function, while CD/DVD writing using “Back Up” supports only system-relevant formats.
- The  symbol indicates that the input CD/DVD is damaged or contains data in an incorrect format.

You can check the data writing procedure in the patient task manager. For details, see “10.8 Patient Task Management.”



CAUTION:

During the backup process, if a CD/DVD is forcibly taken out or you perform other operations, the backup process will fail or the system may malfunction.

10.8 Patient Task Management

Click  in the bottom-right corner of the screen to bring up the following dialog box:

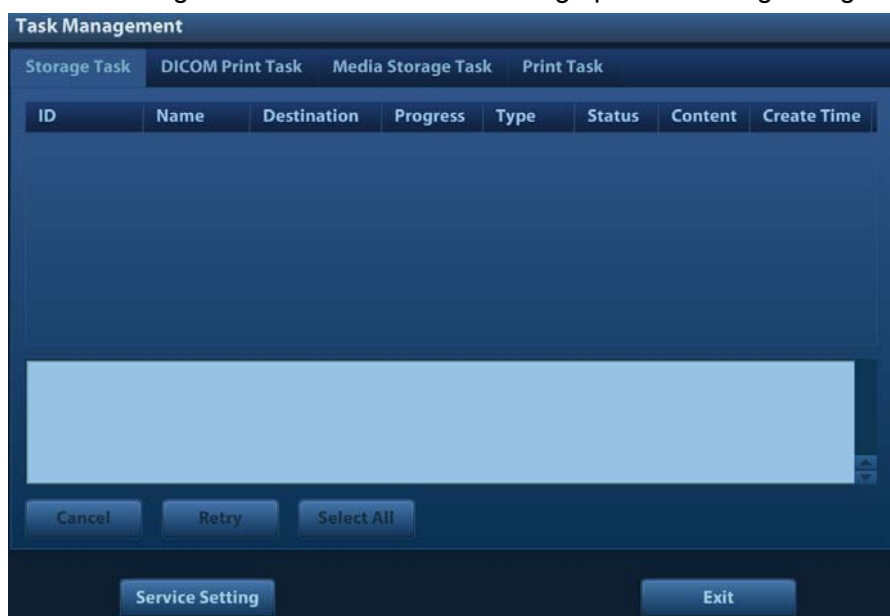

The system supports four types of task management:

- Storage Task: displays the DICOM storage task.
- DICOM Print Task: displays the DICOM print task.
- Media Storage Task:
 - DICOM media storage task (including disc and USB devices): in iStation screen, select the target exam and click [Send Exam], then click DICOMDIR in the menu which appears.
 - Back up task (system-relevant format): select the exam to be backed up in iStation and click [Back Up Exam].
 - Send to external devices (including disc and USB devices): select exam data or images in the iStation or Review screen. Click [Send Exam] or  for the image.
 - iStorage task: in iStation screen, select the target exam and click [Send Exam], then click iStorage in the menu which appears.
- Print Task: displays image or report printing tasks.

In the Task Management dialog box, the patient ID, name, destination, progress, type, contents and task created time are displayed.

You can perform the following operations:

- Click [Delete] to delete the task.
 - Click [Retry] to retry the failed task.
 - Click [Select All] to select all the tasks.
- Task Status

When there are tasks underway, the task management icon displays as . Click the icon to check the process.

When tasks have failed, the task management icon displays as . Click the icon to check the reason for the failure.

When the task management icon displays as , it means no task is underway or has failed.

- **DICOM Service Setting**

On the Storage Task and DICOM Print Task page, click [Service Setting] to enter the DICOM service setting screen. For details, see the DICOM chapter.

- **Troubleshooting**

If a serious error occurs, such as network disconnection or operation timeout, the system can try to reconnect the network. The interval time and maximum retries can be set as desired. For details, see the DICOM chapter.

10.9 Administration

10.9.1 Access Setting

The system supports two types of users: system administrator and operator.

- **Administrator**

The system administrator can view all patient data, such as patient information, images and reports, etc.

- **Operator**

The operator can only view exam information saved in the system and operated by him or herself, such as patient information, images and reports, etc. The operator cannot view exam data operated by others.

10.9.2 Setting Access Control

The system administrator can preset the access controls, that is, whether an operator has the right to access data in the system.

Access control only can be set by the system administrator.

Setting access control:

1. Open the “Admin” page using the path: [Setup] → [System Preset] → [Admin].
2. If **Enable User Account Control** is selected, you must be authorized before accessing the data. If unselected, you can access all the data without authorization.

10.9.3 System Login

If access control has been set by the system administrator, you can access data in the system only after logging onto the system.

You must log in again after system restart or dormancy.

- **Logging onto the system:**

1. The following dialog box appears:

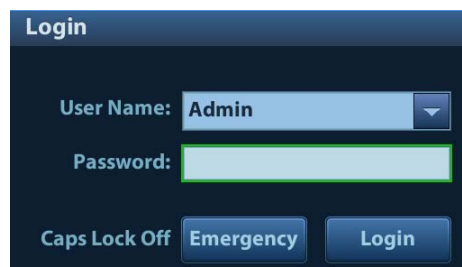

2. Select the user name in the User Name drop-down list.
3. Enter the password and click [Log in].

- To change users:

1. To log out the current user and change to another user, click  in the bottom-right corner of the screen to bring up the following dialog box:



2. Click [Change User] to bring up the Login dialog box.
3. Enter the user name and password in the field box.

- Lock the system

1. Click the  in the bottom-right corner of the screen to bring up the dialog box.
2. Select [Lock Machine] and the system is locked. You must log on before using the system.

10.9.4 Add/Delete Users

The system administrator can add and delete users, while the operator cannot.

Add a User

Turn on the access control function before you add the user.

1. Open the “Admin” page using the path: [Setup] → [System Preset] → [Admin].
2. Click [Add] to bring up the dialog box.
3. Select the user type and enter the user name and password.
4. Click [OK] to confirm the setting and exit the dialog box. The new user will appear in the User List.

Delete a User

Turn on the access control function before you delete the user.

1. Open the “Admin” page using the path: [Setup] → [System Preset] → [Admin].
2. Select the user to be deleted in the User List. Click [Delete] to delete the selected user.

10.9.5 Modify Passwords

The system administrator can modify all user passwords. The administrator password is empty by factory default. You can set this password.

An operator can only modify his/her own password. There are two ways to modify passwords: on the “Admin” page or in the “Session Manage” dialog box.

- “Admin” page (administrators can modify the password)

1. Open the “Admin” page using the path: [Setup] → [System Preset] → [Admin].
2. Select the user name to be modified in User List. Click [Change Password] to open the dialog box.
3. Enter the new password and confirm the password, then click [OK].

- Session Manage page (general operators and administrators can modify the password).

When the user has logged onto the system,  is visible in the bottom-right corner of the screen.

1. Click  in the bottom-right corner to bring up the Session Manage dialog box where you can see the current user’s information.

2. If you want to modify the current password, click [Change Password] to bring up the Change Password dialog box.
3. Enter both the previous and new passwords in the dialog box.
4. Click [OK] to exit.

10.10 V-Access

The ultrasound system can be used to log on to a remote server to check or modify patient data on the server.

1. Set the user-defined key via the path: [Setup] → [System Preset] → [Key Config]. Select a key in the Key Function field on the left side, and select “V Access” in the Other page of the Function field on the right side.
2. Press the user-defined key to use the function.
3. The system brings up a dialog box for entering the IP address of the remote server.

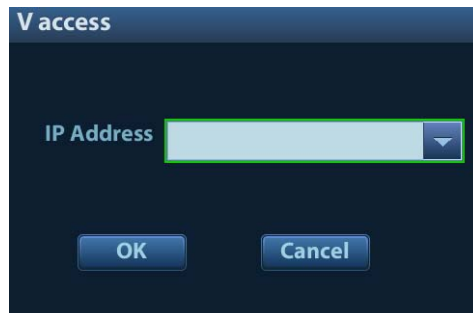

4. Enter the IP address and click [OK].
5. Log on with the server account and password.
6. Check the data transferred and carry out operations as necessary.

11 DICOM/HL7

NOTE: Before using DICOM, read the DICOM CONFORMANCE STATEMENT electronic file provided with the device.

The chapter is restricted to the preset, connection verification and DICOM services of the DICOM-configured ultrasound machine, and does not include SCP configurations such as PACS/RIS/HIS.

The DICOM package is optional. For details, see “2.5.3 Options”.

This system supports the following DICOM functions:

- Verify Connectivity
- DICOM Storage
- DICOM Print
- DICOM Worklist
- MPPS (Modality Performed Procedure Step)
- Storage Commitment
- Query/Retrieve
- Structured Report
- DICOM Medium Storage (DICOMDIR Review)
- DICOM Task Management

DICOM Preset and Applications workflows are briefly described as follows:

1. DICOM preset (network property, DICOM local preset, server and service preset).
2. Verify connectivity(click [Verify] in corresponding screen).
3. Services application.
4. DICOM task management.

■ Terms

Abbreviations	Description
DICOM	Digital Imaging and Communications in Medicine
AE	Application Entity
MPPS	Modality Performed Procedure Step
PDU	Protocol Data Unit
SCU	Service Class User (DICOM client)
SCP	Service Class Provider (DICOM server)
SOP	Service-Object Pair

11.1 DICOM Preset

11.1.1 IP Preset

See “Appendix A Wireless LAN” for details.

11.1.2 DICOM Local Preset

1. Enter the DICOM local preset screen using the path: [Setup] → [DICOM/hl7].
2. Enter AE Title, Port and PDU according to the actual situation, then click [Save] to exit the screen. Setting items are introduced in the following.

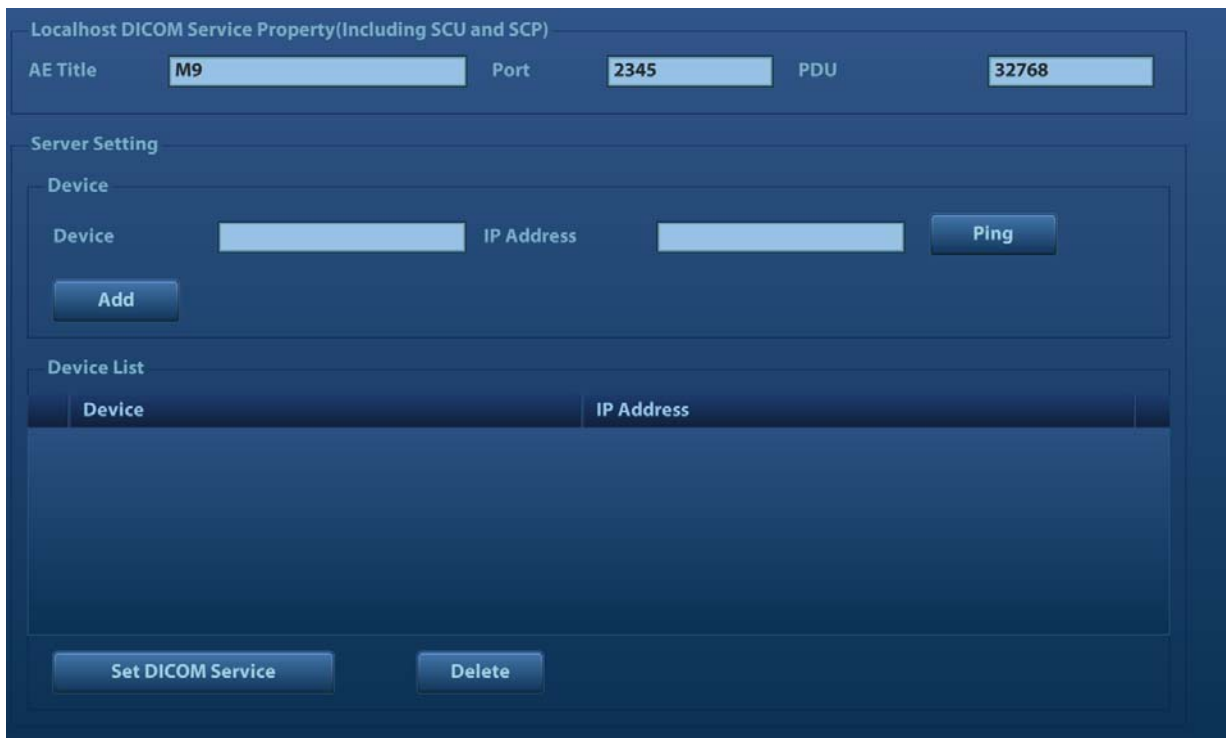

	Name	Description
DICOM Local	AE Title	Application Entity title.
	Port	DICOM communication port.
	PDU	Maximum PDU data package size, ranging from 16384 to 65536. If the value is less than 16384 or greater than 65536, the system automatically sets it to the value 32768.
Server Setting	Device	Name of the device supporting DICOM services.
	IP Address	IP address of the server.
	Ping	You can ping other machines after entering the correct IP address. You can also select a server in the Device list to ping it.
	Device List	Displays the added device.
	Set DICOM Service	Provides server settings of DICOM service. For details, see the following chapters.
	Add	Click to add servers to the Device List.

Name	Description
Delete	Click to delete selected servers from the device list.

■ Server setting procedure:

1. Enter the server device name and IP address. Click [Ping] to check the connection.
2. Click [Add] to add the server to the device list. Its name and address are displayed in the list.

Tip:

The AE Title should be the same as the SCU AE Title preset in the server (PACS/RIS/HIS). For example, if the AE Title of the server preset in the storage server is Storage, and the AE Title of the accepted SCU is preset as Machine, then in the figure above, the AE Title of Local should be Machine, and the AE Title of the storage server should be Storage.

11.1.3 Service Preset

The DICOM Service screen is used to set Storage, Print, Worklist, MPPS, Storage Commitment and Query/Retrieve attributes.

When the system is configured with the DICOM basic function module, and installed with DICOM Worklist, MPPS, DICOM structured reports and DICOM query/retrieve modules, the corresponding preset can be found in the DICOM Service screen.

To open the DICOM Service screen:

1. Press the <Setup> key to show the Setup menu.
2. Select [DICOM/HL7] and click [Set DICOM Service] to open the DICOM Service preset screen.

11.1.3.1 Storage Service Preset

1. On the DICOM Service screen, click the [Storage] page tab to enter the Storage page.
2. Select a device and enter the correct AE Title, port, etc.
3. Click [Add] to add the service to the Service List.

The screenshot displays the 'DICOM Service' configuration window, specifically the 'Storage' tab. The window title is 'DICOM Service' and the brand 'mindray' is visible in the top right corner. The 'Storage' tab is selected, with other tabs like 'Print', 'Worklist', 'MPPS', 'StorageCommitment', 'Query/Retrieve', and 'HL7Query' visible. The main area is titled 'Configure the New Service' and contains several input fields and dropdown menus: 'Device' (dropdown), 'Service Name' (text input), 'AE Title' (text input), 'Port' (text input, set to 104), 'Maximum Retries' (dropdown, set to 3), 'Interval Time(Sec)' (dropdown, set to 15), 'Timeout(Sec)' (dropdown, set to 15), 'Cine Zoom Mode' (dropdown, set to Original), 'Compression Mode' (dropdown, set to Uncompressed), 'Compression Ratio' (dropdown, set to Lossless), 'Color Mode' (dropdown, set to Color), 'Allow Multiframe' (checkbox, checked), 'Max Framerate' (dropdown, set to 35), '3D/4D' (dropdown, set to Normal), and 'SR Storage Option' (dropdown, set to Not Store SR). There is also an 'Encapsulated PDF' checkbox. Below these fields are 'Add', 'Cancel', and 'Update' buttons. A 'Service List' table is shown below, with columns: Device, Service Name, AE Title, Port, and Default. The table is currently empty. At the bottom, there are 'Delete', 'Default', and 'Verify' buttons, a 'Verification is required!' message, and an 'Exit' button. The system tray at the bottom right shows '[Save]', a taskbar, and the time '03:25:20'.

DICOM storage preset items are described as follows:

Name		Description
Configure New Service	Device	After setting the servers in the DICOM Preset screen, the names will appear in the drop-down list. Select the name of the storage server.
	Service Name	The default is xxx-Storage, user-changeable.
	AE Title	Application Entity title. It should be consistent with that of the storage server.
	Port	DICOM communication port, 104 is the default. The port should be consistent with that of the storage server port.
	Maximum Retries	Set the maximum retries.
	Interval Time(s)	Interval time for the system to retry a connection.
	Timeout	Refers to the amount of time after which the system will stop trying to establish a connection to the service.
	Cine Zoom Mode	Select the cine zoom mode during image file storage.
	Compression Mode	Select the compression mode: uncompressed, RLE, JPEG and JPEG2000.
	Compression Ratio	Select the JPEG compression ratio: lossless, low, medium and high.
	Color Mode	Select the color mode.
	Allow Multiframe	If SCP supports this function, select it.
	Max. Frame Rate	Set the frame range for transferring cine files to DCM multi-frame files.
	3D/4D	/
	SR Storage Option	To enable or prevent structured report sending.
	Encapsulated PDF	Select whether to encapsulate PDF format reports in DICOM standard.
Add	Add the DICOM service to the service list.	
Cancel	Click to cancel parameter setting.	
Update	Select an item in the service list, change the parameters in the above area, and click [Update] to update the item in the service list.	
Service List	Delete	Click to delete the selected service from the service list.
	Default	Select an item in the service list. Click [Default] and you will see "Y" in the Default column.
	Verify	Click to verify that the two DICOM application entities are properly connected.

Tip: RLE, JPEG and JPEG2000 are not supported by all SCPs. Refer to the SCP's DICOM CONFORMANCE STATEMENT electronic file to check whether SCP supports it or not. Do not select these compression modes if the storage server does not support them.

- Images of PW/M/TVM/TVD mode (B image is not frozen) and images other than PW/M/TVM/TVD mode: if "Max Frame rate" is not "Full" and the actual frame rate is larger than the set value, the system will save the image files in a frame rate of the set value, and transfer in a frame rate of B mode.

- Images of PW/M/TVM/TV mode (B image is frozen), the system will save/transfer the images files in frame rate of 6.

11.1.3.2 Print Service Preset

1. On the DICOM Service screen, click the [Print] page tab to enter the Print page.
2. Select a device and enter the correct AE Title, port, etc.
3. Click [Add] to add the service to the Service List.

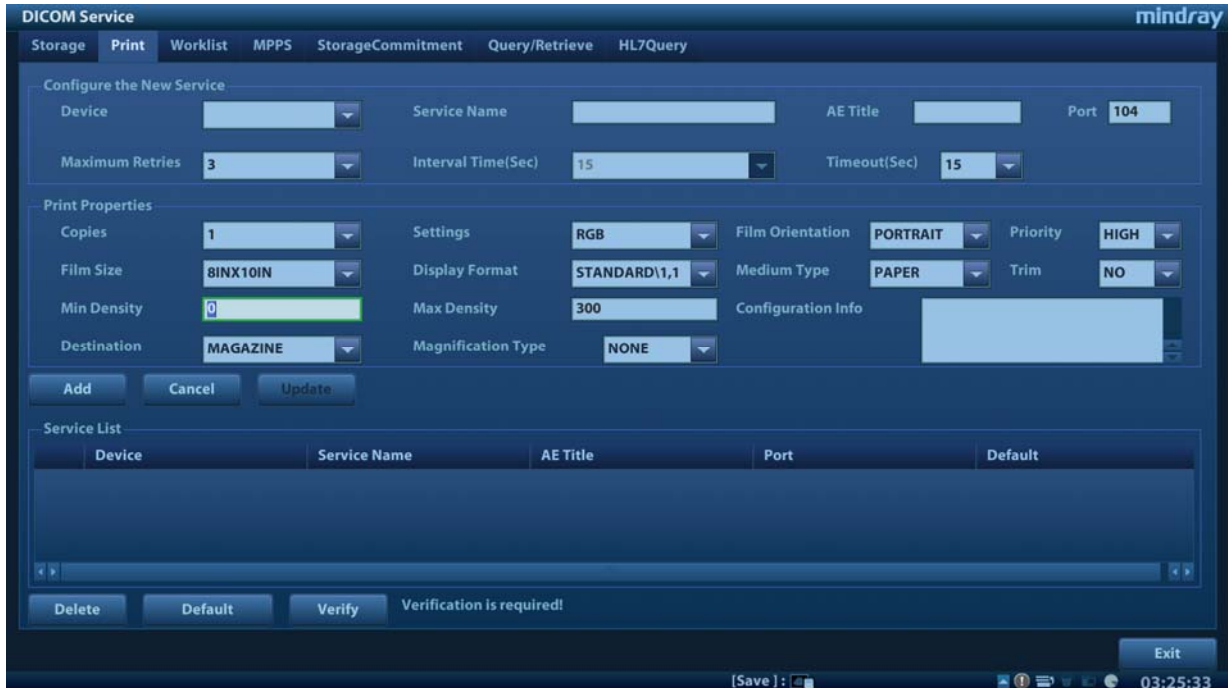

DICOM print preset items are described as follows:

	Name	Description
Configure New Service	Device	After setting the servers in the DICOM Preset screen, the names will appear in the drop-down list. Select the name of the print server.
	Service Name	The default is xxx-Print, user-changeable.
	AE Title	Application Entity title. It should be consistent with that of the print server.
	Port	DICOM communication port, 104 is the default. The port should be consistent with that of the print server port.
	Maximum Retries	Set the maximum retries.
	Interval Time(s)	Interval time for the system to retry a connection.
	Timeout	Refers to timeout during association establishment.
Print Properties	Copies	See copies of printed files. You can select from 1 to 5, or directly enter the number.
	Settings	The system supports RGB (color printing) and MONOCHROME2 (black and white printing). Please select the type the printer supports.
	Film Orientation	Select from between LANDSCAPE and PORTRAIT.

Name	Description	
Priority	Specify printing task priority from HIGH, MED and LOW.	
Film Size	Select film size from the selections listed in the drop-down list.	
Display Format	Specify the quantity of printed files, e.g., STANDARD\3, 2 indicates 6 images are printed for each page.	
Medium Type	Specify print medium: Paper, Clear Film, Blue Film. Select Blue Film or Clear Film for black and white printing; select Paper for color printing.	
Trim	Specify whether you want a trim box to be printed around each image on the film: Yes or No.	
Configuration Info	Enter configuration information in the field.	
Min. Density	Enter the minimum density of the film.	
Max. Density	Enter the maximum density of the film.	
Destination	Specify where the file is exposed: MAGAZINE (stored in the magazine) or PROCESSOR (exposed in the processor).	
Magnification Type	<p>Select how the printer magnifies an image to fit the film.</p> <p>Replicate: interpolated pixels belong to duplicates of adjacent pixels)</p> <p>Bilinear: interpolated pixels are generated from bilinear interpolations between adjacent pixels</p> <p>Cubic: interpolated pixels are generated from cubic interpolations between adjacent pixels</p> <p>None: without interpolation.</p>	
Add	Add the DICOM service to the service list	
Cancel	Click to cancel parameter preset.	
Update	Select an item in the service list, change the parameters in the above area, and click [Update] to update the item in the service list.	
Service List	Delete	Click to delete the selected service from the service list.
	Default	Select an item in the service list. Click [Default] and you will see "Y" in the Default column.
	Verify	Click to verify that the two DICOM application entities are properly connected.

11.1.3.3 DICOM Worklist Preset

1. On the DICOM Service screen, click the [Worklist] page tab to enter the Worklist page.
2. Select a device and enter the correct AE Title, port, etc.
3. Click [Add] to add the service to the Service List.

The DICOM Worklist service parameters are similar to those described in DICOM Storage Preset. See “11.1.3.1 Storage Service Preset” for details.

11.1.3.4 MPPS Preset

1. On the DICOM Service screen, click the [MPPS] page tab to enter the MPPS page.
2. Select a device and enter the correct AE Title, port, etc.
3. Click [Add] to add the service to the Service List.

The DICOM MPPS service parameters are similar to those described in DICOM Storage Preset. See “11.1.3.1 Storage Service Preset” for details.

11.1.3.5 Storage Commitment Preset

1. On the DICOM Service screen, click the [Storage Commitment] page tab to enter the Storage Commitment page.
2. Select a device and enter the correct AE Title, port, etc.
3. Click [Add] to add the service to the Service List.

A special setting item for the DICOM Storage Commitment service is the Associated Storage Service, as described in the following. Other parameters are similar to those described in DICOM Storage Preset. See “11.1.3.1 Storage Service Preset” for details.

Name	Description
Associated Storage Service	The associated storage server should be preset before storage commitment. Storage commitment can only be created after the exam is sent out.

11.1.3.6 Query/Retrieve Preset

1. On the DICOM Service screen, click the [Query/Retrieve] page tab to enter the Query/Retrieve page.
2. Select a device and enter the correct AE Title, port, etc.
3. Click [Add] to add the service to the Service List.
4. Click [Exit] to confirm the preset and exit the page.

The DICOM Query/Retrieve service parameters are similar to those described in DICOM Storage Preset. See “11.1.3.1 Storage Service Preset” for details.

11.1.3.7 HL7Query Preset

HL7 protocol, enacted by Health Level Seven organization in 1987, is a 7th layer (application layer) based on the OSI model (Open System Interconnection) released by ISO (International Standard Organization). HL7 is used to rule and manage communications between HIS/RIS system and devices, as well as reduce the intercommunication cost.

The following HL7 protocol versions are supported in the ultrasound system: V2.3, V2.4, V2.5 and V2.6.

1. On the DICOM Service screen, click the [HL7Query] page tab to enter the HL7Query preset page.
2. Select a device and enter the correct AE Title, port, etc.
3. Click [Add] to add the service to the Service List.

Two special setting items for the HL7Query service are the Listen Port and Listen Mode, as described in the following. “Verify” function is not available under HL7Query preset. Other parameters are similar to those described in DICOM Storage Preset. See “11.1.3.1 Storage Service Preset” for details.

Name	Description
Listen Mode	This function enables the ultrasound system to use the listen port for data receiving.
Listen Port	Port for ultrasound system to receive data after the listen mode function is activated. Here, the port should be consistent with that of the Worklist server port. For details of listen port setting, refer to settings in the server.

11.1.3.8 Other Settings

You can configure different type of DICOM services in different scenarios. See “12.1.7.2 Scene Preset Management” chapter for details.

11.2 Verify Connectivity

To verify connectivity (not essential), click the [Verify] button on the Storage, Print, Worklist, MPPS, Storage Commitment and Query/Retrieve pages respectively.

If the verification is successful, the system displays “xxx Verify Succeed.” Otherwise, it displays “xxx Verify Failed.”

If verification failed, possible causes may be:

- The ultrasound machine cannot communicate normally with the server. Check that the cable is properly connected, or, Check that the IP of the server is configured in the same segment as that of the ultrasound machine, or, Check that the network adapter, router, exchanger and HUB are working normally.
- The server does not support the verification. If the connection is normal, it can be concluded that the server does not support the verification.
- The server supports the verification, but this function is not activated. Please check that the verification function is activated.

Tip:

Not all SCPs can support verification. See the SCP properties to confirm whether the SCP can support this service. If not, the verification will not be successful.

11.3 DICOM Services

If all the DICOM presets on the DICOM Service Preset screen are completed, you are ready for the Storage, Print, Worklist, MPPS, Storage Commitment and Query/Retrieve applications.

11.3.1 DICOM Storage

DICOM Storage is used to send images to the DICOM storage server for storage.

■ Send images on iStation/Review/main screens

(1) Select images

- Press <iStation> on the control panel to open the iStation screen. Click to select a patient or an exam record in the list. Thumbnails are displayed in the thumbnail area in the lower part of the screen, then click to select a thumbnail or several thumbnails. Or
- Press <Review> on the control panel to enter the Review screen. Click to select a thumbnail or several thumbnails. Or
- On the main screen, select a thumbnail or several thumbnails.

(2) Click in the top-right part of the image to bring up the following dialog box.

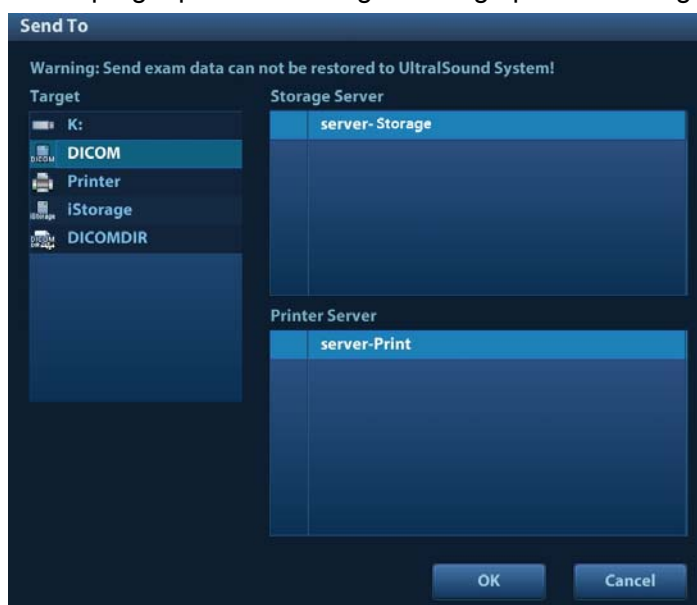

(3) Click to select “DICOM” in the Target box on the left side, then select the DICOM storage server in the Storage Server box on the right side.

(4) Click [OK] to start sending.

■ To send images using a shortcut key

You can save single-frame images or multi-frame images to a DICOM server while saving to hard drive using a shortcut key. The procedure is as follows:

(1) Define the key. For details, see “10.2.8 Auxiliary Output Function”.

(2) Set a default storage server:

- a) Enter the DICOM Service Preset screen via “[Setup]→ [DICOM Preset] → [Set DICOM Service].”
- b) Select a storage server in the Service List and click [Default]. You will see “Y” marked in the Default column.
- c) Click [Exit] to exit the page and return to the Setup menu, then click [Save] on the Setup menu to make the preset take effect.

(3) Press the key to send to DICOM storage.

- To send images to storage after an exam ends
 - (1) Open “[Setup]→ [System Preset] → [General]” and then check  in the Patient Info area.
 - (2) Set a default storage server.
 - a) Enter the DICOM Service Preset screen via “[Setup]→ [DICOM Preset] → [Set DICOM Service].”
 - b) Select a storage server in the Service List and click [Default]. You will see “Y” in the Default column.
 - c) Click [Exit] to exit the page and return to the Setup menu, then click [Save] on the Setup menu to make the preset take effect.
 - (3) After finishing the presets, perform image scanning. Each time <End Exam> is pressed on the control panel, the system will send the image to the default DICOM storage server for storage.

11.3.2 DICOM Print

DICOM Print is used to send images to the DICOM print server for printing.

- Print images on iStation/Review/main screens
 1. Select images. Operations are the same as for DICOM storage.
 2. In the Send To dialog box, select a DICOM print server. (For the dialog box, see DICOM Storage).

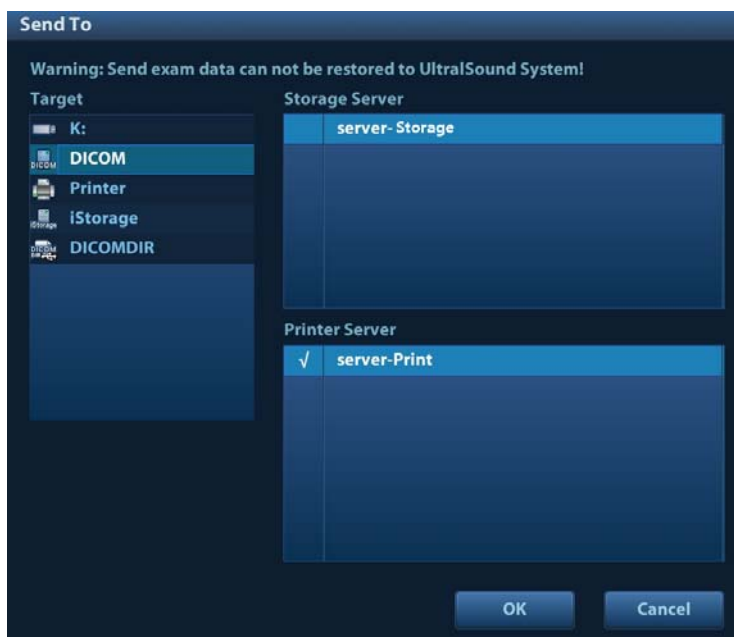

3. Click [OK] to begin printing.

- To send images using a shortcut key

You can send single-frame images to a DICOM print server while saving to hard drive using a shortcut key.

 1. Define the short key. For details, see “10.2.8 Auxiliary Output Function”.
 2. Set a default printer server
 - a) Enter the DICOM Service Preset screen via “[Setup]→ [DICOM Preset] → [DICOM Service].”
 - b) Click [Print] to open the Print page.

- c) Select a Print server in the Service List and click [Default]. You will see “Y” marked in the Default column.
 - d) Click [Exit] to exit the page and return to the Setup menu, then click [Save] on the Setup menu to make the preset take effect.
3. Press Key1 (defined as the shortcut key for Save Image to Hard Disk and Send to DICOM Printer). The system captures the current screen and sends it to the print server.
- To print images for storage after an exam ends
 - (1) Open “[Setup]→ [System Preset] → [General]” and then check  in the Patient Info area.
 - (2) Set a default print server.
 - a) Enter the DICOM Service Preset screen via “[Setup]→ [DICOM Preset] → [DICOM Service].”
 - b) Click [Print] to open the Print page.
 - c) Select a Print server in the Service List and click [Default]. You will see “Y” marked in the Default column.
 - d) Click [Exit] to exit the page and return to the Setup menu, then click [Save] on the Setup menu to make the preset take effect.
 - (3) After finishing the presets, perform image scanning. Each time <End Exam> is pressed on the control panel, the system will send the image to the default DICOM print server for printing.

11.3.3 DICOM Worklist

For details, see “4.1.2.2 Worklist”.

11.3.4 MPPS

MPPS is used to send exam state information to the configured server. This facilitates the other systems in obtaining the exam progress in time.

The status information is described as follows:

- When you begin an exam or send images during an exam, the system sends “Active” status information to the MPPS server.
- When the exam is complete, the system sends “End” status information to the MPPS server.
- When a paused exam is continued, the system sends “Active” status information to the MPPS server.
- When an exam is canceled, the system sends “Canceled” status information to MPPS server.

11.3.5 Storage Commitment

Storage commitment is used to confirm whether the images or structured reports are successfully stored on the DICOM storage server.

Before using storage commitment, set the associated storage service.

- Storage commitment after sending images on the iStation screen.
 1. Open the iStation screen.
 2. Select an exam (a suspended exam or an inactive exam) (images are stored in the exam record). Click the [Send Exam] button in the menu which appears to open the Send To dialog box.
 3. Click to select “DICOM” in the Target box on the left side, then select the DICOM storage server in the Storage Server box on the right side.

4. Click [OK] to start sending. The system will send all the images stored in the exam record to the storage server. Meanwhile, it will send storage commitment to the storage commitment server.

■ To send storage commitment after an exam ends

1. Open [Setup] → [System Preset] → [General], then check

 Sending/printing after End Exam in the Patient Info area.

2. Set the default storage server and storage commitment server.

a) Enter the DICOM Service Preset screen via “[Setup] → [DICOM Preset] → [Set DICOM Service].”

b) Set a default server in the Storage page and set the associated storage service in Storage Commitment page.

c) Click [Exit] to exit the page and return to the Setup menu, then click [Save] on the Setup menu to make the preset take effect.

3. After finishing the presets, perform image scanning. Each time <End Exam> is pressed on the control panel, the system will send the image to the default DICOM storage server for storage and send storage commitment to the storage commitment server.

If images are successfully sent to the storage server, the storage commitment server will return information about the successful image storage. In the iStation screen, you will see a

tick “√” marked in the list below .

Tip:

Storage commitment is confined to the whole exam. Not each image sending can be indicated.

NOTE: Multi-frame storage is not allowed if “Allow Multiframe” is not selected ([Setup] → [DICOM Preset] → [Set DICOM Service] → “Storage”). For example, even if there is a multi-frame file in the exam to be sent, only single-frame image storage will be performed. After the storage is complete, there is no “√” marked in the list below  in the iStation screen.

11.3.6 Query/Retrieve

The query/retrieve function is used to query and retrieve patient exam records in a designated server. After setting the DICOM query/retrieve server, you can perform the query/retrieve function in the iStation screen.

1. Open the iStation screen: press <iStation> on the control panel, or, press <Info> on the control panel and then click [iStation] on the Patient Info screen.

2. Click [Query/Retrieve] to open the screen.

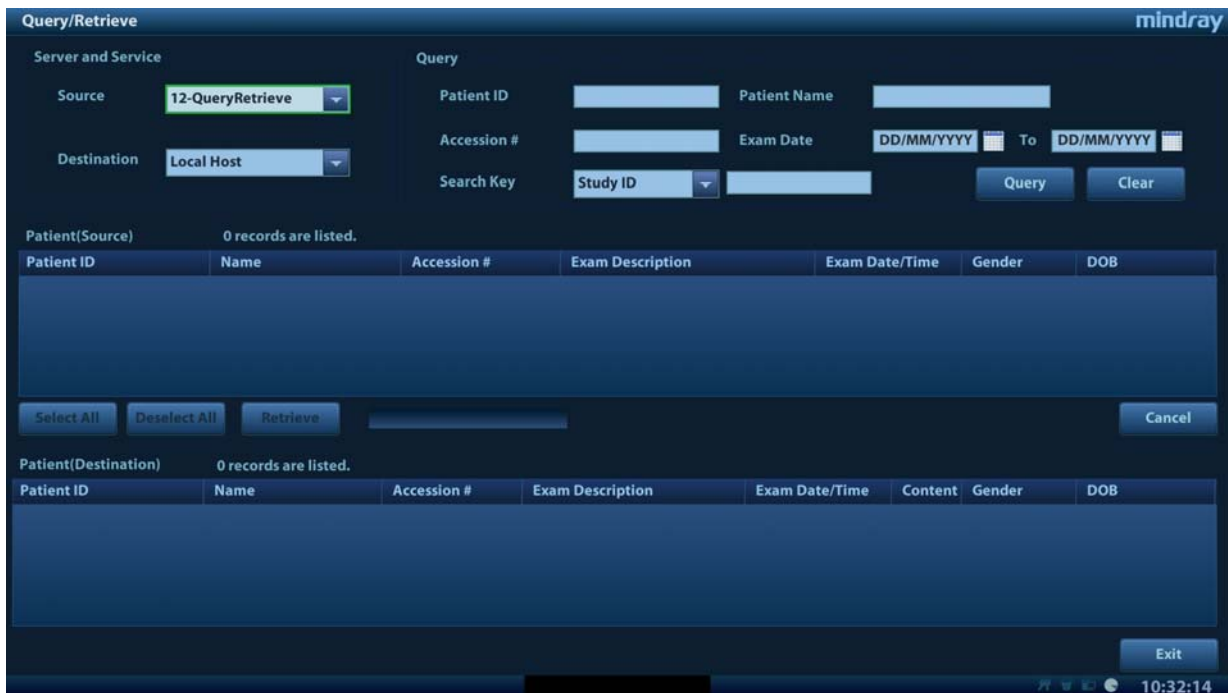

3. Select the server in the “Server and Service” area (both the source and the destination).
4. Enter the query information, such as Patient ID, Patient Name, Accession #, Exam Date or key words.
Click [Clear] to empty the entered query information.
5. Click [Query]. The system performs the query and lists the results in the patient (source) list. You can perform further queries based on the results by entering new query information.
6. Select one or more patient records according to the actual situation.
Click [Select All] to select all the patient records in the list.
Click [Deselect All] to deselect all the patient records in the list.
7. Click [Retrieve] to retrieve the patient records in the DICOM query/retrieve server to the local machine.
8. Click [Exit]. The retrieved patient records are listed in the iStation screen.

11.4 DICOM Media Storage

Patient data in the ultrasound system can be saved on external media in DCM format, while DCM files can be accessed in the ultrasound system.

Media Storage

1. Select patient records in the iStation screen.
2. Click [Send Exam] in the menu which appears to open the dialog box.
3. Select the destination to “DICOMDIR” and DICOM Format as well as compression mode.
4. Set whether to remove the patient data from the local hard disk after backup (remove exams or just remove the images).
5. Click [OK] to begin the storage.

If the backup is successful, a tick will appear in the Backup list in the iStation screen. If not, there will be no tick.

There must be no DICOMDIR/DCMIMG/IHE_PDI files on the external storage media of the same name as the one being backed up. Otherwise, the backup cannot proceed. Ensure there is enough storage space, or the backup may fail due to shortage of space.

Data Restore

After the DICOM format data are saved to external media, restore the data to the ultrasound system.

1. Connect the external media containing DCM files to the system.
2. In iStation, review the data stored on the external media.
3. Select the data to be restored in iStation.
4. Click  on the iStation screen.

NOTE: Only system-accessible media can be selected.

11.5 Structured Report

DICOM OB/GYN Structured reports, Cardiac Structured reports, Vascular Structured reports and Breast Structured reports are supported by this system. They can be sent together with the exam only.

- Send images and structured reports for storage in the iStation screen
 - (1) Select “Attach SR When Storing Images” OR “Only Store SR” on the DICOM Storage preset page. For details, see “11.1.3.1 Storage Service Preset.”
 - (2) Create new patient information or load scheduled patient information.
 - (3) Perform measurements.
 - (4) Save the images.
 - (5) End the exam.
 - (6) Open the iStation screen, select the patient exam, and click the corresponding [Send Exam] button in the menu which appears in order to open the Send To dialog box.
 - (7) Click to select “DICOM” in the Target box on the left side, then select the DICOM storage server in the Storage Server box on the right side.
 - (8) Click [OK]. Check for the result in the DICOM Task Management dialog box. After successful storage of both the image and structured report, you will see the storage commitment mark “√” in the list below  in the iStation screen.

The structured report can be sent automatically. For details, see “11.3.1 DICOM Storage.”

- Back up structured report

When recording or storing exams that have structured reports to external media (DICOMDIR), the structured reports can be backed up together.

NOTE: Only the PACS system from the Medstreaming company (<http://www.medstreaming.com/default.aspx>) supports sending self-defined measurements by DICOM SR.

11.6 DICOM Task Management

DICOM Task Management is used for viewing task progress or managing tasks after sending images for storage, printing or media storage. For details, see “10.8 Patient Task Management.”

12 Setup

The Setup function is designed to set the configuration parameters of operating the system and maintaining user workflow setup data. The setup data of the user and system are stored to the hard drive, and should be backed up to CD/DVD or USB memory device.



CAUTION:

When the preset data is changed, be sure to save the preset data according to the methods described in this chapter. Mindray is not responsible for the loss of preset data.

- To enter Setup:
Press the <Setup> key on the keyboard to enter the setup menu.
- To exit Setup:
Select [Save] in the Setup menu. The parameter settings are saved.
Select [Cancel] in the Setup menu or press <ESC> to close the Setup menu.
When you change the system language and click [OK] in the Setup menu, the system automatically shuts down to make the modification effective.
- Basic operations
The commonly-used setting types are:
 - Text box: position the cursor over the corresponding field box. Enter the desired value using the keyboard or soft keyboard on the soft menu.
 - Radio button: click the button to select an item.
 - Check box: click the checkbox to select one or more options.
 - Drop-down list: click the arrow beside the list to select an item.

12.1 System Preset

The system automatically enters the [System Preset] screen after you enter Setup.



Page	Description
Region	To set the hospital name, language, time zone, time format and system date/time.
General	To set patient information, exam setup, patient management, storage, system dormancy, auxiliary output setting and so on.
Image	To set general parameters in imaging modes.
Application	To set the measurement ruler, measurement setting, follicle method, left ventricular setting, comment setting and so on.
OB	To set the relevant information regarding the fetal gestational age, fetal growth formula and fetal weight.
Key Config.	To assign functions to the foot switch and user-defined keys.
Admin	To set the user account control relevant information.
Scan Code	To set the code parameters for barcode reader.

12.1.1 Region

Open the Region page via [Setup] → [System Preset] → [Region].

Item	Description
Hospital Information	To set the hospital-relevant information such as name, address, telephone, and so on.
Language	To select a language (input) for the system. Available languages are Chinese, English, French, German, Italian, Portuguese, Russian, Spanish, Polish, Czech, Turkish, Norwegian, Serbian, Finnish (can be entered only), Danish (can be entered only), Icelandic (can be entered only), Swedish (can be entered only) and Hungarian (can be entered only).
Load Logo	Import image for logo loading. <div style="border: 1px solid black; padding: 5px; margin-top: 5px;"> <p>NOTE: For a better display effect, please try to use an image with 400*400 pixels.</p> </div>
Time Zone	To select the time zone.
Time Format	To select the time format.
Date Format	To set the date format.
System Date	To set the date for the system.
System Time	Move the cursor over the corresponding field and enter the time manually using the keyboard, or, move the cursor over the time segment and press <Set>, then increase or decrease the required value by clicking the icons on the right side.
Time Sync	To assign a time server and make the time of the ultrasound machine consistent with the server.

12.1.2 General

Open the page via [Setup] → [System Preset] → [General].

Type	Item	Description
Patient Info	Info displays in an image banner	To select whether to display the available patient information items on the screen.
	H&W Unit	To set the unit for calculating patient height and weight.
	Surface Formula	To set the surface formula.
Exam Setup	Status after exam ends	To set the system status when an exam ends.
	Sending/printing after End Exam	Select whether to automatically archive the exam data to the DICOM server for storage/print.
Storage	Image size	To set the size for a stored image or text/digital printer printing.
	AVI File Encode Format	Set the code format for AVI transfer. When using the Send To function, the system transfer the image by settings (see “10.2.12 Sending Image Files” for details.)
	Digital Output	To set the size for digital signal (VGA and HDMI) output.
	Analog Output Mode	To select the format for analog signal (S-Video) output: NTSC or PAL.
	Clip Length	To set the cine length and heart cycle.
	Prospective Cine Length	To set the cine length for prospective live capture.
	Retrospective Cine Length	To set the cine length for retrospective live capture.
Display	Brightness auto adjustment	To set whether to use auto brightness auto control.

Type	Item	Description
	Contrast	Click [-] or [+] to decrease/increase the contrast value.
Screen Saver	Screen Saver	To select a system dormancy type. After the screen saver function is enabled, click [Browse] to select the figure used for the screen saver and click [Preview] to see the effect. To set the delay before the system enters dormancy/standby status in the drop-down list beside "Wait."

12.1.3 Image Preset

Open the page via [Setup] → [System Preset] → [Image].

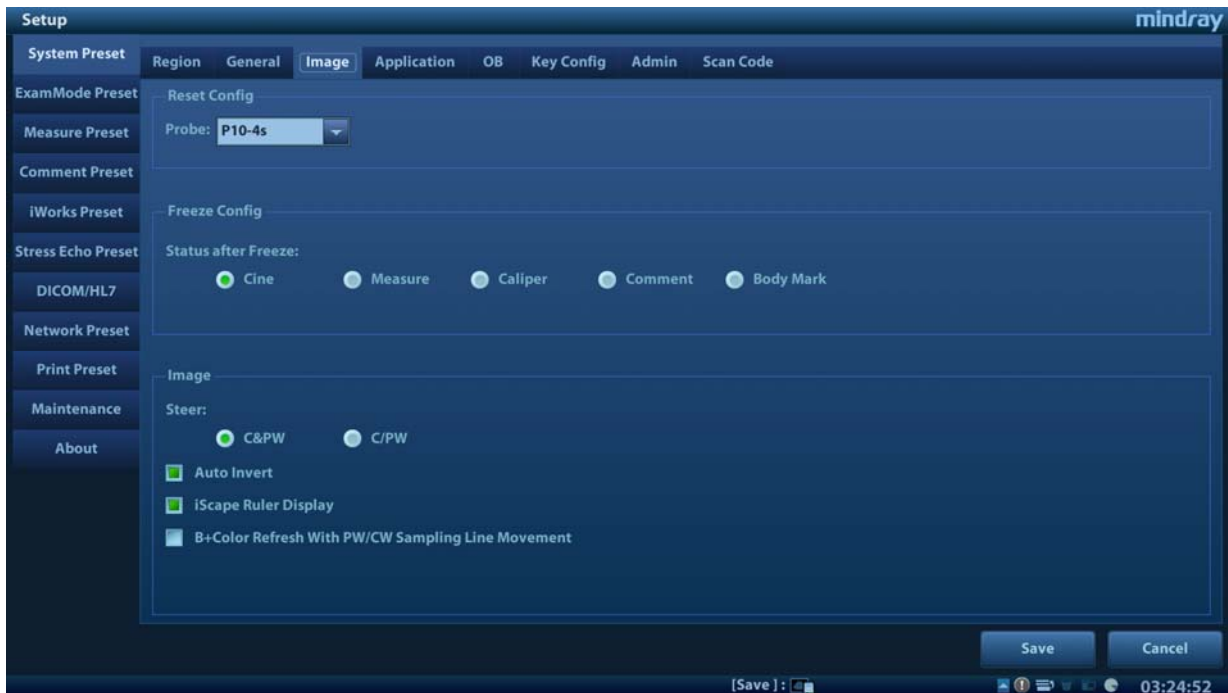

Type	Item	Description
Reset Config.	Probe	To set the default probe model for the system.
Freeze Config.	Status after Freeze	To set the system status after the image is frozen.
Image	Steer	To set the steer mode in B + Color + PW imaging mode. C&PW: select to adjust the sample volume in color mode and sample line in PW mode together. C/PW: select to adjust the sample volume in color mode and sample line in PW mode separately.
	Auto Invert	The spectrum can automatically invert when the color flow is steered to a certain angle, thus accommodating the operator's wish to distinguish the flow direction.
	iScape Ruler Display	To set whether to display the iScape ruler in iScape imaging mode.
	B+Color Refresh with PW/CW Sampling Line Movement	To set whether to turn on the function that when moving PW/CW sampling line, B image is activated under B+Color+PW/CW mode.

12.1.4 Application

Open the page via [Setup] → [System Preset] → [Application]. On this page, you can set the measurement ruler and relevant information. For details, see the Operator's Manual [Advanced Volume]

12.1.5 OB Preset

Open the page via “[Setup] → [System Preset] → [OB].” On this page, you can set the gestational age formula, fetal growth formula, fetal weight formula and relevant information. For details, see the Operator's Manual [Advanced Volume].

12.1.6 Key Configuration

Open the page via “[Setup] → [System Preset] → [Key Config.]”

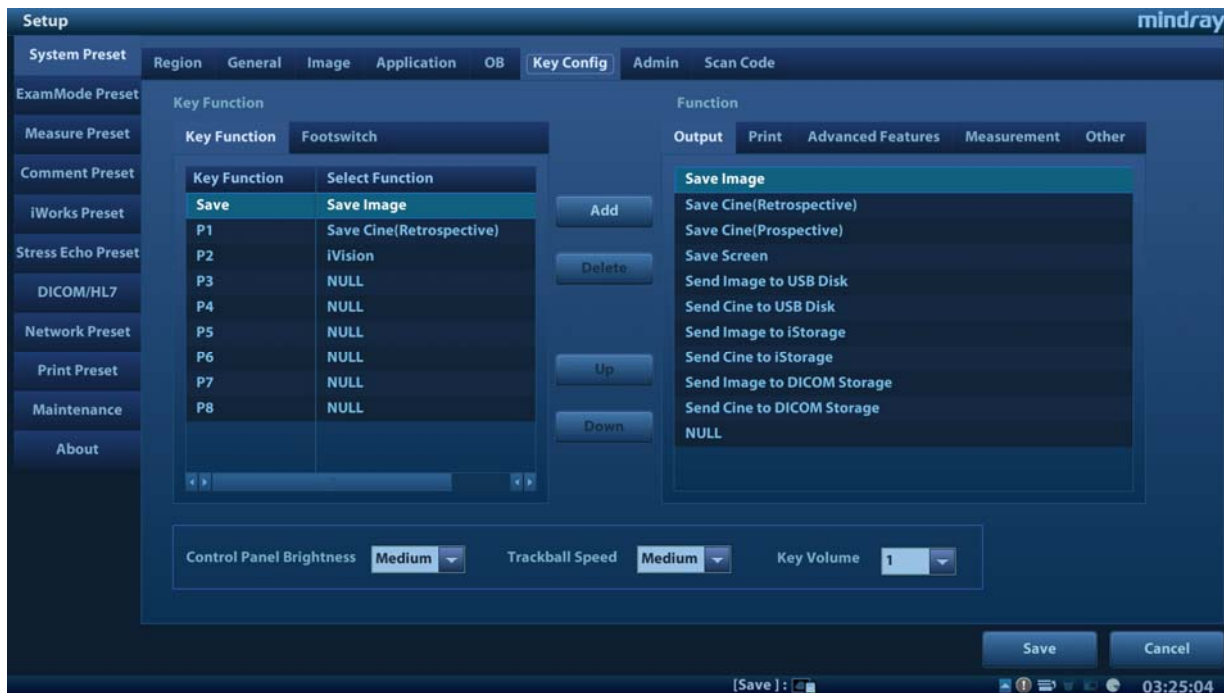

■ Key function setting

You can set the functions for <Save>, P1-P8.

To assign a function to a key:

- Click to select the desired key in the Key Function column on the left side of the page.
- Click to select a function in the Function area. You can see the available functions selected on the right side.
- Click [Save] to complete the function setting.

■ Foot switch function setting

You can assign a function to the left/middle/right key of the foot switch. The method is similar to setting key functions. See the steps above.

■ Other Settings

Item	Description
Key Volume	To set the key volume at 3 levels, 0 means no sound.
Trackball Speed	To set the speed of the trackball when moving the trackball.
Control Panel Brightness	To set overall brightness of control panel elements (including trackball and key backlights)

12.1.7 Admin

Open the page via “[Setup] → [System Preset] → [Admin].”

12.1.7.1 Access Control

For access control details, see “10.9 Administration.”

12.1.7.2 Scene Preset Management

The system can manage preset data under different scene applications. When the feature is turned on, you can use different preset data for print, DICOM and iStorage services. Configurable DICOM preset function includes DICOM Storage, DICOM Print, Worklist, MPPS and Query/Retrieve.

■ To enable the function:

1. Enable the function through the path: [Setup]->[System Preset]->[Admin].
2. Click [Save] to confirm.

■ Switch different scenarios:

1. In non-preset screen, press <Cursor> to show the cursor and move the cursor to the bottom-right corner of the screen. Click  icon to see the scene management list.



2. Position the cursor on the target scene and press <Set> to switch.

■ Configure scenes:

1. Click  icon to see the scene management list.
2. Click [Configure] to see the following dialogue box.



- Add scenes: click [Add] and enter the scene name in the Add Scene dialogue box and then click [OK].
- Configure scenes:
 - a) Click to select the target scene name in the Scene Name list on the left side.
 - b) Click [Print Preset] on the right to open the screen.
 - c) Set all necessary parameters and click [Save] to exit.
 - d) Repeat step b-c to finish DICOM and iStorage module configuration if necessary.
 - e) Click [Exit] to exit configuration.

12.1.8 Scan Code Preset

See “D.3 Setting in Ultrasound System” chapter for details.

12.2 Exam Preset

Open “[Setup] → [Exam Preset]” to enter the screen.



You can assign available exam modes for probes.

1. To select a probe, move the cursor over the Probe column and select the probe model using the drop-down list.
2. Select/delete exam modes:

On the left side, you can view all the available exam modes in the exam library for the probe.

On the right side of the screen, you can view the current exam modes assigned to the probe.

- Select the exam from the Exam Library on the left and click [>] to add it to the Exam Mode Selected.
- Click [<<] to delete all exam modes in the Exam Selected area.
- To delete an exam supported by the current probe, first select the exam and then click [<] to delete it.
- Click [Delete] to delete a user-defined exam in the Exam Mode Library area.
- Click [Default] to set a selected exam mode as the default exam mode. The default exam mode is marked by a “√” in the top-left corner.

12.3 Measurement Preset

For details about Measurement Preset, see the [Advanced Volume].

12.4 Comment Preset

You can preset the custom comments library for current exam mode. The comments in the library are provided by the system or user-defined ones.

1. Select “<Setup>->[Comment Preset]” to enter Comment Preset:

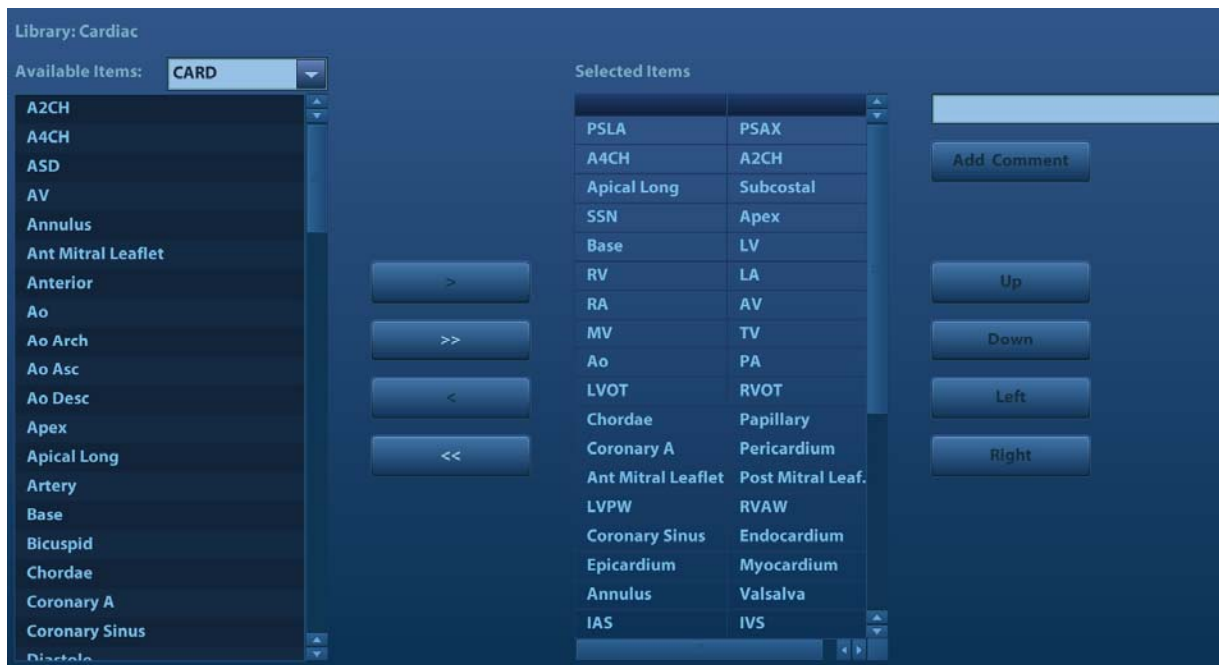

2. Add comments: directly enter user-defined comment texts, or select comment texts for the comment library.
 - Directly enter user-defined comment texts: posit the cursor in the field box above [Add Comment], enter the text comment through the keyboard, and then click [Add Comment]. Then the directly-entered comment will be added to the Available Items and Selected Items.
 - Select available items: First select a comment library in the drop-down list beside “Available Items”, all items will be displayed below “Available Items”.
 - Click [>] to add the item in Available Items on the left into Selected Items on the right.
 - Click [>>] to add all items in Available Items on the left into Selected Items on the right.
3. Change position of the selected items: select an item on the right side box and click [Up], [Down], [Left] or [Right] button to change the position of the item.
4. Withdraw or delete a user-defined comment:
 - Withdraw an item (from the library or user-defined) in the Selected Items list: Select an item in Selected Items list, and click [<] to withdraw it to the Available Items list. Click [<<] to withdraw all items in Selected Items.
 - Delete a user-defined item in the Available Items box: Select a user-defined item in the Available Items box, and click [<]. You can only delete the user-defined items rather than the items in the system library. After a user-defined item is deleted, it will not be available.
5. After you customize comments, click [Save] to confirm and exit the screen.

12.5 iWorks Preset

For details, see “Appendix C iWorks.”

12.6 Stress Echo Preset

For details, see “5.13.5 Maintenance and Protocol”.

12.7 DICOM Preset

For details, see “11.1 DICOM Preset.”

12.8 Network Preset

Parameters for transferring are set here. For details of local IP setting, see “Appendix A Wireless LAN”.

12.8.1 iStorage Preset

You can send exam data or images to the iStorage server and perform analysis using UltraAssist. For details about this feature, see the UltraAssist manual.

- The iStorage screen is as follows:

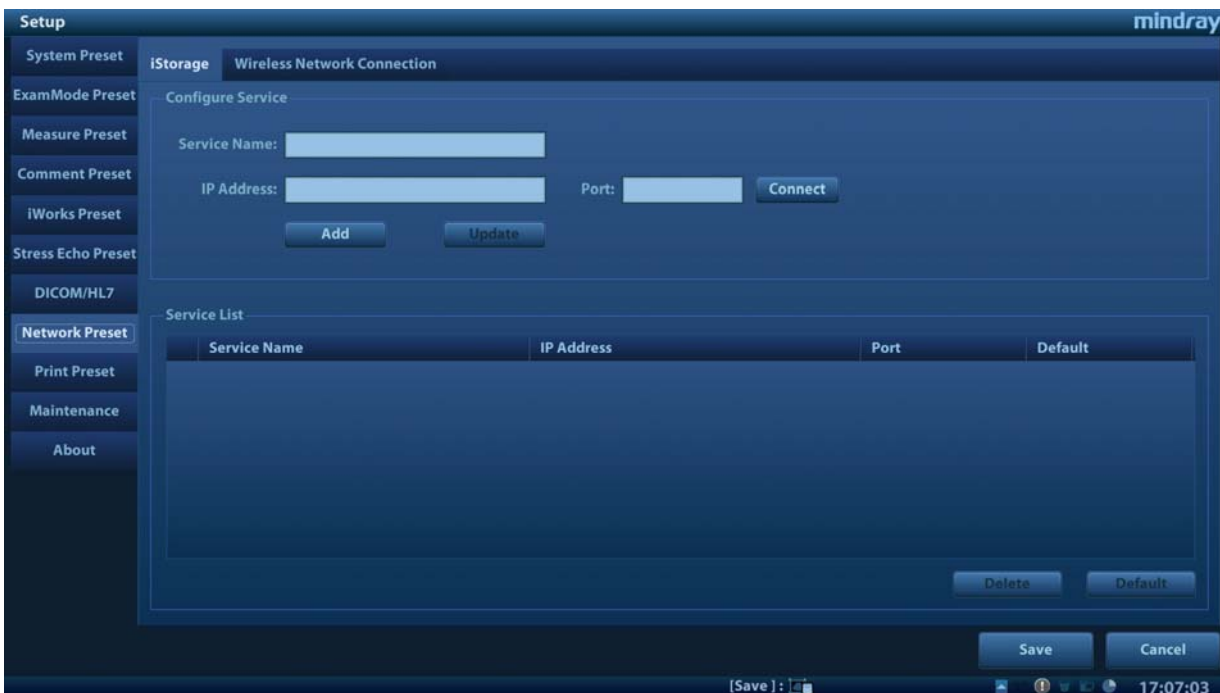

Name	Description
Service Name	The name of the iStorage service.
IP Address	IP address of the iStorage service device.
Port	Port for transmitting.
Connect	Click to verify connection.
Add	Click to add the Network service to the service list.

Name	Description
Update	To save the changed parameters.
Delete	Click to delete the selected service from the service list.

- Add an iStorage service
 1. Set the iStorage server properties as described above.
 2. Click [Add] to add the service to the Service list.
- Modify a network service
 1. Select the service to be updated in the service list.
 2. You can see properties in the Configure Service area.
 3. Modify the parameters and click [Update] to update the setting.

You can configure different type of iStorage services in different scenarios. See “12.1.7.2 Scene Preset Management” chapter for details.

12.8.2 Wireless Network Connection

You can set M9 system as a hotspot. When other devices (with available wireless network function) are connected to the M9 system, DICOM, iStorage and network print function can be implemented this way.

- Turn on hosted network function:
 1. Select [Wireless Network Connection] page in Network Preset screen.
 2. Confirm the Wi-Fi is enabled: you see [Disable Wifi] in the screen.
 3. Enter the name and password for this hotspot in the Hosted Network box.
 4. Click [Start] to enable the function.
 5. Use other devices to search and connect to this network.

12.9 Print Preset

This screen is used to set up the printer and image printing.

Click [Print Preset] in the preset menu to enter.

- Printer setting
 - The printer settings include print service and print driver.

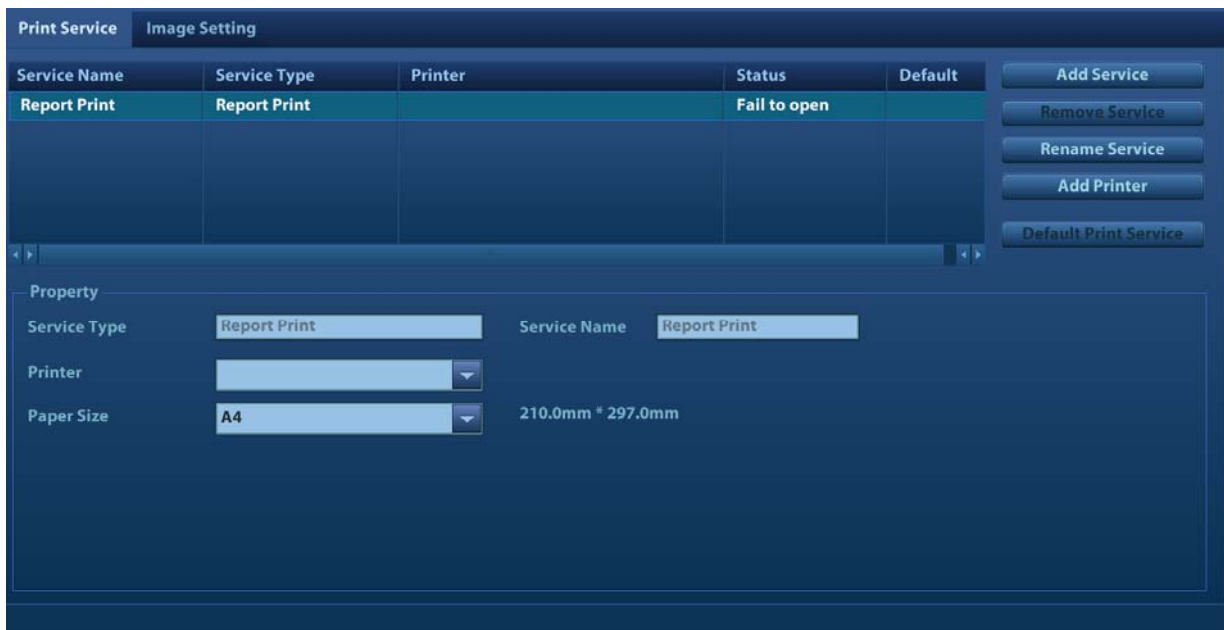

- Print Service Setting
 - Add Service: click to begin adding print services.
 - Remove Service: click to delete the selected print service.
 - Rename Service: click to rename the selected print service.
 - Default print service: click to set the selected print service as the default one.
 - Property: to preset print service properties.
- For details about adding printers, see “3.7 Installing a Printer.”

■ Image Settings

Click [Image Setting] to enter the page, you can set the brightness, contrast and saturation of image printing, or you can use the default values.

You can configure different type of print services in different scenarios. See “12.1.7.2 Scene Preset Management” chapter for details.

12.10 Maintenance

In the Setup menu, select [Maintenance] to enter the screen.

The [Maintenance] function is designed for you to import or export user data, restore factory setting and export log. You may also execute self-test and option installation/trial through the maintenance menu. If you require other maintenance functions, please contact Mindray Customer Service Department or sales representative.

12.10.1 Exporting Setup Data

This function is used to write all setup data of the system into a disk for backup. The format of the data file is .PDP.

You can select 3 types of preset data to export from the system:

- General module preset data: including “All Preset”, “Image Preset”, “iWorks Preset” and “DICOM/HL7” data.
- Exam mode related preset data, including all image setting, comment and body mark setting and measurement setting data.
- Scenario preset data, corresponding to the scenarios specific data.

Procedures:

1. Select the target module.

2. Click [Export] to open the [Export Data] screen.
3. Select the path to save the data.
4. Select the exported file and type as PDP and click [OK].

12.10.2 Importing Setup Data

This function is used to import the existing setup data to the setup data memory of the system. The system will reset and operate according to the setup preferences that were imported.

Procedures:

1. Click [Import] to open the Load Data screen.
2. Select the imported file.
3. Click [OK], a progress bar will appear and the setup data is imported to the specified path.
4. To restore the factory setup data, click [Load Factory] on the right side of the screen.

You can use [Export All], [Import All], or [Load Factory] at the bottom of the screen to export/import all setup data of the system or restore all factory setup data of the system. The operating methods are the same as those mentioned above.

12.10.3 Other Settings

Type	Item	Description
Load Factory		Local factory default settings.
Option		You can trial each option for 3 months at most. Each option can only be trialed once.
Setup	Self-Test	Perform system self-test and restart the machine.
	Export Log	Export the log.

If you have any questions, please contact the service engineer or your agent.

12.11 System Information

Click [About] on the Setup menu to enter the system information screen.

This screen displays the system software version and versions of other devices. You cannot edit the information, only view them. The information varies depending on the system configurations and version.

13 Probes and Biopsy

13.1 Probes

NOTE: For details of storage times and conditions for disinfected probes and brackets, refer to the Technical standard for Disinfection of Medical and Health Structures.

The system supports the following probes:

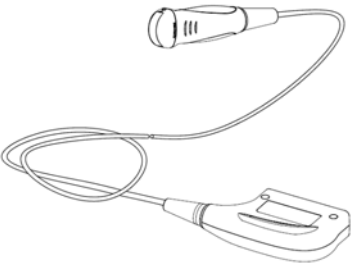
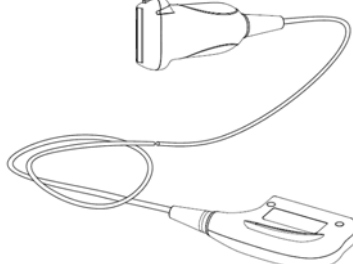
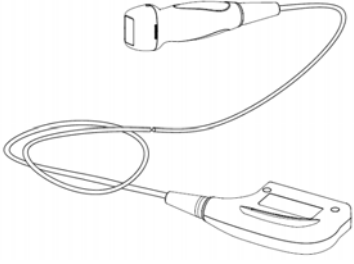
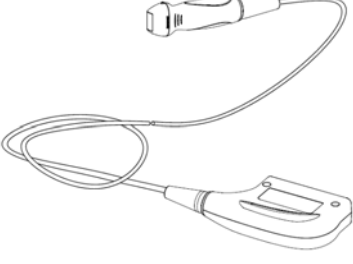
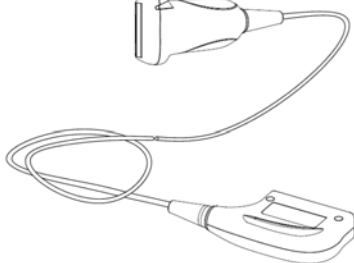
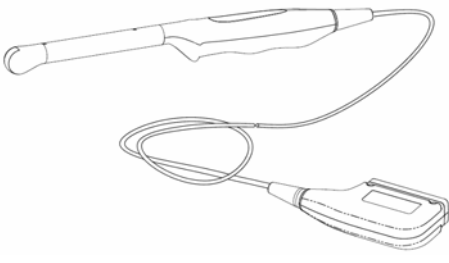
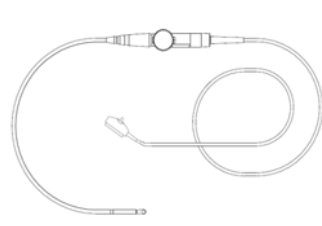
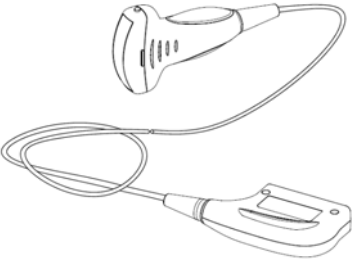
C11-3s		L12-4s	
SP5-1s		P10-4s	
L14-6Ns		V11-3Ws	
P7-3Ts		C5-1s	

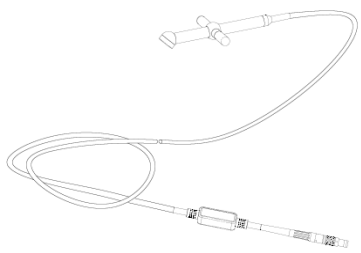
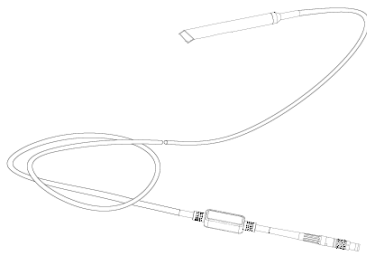
CW2s	 A line drawing of a CW2s probe. It features a long, thin cable with a coiled section. At one end is a small, cylindrical transducer head with a central opening. At the other end is a larger, rectangular connector with a locking mechanism.	CW5s	 A line drawing of a CW5s probe. It is similar in design to the CW2s probe, with a long cable and a coiled section. The transducer head is slightly larger and has a different shape, and the connector is also similar but with a distinct locking mechanism.
------	--	------	--

For details of probe P7-3Ts, see P7-3Ts Ultrasonic Transducer Operator's Manual.

13.1.1 Probe Functions by Part

The basic structures and corresponding functions of probes are basically the same. The following takes probe L14-6Ns as an example.

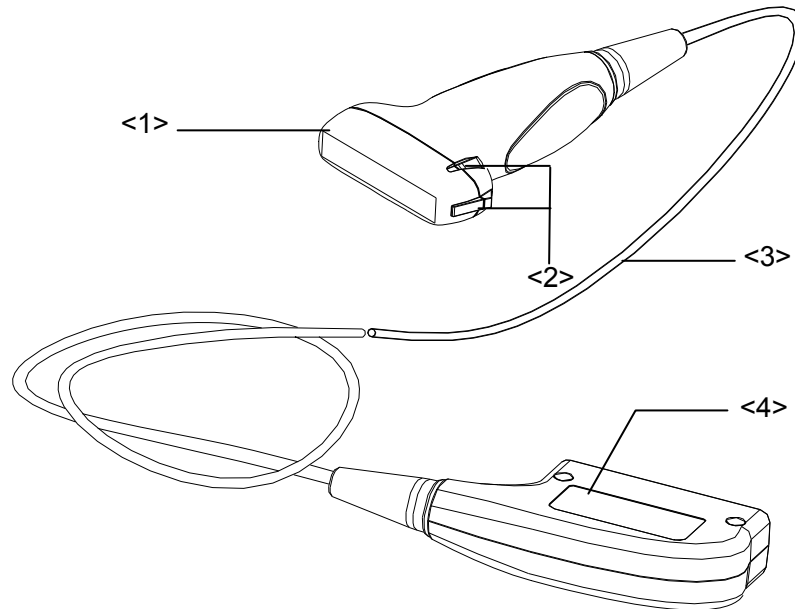

No.	Name	Function
<1>	Probe head	Converts the electrical signal to an ultrasonic signal, focusing the sound beams in a given direction while it receives the reflected ultrasonic signal and converts it to an electrical signal for transmission over the cable. The lens on the surface is the acoustic lens. Apply ultrasound gel to the acoustic lens for correct operation.
<2>	Needle-guided bracket fixing tabs and grooves	Provides mounting support for the needle-guided bracket.
<3>	Probe cable	Transmits electrical signals between the probe body and connector.
<4>	Probe connector	Connects the probe and cable to the ultrasound diagnostic system.
<5>	Lock handle	Locks the connector to the ultrasound diagnostic system.

Tip:

The probes' structure, marked <2> in the figure above, may vary depending on the corresponding needle-guided brackets.

13.1.2 Orientation of the Ultrasound Image and the Probe Head

The orientation of the ultrasound image and the probe are shown below. The “Mark” side of the ultrasound image on the monitor corresponds to the mark side of the probe. Check the orientation prior to the examination (using a linear probe as an example).

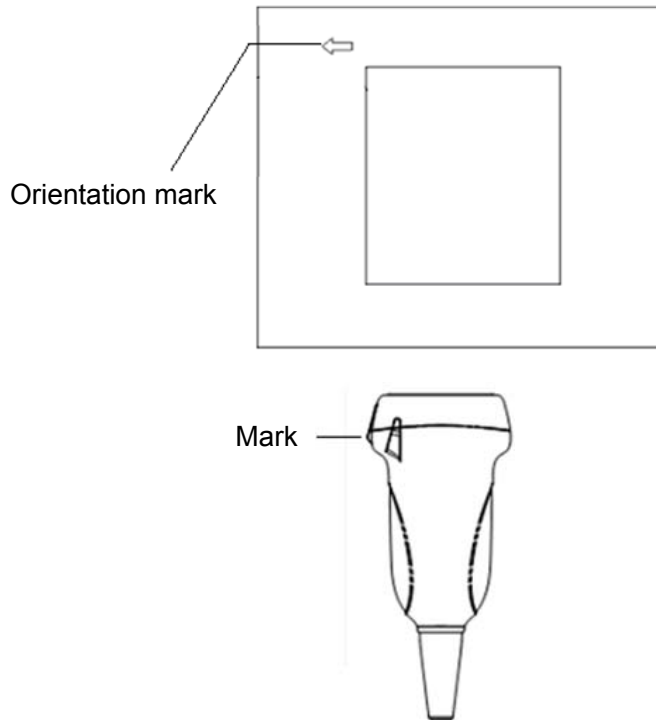

13.1.3 Operating Procedures

This section describes the general procedures for operating the probe. The proper clinical technique to use for operating the probe should be selected on the basis of specialized training and clinical experience.

Operating procedures (with biopsy function):

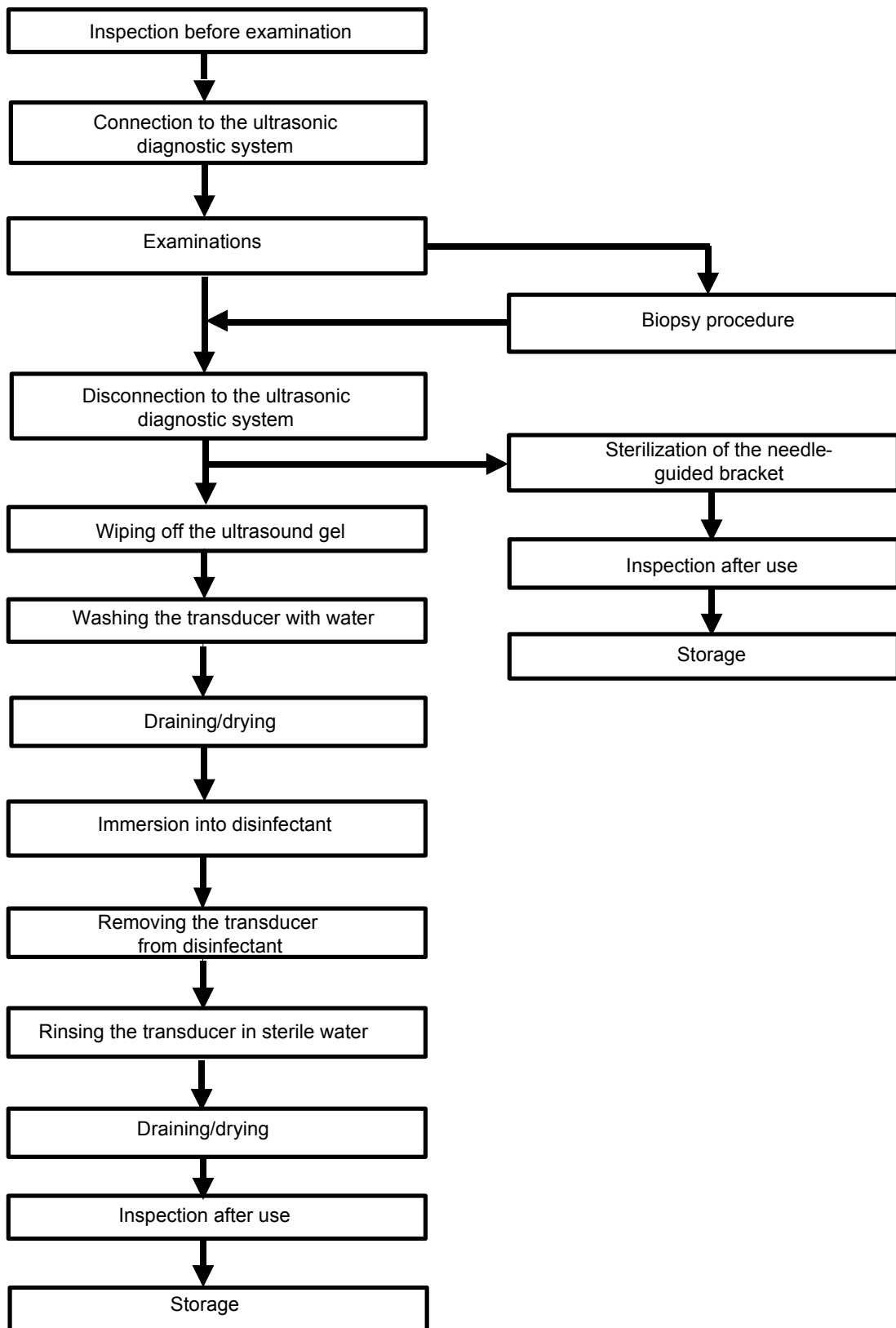

Operating procedures (with no biopsy function):

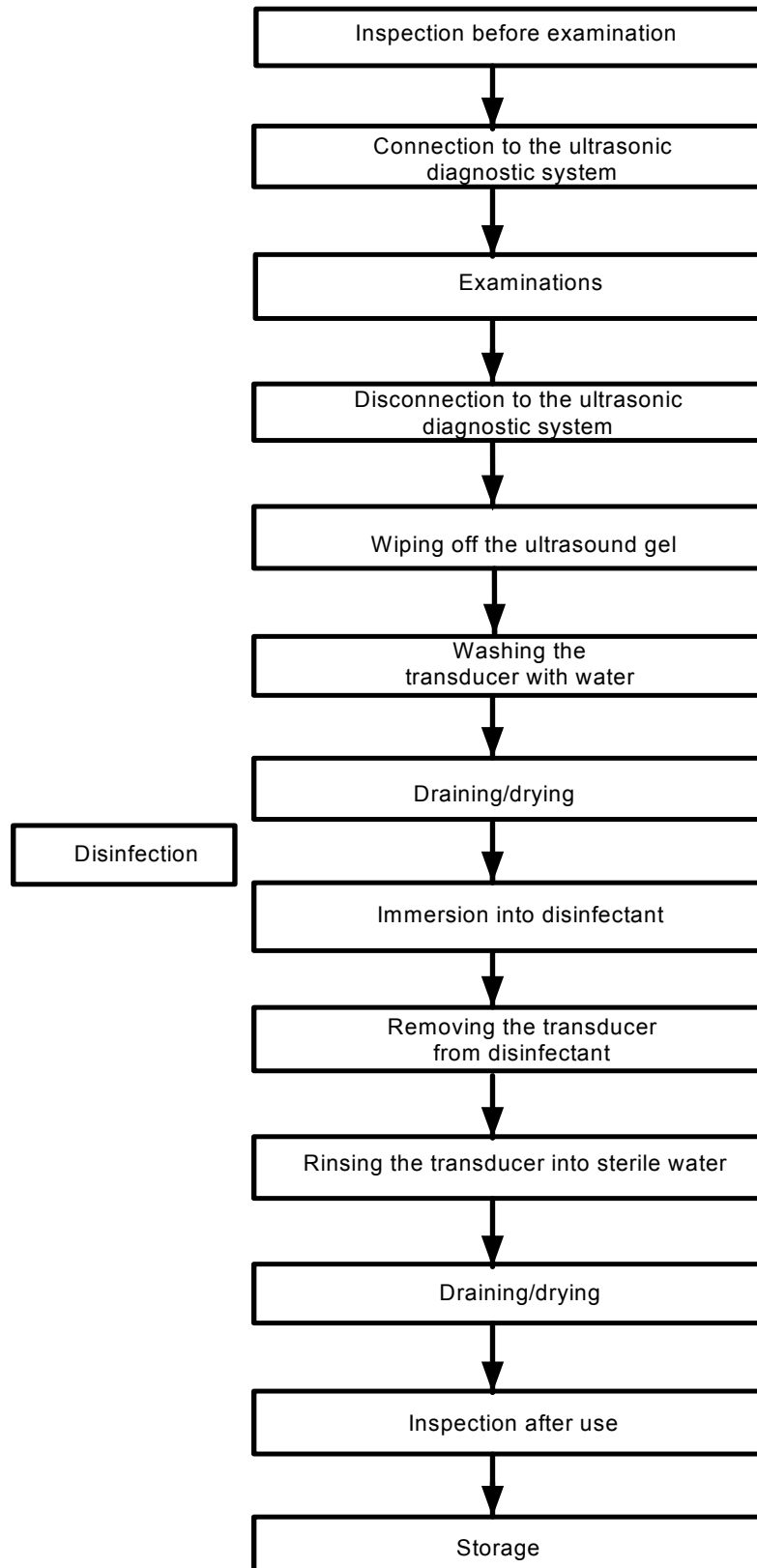

⚠️ WARNING: Disinfect the probe and sterilize the needle-guided bracket before and after an ultrasound-guided biopsy procedure is performed. Failure to do so may cause the probe and the needle-guided bracket to become sources of infection.

13.1.4 Wearing the Probe Sheath

A legally-marketed probe sheath must be installed over the probe before performing intra-cavitary and intra-operative examinations. Protective barriers may be required to minimize disease transmission. Probe sheaths are available for use in all clinical situations where infection is a concern.

To order probe sheaths, contact:

CIVCO Medical Instruments Co.

102 First Street South, Kalona, IA 52247-9589 USA Tel: 1-319-656-4447

E-mail: info@civco.com

<http://www.civco.com>

	<p>CAUTION: Be sure to cover the probe with a new (unused) probe sheath to prevent infection during examination. If the probe sheath packaging is open or broken, the probe sheath may not be sufficiently sterilized. DO NOT use the probe sheath in such circumstances.</p> <p>The cover contains natural rubber latex and talc that can cause allergic reactions in some individuals.</p> <p>DO NOT use an expired probe sheath. Before using a probe sheath, verify whether the term of validity has expired.</p>
---	--

Method (for reference only):

1. Place an appropriate amount of gel inside the sheath or on the probe acoustic lens. Poor imaging may result if no gel is used.
2. Insert the probe into the sheath. Be sure to use a proper sterile technique. Pull the cover tightly over the probe acoustic lens to remove wrinkles and air bubbles, taking care to avoid puncturing the sheath.

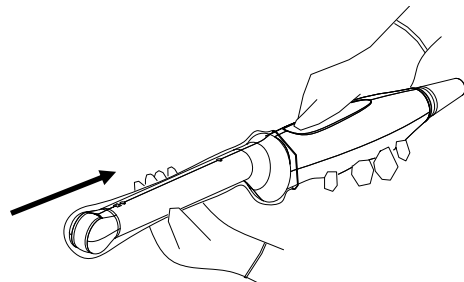
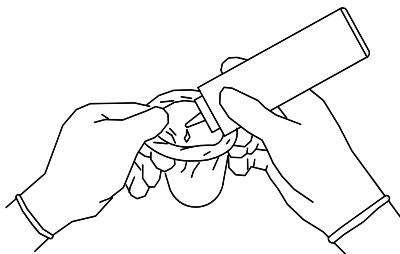

3. Secure the sheath with the enclosed elastic bands.
4. Inspect the sheath to ensure there are no holes or tears.

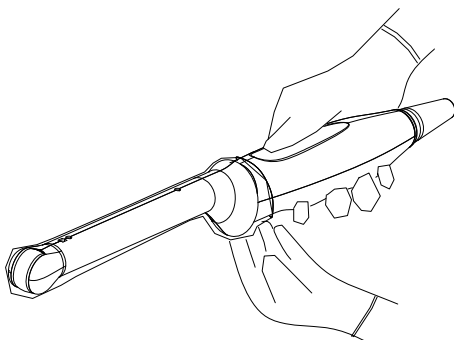

Refer to the following dimension table of all probes to choose the necessary probe sheath type.

Model	Length(mm)	Width(mm)	Height(mm)	Cable Length(mm)
C5-1s	76.7	109.6	28	2260±50
L12-4s	101.6	61	25.7	2260±50
P10-4s	83	29	20	1950±50
L14-6Ns	101.6	61	25.7	2260±50
V11-3Ws	318	25	21	1950±50
C11-3s	94	33	25	2260±50
CW2s	120	80	18	2260±50
CW5s	123	11	11	2050±50
SP5-1s	102	38	30	2260±50

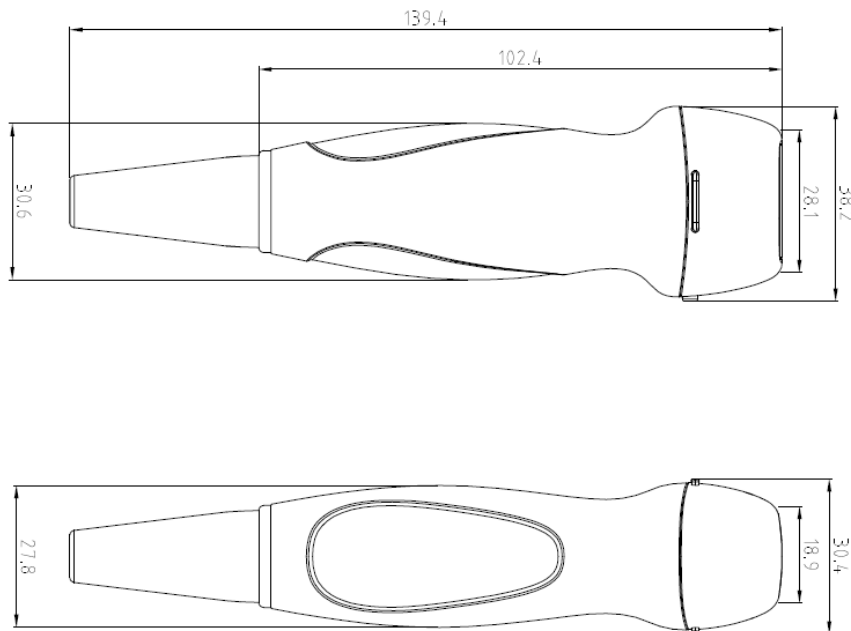

The above is a dimension illustration of the SP5-1s probe.

You can select the probe sheath according to the actual application situation.

13.1.5 Probes Cleaning and Disinfection

After completing each examination, clean and disinfect the probes as required. When biopsy procedures have been performed, be sure to sterilize the needle-guided bracket. Fail to do so may result in the probe and the needle-guided bracket to becoming sources of infection. Please follow the instructions in the manual for cleaning.



WARNING: Never immerse the probe connector into liquid such as water or disinfectant. Immersion may cause electrical shock or malfunction.

⚠ CAUTION:

When performing cleaning and disinfection of the probe to prevent infection, wear sterile gloves.



After disinfection, rinse the probe thoroughly with sterile water to remove all chemical residues. Chemical residues on the probe may be harmful to the human body.

No cleaning and disinfecting may result in the probe becoming a source of infection.

NOTE: After the examination, wipe off the ultrasound gel thoroughly. Otherwise, the ultrasound gel may solidify and degrade the image quality of the transducer.

DO NOT make the probe to become overheated (more than 55°C) during cleaning and disinfections. High temperature may cause the probe to become deformed or damaged.

Cleaning

Please refer to the instructions in the manual and follow your hospital policy and procedures for cleaning.

1. Disconnect the probe from the system.
2. Wear sterile gloves to prevent infection.
3. Wash the transducer with clean water or soapy water to remove all the foreign matters, or, wipe the transducer with a soft ethyl carbamate sponge. Avoid using a brush, because it may damage the transducer.
4. Dry the transducer using a sterile cloth or gauze after rinsing. Do not dry the transducer by heating it.

Disinfecting with Sprays

⚠ CAUTION:

Use protective eyewear when disinfecting using sprays.

1. Wear sterile gloves to prevent infection.
2. After you have finished cleaning, spray the transducer with a disinfectant. Follow the disinfectant manufacturer's recommended contact time and mode.
3. Remove any residue with a water-moistened soft cloth on the transducer.
4. Wipe off water on the transducer using sterile cloth or gauze after washing.

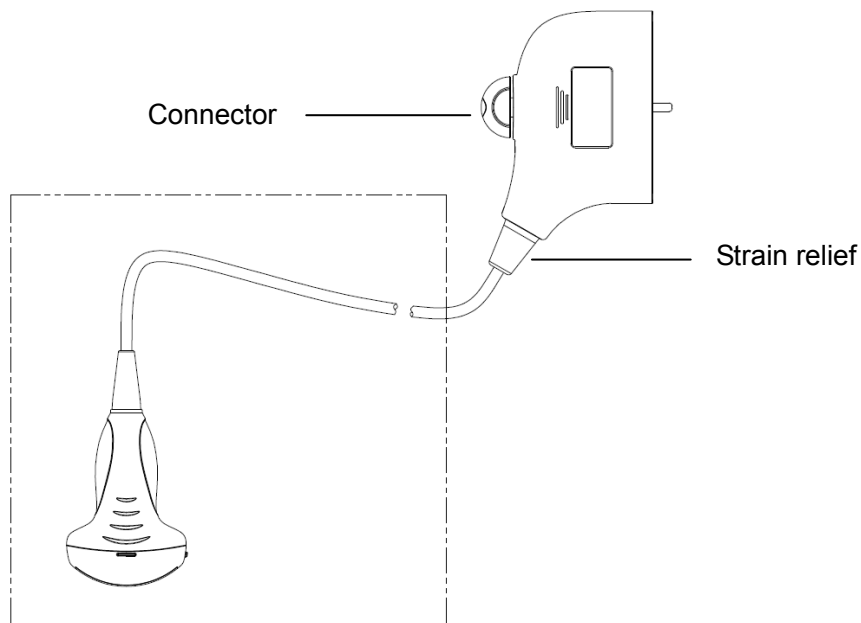

NOTE: Observe the graph here carefully to perform disinfection. Do not spray the strain relief on the connector end or the connector.

Disinfecting by Immersion

1. Wear sterile gloves to prevent infection.
2. Clean the transducer before disinfecting it. MINDRAY recommends the following solutions to disinfect the transducer.
 - Refer to the instructions provided by the chemical manufacturer concerning concentration of the disinfectant solution, method of disinfection and dilution and cautions during use. Do not soak the transducer connector or the cable near it into water or any solution.
 - Soak the transducer into the disinfectant solution for the shortest time the manufacturer recommends (for example, the shortest time recommended by the manufacturer for soaking Cidex OPA is 12 minutes).
 - Follow local regulations when selecting and using the disinfectant.
3. Rinse the transducer with plenty of sterile water (about 2 gallons) for at least 1 minute to remove all chemical residues on it. Or, follow the rinsing method recommended by the disinfectant manufacturer to rinse the transducer.
4. Wipe off the water on the transducer with sterile cloth or gauze after rinsing it. Do not dry the transducer by heating.

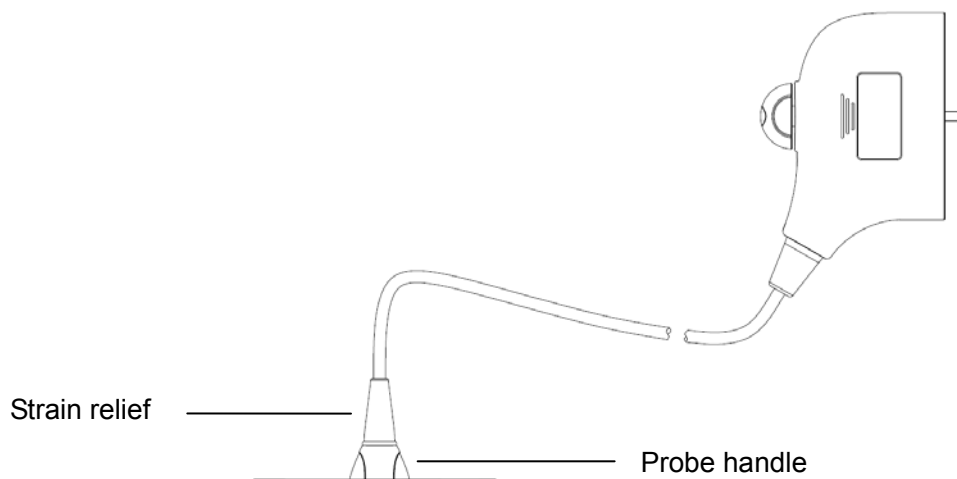

NOTE: Observe the graph here carefully to immerse the transducer. Only soak parts of the transducer below the strain relief.

Compatible Disinfectants

Manufacturer	Trade Name	Procedures	Type
Pharmaceutical Innovations, Inc.	T-Spray II	Please refer to the instructions provided by the manufacturer of the solution for details.	Spray*
Parker Laboratories Inc.	PROTEX™ DISINFECTANT SPRAY	Please refer to the instructions provided by the manufacturer of the solution for details.	Spray*
Metrex	MetriZyme	Please refer to the instructions provided by the manufacturer of the solution for details.	Solution*
ASP	Cidex Activated Dialdehyde Solution	Please refer to the instructions provided by the manufacturer of the solution for details.	Solution
ASP	Cidex OPA	Please refer to the instructions provided by the manufacturer of the solution for details.	Solution
Nanosonics Limited	Trophon Sonex-HL (Used with Trophon EPR Ultrasound Probe Disinfector)	Please refer to the instructions provided by the manufacturer of the solution for details.	Solution**
Tristel	Tristel solo	Please refer to the instructions provided by the manufacturer of the solution for details.	Spray***

- “*” denotes if the disinfectant is not applicable for following probes: P7-3Ts, CW2s, CW5s.
- “**” denotes if the disinfectant is not applicable for following probes: P7-3Ts, CW2s, CW5s, V11-3Ws
- “***” denotes if the disinfectant is only applicable for SP5-1s. No disinfectants listed above (except for Tristel solo) are applicable for SP5-1s.

See P7-3Ts accompanied manual for P7-3Ts disinfection.

Disinfection Type	Probe
Low level disinfection	C5-1s, L12-4s, P10-4s, L14-6Ns, C11-3s, CW2s, CW5s, SP5-1s
High level disinfection	P7-3Ts, V11-3Ws
High level disinfection (for biopsy exam)	V11-3Ws, L12-4s, L14-6Ns, SP5-1s, C11-3s

For details about additional infection control procedures or disinfection information, contact Mindray North America Customer Service [Tel: (1-800) 288 2121, (1-201) 995 8000].

13.1.6 Storage and Transportation

When all examinations for the session have been completed, confirm that the probe is in good condition. After disinfecting the probe, confirm that the probe is in good condition and stored in a suitable place.

1. To prevent the probe from being damaged, DO NOT store it where it may be exposed to:

- Direct sunlight or X-rays
- Sudden changes in temperature
- Dust
- Excessive vibration
- Heat generators

2. Store and transport the probe under the following ambient conditions:

- Ambient temperature: -20°C to 55°C
- Relative humidity: 30% to 95% (no condensation)
- Atmospheric pressure: 700 hPa to 1060 hPa

Store and transport the SP5-1s probe under the following ambient conditions:

- Ambient temperature: -20°C to 55°C
- Relative humidity: 20% to 95% (no condensation)
- Atmospheric pressure: 700 hPa to 1060 hPa

Store and transport the P7-3Ts probe under the following ambient conditions:

- Ambient temperature: -10°C to 45°C
- Relative humidity: 30% to 90% (no condensation)
- Atmospheric pressure: 700 hPa to 1060 hPa

3. When the probe is sent to the MINDRAY Customer Service Department or a sales representative for repair, be sure to disinfect it and keep it in the carrying case to prevent infection.

4. Sterilize the carrying case as necessary.

13.2 Biopsy Guide



WARNING:

The person performing biopsy procedures must understand diagnostic ultrasound thoroughly and have been adequately trained, otherwise the patient may suffer consequences.

In the situations listed below, the biopsy needle may fail to penetrate the target. Incorrect biopsy may cause various consequences for the patient.

- Using a needle-guided bracket other than that provided.
- Mounting the needle-guided bracket incorrectly.
- Using a biopsy needle that is unsuitable for the type of biopsy being performed.
- Using a biopsy needle that is unsuitable for the needle guide.

Before and after a biopsy procedure is performed, confirm that the needle-guided bracket is normal. Manually confirm that the parts of the needle-guided bracket do not slip or move from their proper positions. If the needle-guided bracket is used when parts are not securely and correctly installed, the patient may be injured. If an abnormality is found on the needle-guided bracket, immediately stop using it and contact the MINDRAY Customer Service Department or a sales representative.

DO NOT use a needle-guided bracket while scanning is performed. The needle may advance in an incorrect direction and possibly injure the patient.

Never perform a biopsy during image scanning.

DO NOT freeze an image while performing a biopsy procedure.

During biopsy procedures, the needle may deviate from the desired course due to tissue characteristics or the type of needle. In particular, needles with small diameters may deviate to a greater degree.

Disinfect the probe and sterilize the needle-guided bracket before and after each ultrasound-guided biopsy procedure is performed. Failure to do so may cause the probe and the needle-guided bracket to become sources of infection.

The needle mark displayed on the ultrasound image does not indicate the actual position of the biopsy needle. Therefore, it should only be used as a reference. Always monitor the relative positions of the biopsy needle during procedures.

Adjust the needle mark before the biopsy procedure is performed.

When performing biopsy procedures, only use sterile ultrasound gel that is certified as safe and manage the ultrasound gel properly to ensure that it does not become a source of infection.

When performing an operation involving biopsy, wear sterile gloves.

Image of the biopsy target and the actual position of the biopsy needle:

Diagnostic ultrasound systems produce tomographic plane images with information about particular thicknesses in the thickness direction of the probe. (That is to say, the information shown in the images consists of all the information scanned in the thickness direction of the probe.) Therefore, even though the biopsy needle appears to have penetrated the target object in the image, it may not actually have done so. When the biopsy target is small, dispersion of the ultrasound beam may lead to the image deviating from the actual position. Be aware of this.

The target object and biopsy needle appear in the image as shown in the figures below (for reference only):

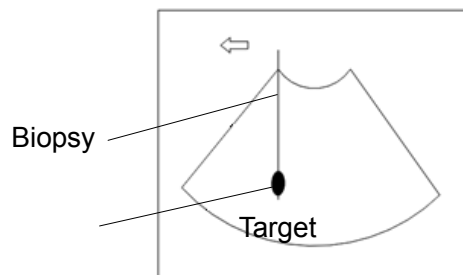

The biopsy needle appears to reach the target object in the image

Dispersion of the ultrasound beam

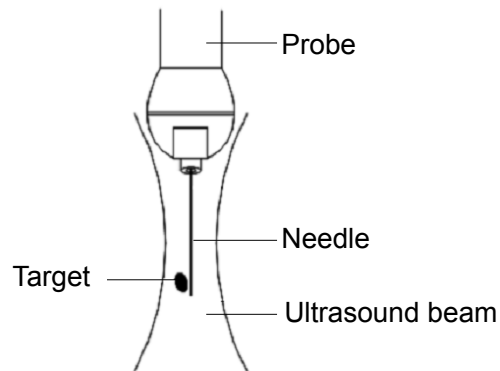

The biopsy needle may not have actually entered the target object even though it appears to have done so in the image. To avoid this, note the points below:

Do not rely only on the needle tip in the image. Pay careful attention to the fact that when the biopsy needle enters the target object or comes into contact with it, the object should shift slightly.

Before performing the biopsy, evaluate the size of the object and confirm whether the biopsy can be carried out.

13.2.1 Needle-Guided Brackets

Needle-guided brackets are available for purchase as optional accessories and are used in combination with the probe. Some probes have corresponding needle-guided brackets and needles. To order needle-guided brackets, contact the MINDRAY Customer Service Department or a sales representative.

For biopsy or treatment, ultrasound-guided biopsy procedures can be performed using the probe together with a needle-guided bracket (optional accessory) and a biopsy needle (provided by the user).

Names of Parts

This section describes the parts and corresponding functions of each needle-guided bracket. Here, we take a corresponding probe as an example.

■ NGB-004

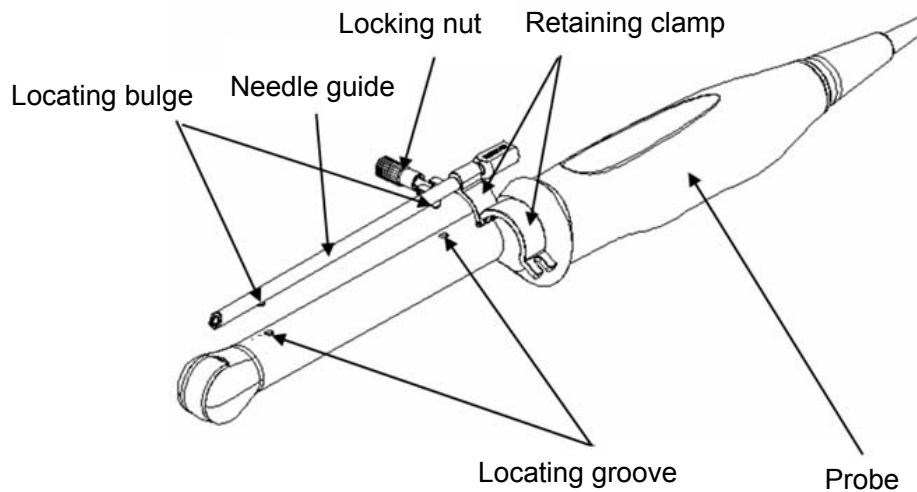

■ NGB-007

Metal/needle detachable needle-guided bracket:

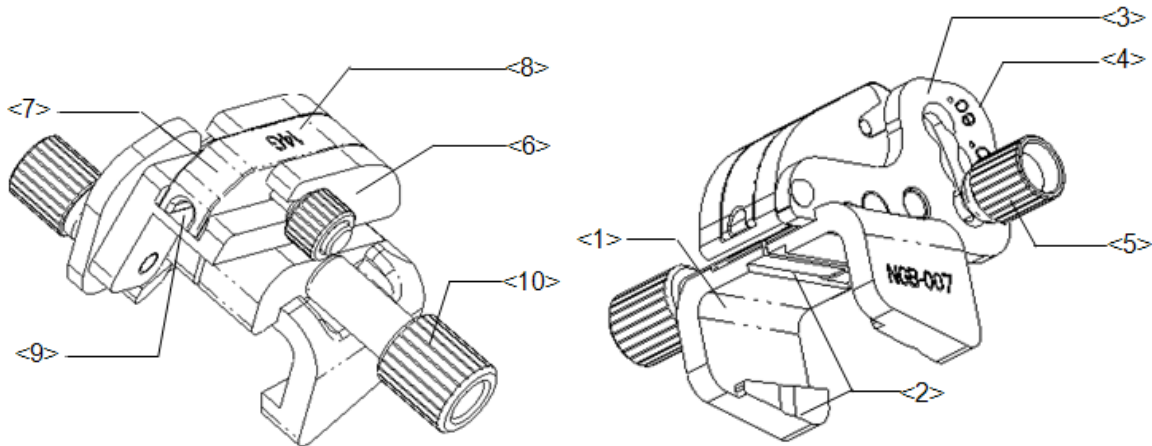

No.	Name	Description
<1>	Support for needle-guided bracket	Used for installing the needle-guided bracket on the probe.
<2>	Tab and groove for the needle-guided bracket	Corresponding to the tab and groove of the probe.
<3>	Angle-adjusting base	There are 3 types of angles available for adjustment.
<4>	Angle shift sign (40°, 50°, 60°)	Corresponding to the biopsy angle (40°, 50° and 60°).
<5>	Angle pinch nut	Used for fixing the angle lock at a chosen angle.
<6>	Angle block	Used for determining the angle of the biopsy. Different specifications of blocks can be used.
<7>	Guiding block	Used for installing biopsy needles. There are five guiding block specification for different biopsy needles.
<8>	Guiding block specification (14G)	Matched with the corresponding biopsy needle (14G).
<9>	Needle guide hole	Used for installing the biopsy needle.
<10>	Needle-guided bracket pinch nut	Used for locking the needle-guided bracket and the probe.

Plastic/needle detachable needle-guided bracket:

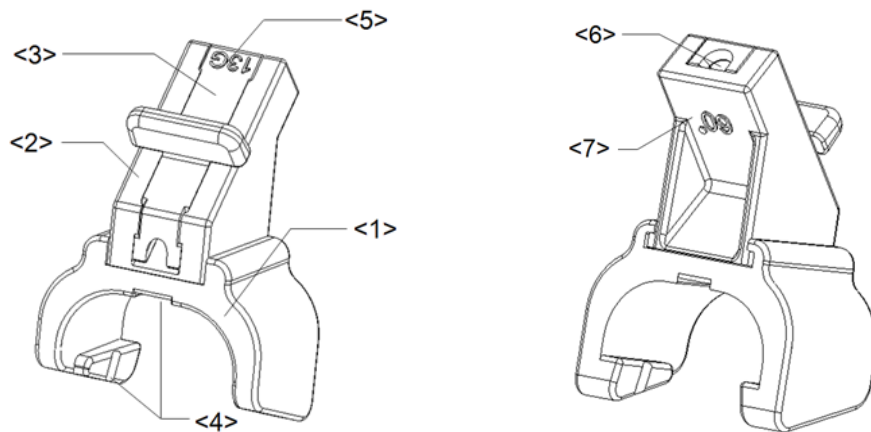

No.	Name	Description
<1>	Support for needle-guided bracket	Used for installing the needle-guided bracket on the probe.
<2>	Angle block	Used for determining the angle of the biopsy. There are three angle block specifications.
<3>	Guiding block	Used for installing biopsy needles. There are five guiding block specification for different biopsy needles.
<4>	Tab and groove for the needle-guided bracket	Corresponding to the tab and groove of the probe.
<5>	Guiding block specification (13G)	Matched with the corresponding biopsy needle (13G).
<6>	Biopsy needle guiding hole	Used for installing the biopsy needle.
<7>	Angle block specification (60°)	The corresponding biopsy angle is 60°.

■ NGB-011

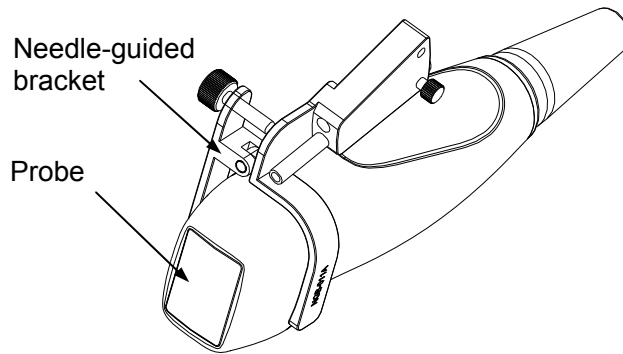
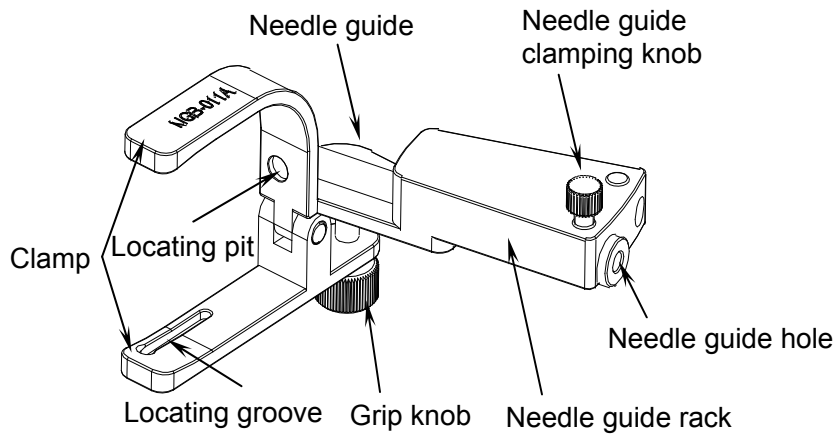

■ NGB-018

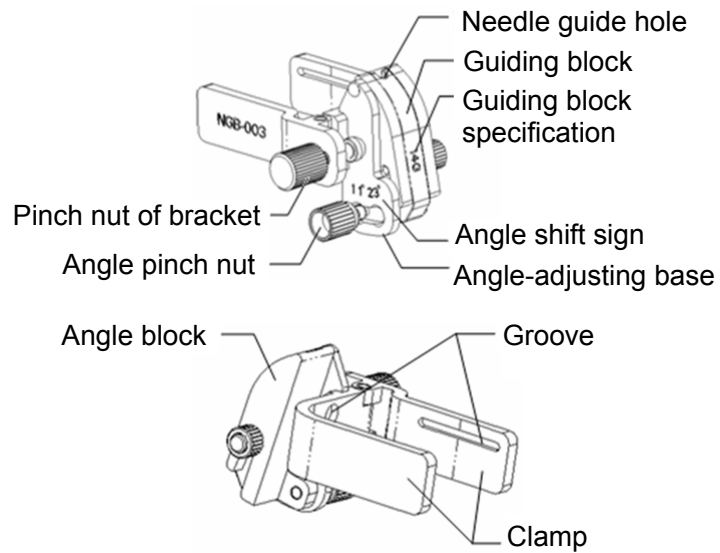

■ NGB-022

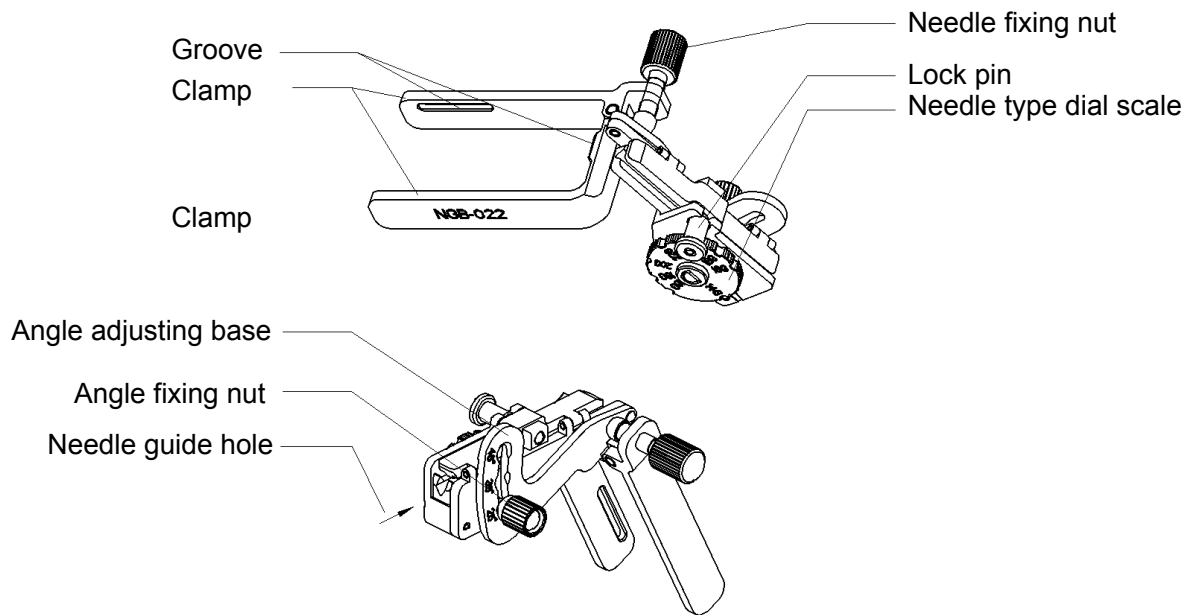

13.2.2 Basic Procedures for Biopsy Guiding

1. Select the correct needle-guided bracket and needle and install them properly. For details, see “13.2.3 Needle-Guided Bracket Inspection and Installation.”
2. Verify the biopsy guide line.
3. Press <Biopsy> to enter the biopsy.

Tip:

- If the current probe has no corresponding bracket, or the image is frozen and the guide line was hidden before the image was frozen, then you cannot enter the Biopsy menu.
- Before entering the Biopsy menu, the system will display the prompt “Please verify guidelines before biopsy.”

4. Use soft menu controls to select the bracket and guide line according to the actual situation.
5. In the Biopsy menu, click [Verify] to enter the Verify menu to verify the guide line. After verification, click [Save] to save the parameter setting. Then click [Exit] to return to the Biopsy menu.

Tip:

- If you changed the probe or needle-guided bracket during the biopsy, verify the guide line again.
- When exiting the Verify menu without saving, the system will display the prompt “Data have changed. Do you want to save the changes?” Click [Yes] to save the setting and return to the Biopsy menu.

6. Scan to locate the target. Center the target in the electronic guidezone path.
7. Direct the needle into the area of interest for specimen.
8. After extracting the biopsy sample is complete, gently remove the probe from the body.
To exit the Biopsy menu: press <Biopsy>.
9. Disassemble the items and properly dispose of these items as required.



DANGER

Failure to match the guidezone displayed to the guide may cause the needle to track a path outside the zone.

It is extremely important that when using the adjustable angle biopsy guides, the angle displayed on the screen matches the angle set on the guide, otherwise the needle will not follow the displayed guidezone and this could result in repeated biopsies or patient injury.

13.2.3 Needle-Guided Bracket Inspection and Installation

13.2.3.1 Inspection of the Needle-Guided Bracket

Be sure to perform inspections before and after using the needle-guided bracket. If an abnormality is found on the needle-guided bracket, immediately stop using it and contact the MINDRAY Customer Service Department or a sales representative.

1. Sterilize the needle-guided bracket before and after use.
2. Confirm that the needle-guided bracket is free from damage, deformation, stripping, malfunction, loose or missing parts.
3. Confirm that the needle-guided bracket is securely mounted in the correct position.

13.2.3.2 Installing the Needle-Guided Bracket

■ NGB-004

- (1) Put the sterile probe sheath on.

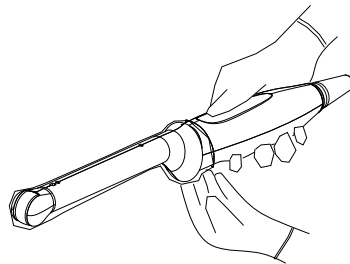

- (2) Open the retaining clamp, align the needle-guided bracket with the probe to align the locating bulge on the needle guide with the locating grooves on the probe, then turn the retaining clamp to align it with the probe (see the figure below).

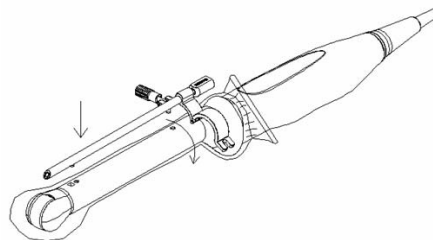

- (3) When the retaining clamp is turned to the correct position, the locking nut will lock the retaining clamp and the needle-guided bracket is then mounted in the correct position.

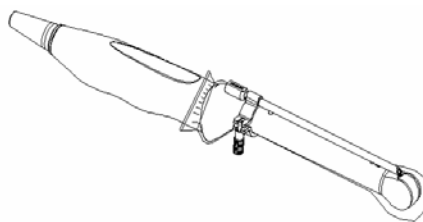

■ NGB-007

Metal/needle detachable needle-guided bracket:

- (1) Put the sterile probe sheath on.
- (2) Hold the probe in one hand, select the correct needle-guided bracket and hold it with the other hand. Match the groove and tab with the tab and groove of the probe respectively. Mount the bracket onto the probe.



- (3) Screw the pinch nut of the needle-guided bracket to ensure that the needle-guided bracket is properly installed on the probe.
- (4) Select a suitable guiding block and push it into the groove above the angle block, then clamp it tightly.



- (5) Screw the block's nut to secure the block.
- (6) Insert a biopsy needle with the same specification as that of the guiding block into the guiding block hole.

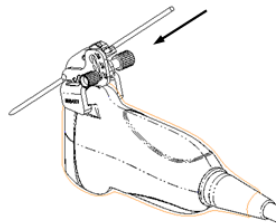

Plastic needle-guided bracket:

- (1) Put the sterile probe sheath on.
- (2) Hold the probe in one hand, select the correct needle-guided bracket and hold it with the other hand. Align the tab at the narrow end of the needle-guided bracket with the groove of the probe, then push the needle-guided bracket forward, so the tabs and grooves of the needle-guided bracket align with the grooves and tabs of the probe.

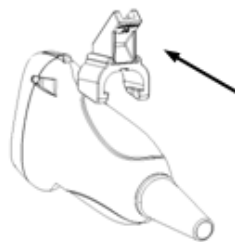

- (3) Check manually to confirm that the needle-guided bracket is securely installed on the probe.
- (4) Select a suitable guiding block and push it into the groove above the angle block, then clamp it tightly.

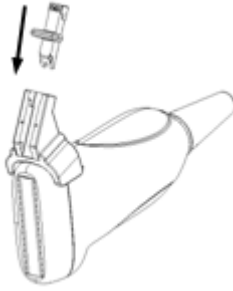

- (5) Insert a biopsy needle with the same specification as that of the guiding block into the guiding block hole.

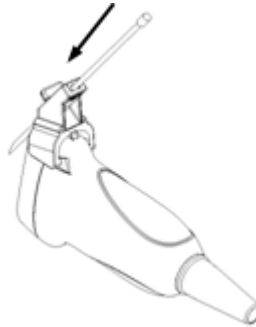

■ NGB-011

- (1) Connect the locating groove on the clamp with the two raised edges on the probe head and align the locating pit of the clamp with the convex point on the probe head.
- (2) Turn the grip knob at the tail of the needle-guided bracket tightly.

■ NGB-018

- (1) Put the sterile probe sheath on.
- (2) Select a suitable needle-guided bracket and match the groove to the tab of the transducer. Mount the bracket onto the transducer. The needle-guided brackets may be different from each other, but the methods are the same.



- (3) Screw the pinch nut of the needle-guided bracket to ensure that the needle-guided bracket is properly installed on the transducer.
- (4) Select a suitable guiding block and push it into the groove above the angle block.

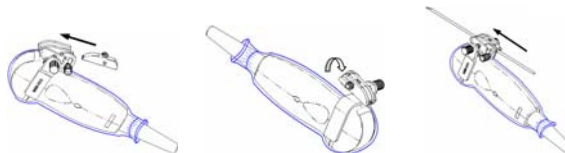

- (5) Screw the block's nut to secure the block.
- (6) Insert a biopsy needle with the same specification as that of the guiding block into the guiding block hole.

■ NGB-022

- (1) Put on the sterile transducer sheath.
- (2) Hold the transducer by one hand, select the proper needle-guided bracket, and hold it with the other hand. Match the groove of the bracket with the tab of the transducer. Amount the bracket onto the transducer.

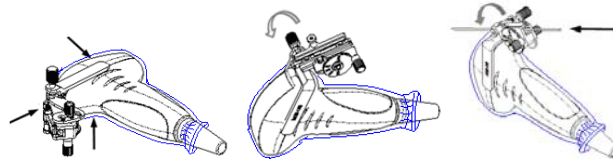

- (3) Screw the pinch nut of the needle-guided bracket to confirm that the needle-guided bracket is properly installed on the transducer.
- (4) Adjust the dial scale to the required needle type shift, and then screw the needle fixing nut to lock the dial scale. (To adjust the dial scale you have to loose the needle fixing nut first.)
- (5) Pull the lock pin and close the V-shaped cover to fix the lock pin in the groove of the needle type adjusting base, so as to install the needle into the guiding hole.



CAUTION:

Ensure that all guide parts are properly fixed prior to performing a biopsy.

13.2.4 iNeedle (Needle Visualization Enhancement)

During a biopsy, the metal needle attached to the probe pierces the tissue at a certain angle. Due to the needle's acoustic impedance, the ultrasonic beam cannot penetrate the metal needle and a reflecting boundary is formed. As in Figure 1, if the deflection angle is very large, the needle display is not clear.

In deflected ultrasound transmission, the beam direction is perpendicular to the needle direction and the reflection direction is the same as the needle, as shown in Figure 2, meaning the needle display in the ultrasound image is very clear. The system provides additional deflection transmission that is approximately perpendicular to the metal needle when the normal transmission (perpendicular to the transducer surface) is being processed. The deflection angle can be chosen by the user.

iNeedle is an option.

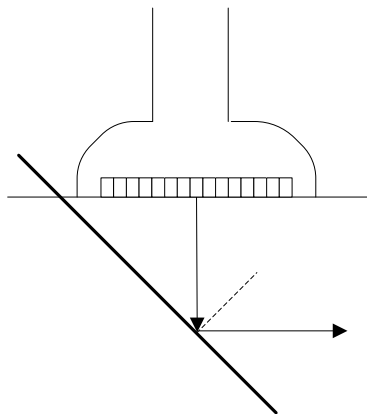

Figure 1

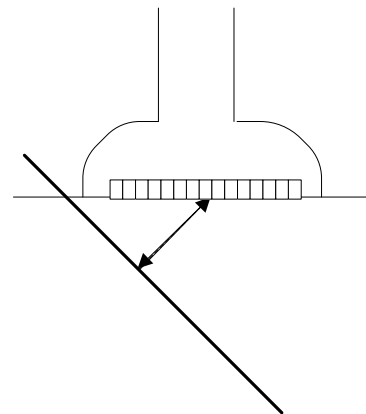

Figure 2

To enter/exit iNeedle

■ To enter iNeedle

Click the [iNeedle] item on the B mode soft menu or click [iNeedle] on the menu in the top-left part of the screen.

■ Open iNeedle in Biopsy status

1. Perform scanning and locate the target, press <Biopsy> to enter the screen.
2. Click [iNeedle] to be On to enter the status. Available adjusting parameters are displayed in the menu.

■ To exit iNeedle

Press the user-defined key or press to exit the status and enter B mode.

■ Best angle indication

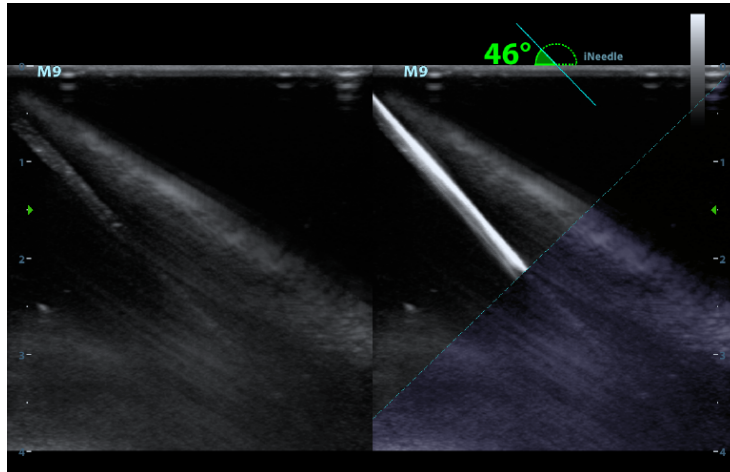

In iNeedle mode, recommended needle angle is given on the top of the screen. As shown in the above figure, the current recommended angle is 46° to the horizontal plane.

Needle Steer

Description This function adjusts the biopsy needle angle by changing the steer angle of the scan line. The iNeedle region changes correspondingly.

Operation Use [Needle Steer] on the soft menu to adjust the angle, in increments of 10° .
Or rotate the <Angle> knob, in increments of 2° .

B/iNeedle

Description This function is used to display the B image and iNeedle image synchronously.

Operation To turn the function on or off, click [B/iNeedle] on the soft menu.

Tip: iZoom (full-screen magnification) is available in iNeedle status.

Verify

To verify the biopsy guide line, see “13.2.5 Verifying the Biopsy Guide Line” chapter for details.

13.2.5 Verifying the Biopsy Guide Line

Adjusting the needle mark is necessary before each biopsy procedure.

1. Confirm that the needle-guided bracket has been installed securely in the correct position.
2. Prepare a container filled with sterile water.
3. Place the head of the probe in the sterile water and place a biopsy needle in the needle guide.
4. When the biopsy needle appears on the image, confirm that the biopsy needle is displayed at almost the same position as the selected needle mark.



WARNING: Prior to each biopsy procedure, be sure to verify the guide line.

If the needle is not consistent with the guide line, DO NOT perform the biopsy procedure.

NOTE: You can perform guide line verification on a single live B/C image, and all biopsy-irrelevant operations are forbidden.

Biopsy Guideline

Press <Biopsy> to enter Biopsy.

- Select the biopsy bracket angle/guide line

If the needle-guided bracket supports more than one biopsy angle, select the angle/guideline by clicking the [Kit: NGB-XXX-XX] on the soft menu (last two letters are angle or the guide line).

- Select the guide line dot size

Click [Dot Size] to select the dot size from Small, Medium and Big.

Tip:

- The guide line is a dotted line which consists of two kinds of dots. The distance between two dots is depth-dependent. Move the cursor over the big dot and a numeral, representing the biopsy depth, is displayed.
- The biopsy guidezone adjusts along with image adjustments, such as image inversion/rotations, zoom and depth changes.
- When the imaging depth and area are changed, the guide line is adjusted.

Verification

Click [Verify] in the Biopsy menu to open the Biopsy Verify menu, as shown in the figure below.

- Adjust the guide line position

Click [Position] to change the position of the guide line.

- Adjust the angle

Click [Angle] to change the guide line angle.

- Save the verified settings

After the position and angle of the guide line are adjusted, click [Save] and the system saves the current guide line settings. If biopsy is entered again, the displayed Position and Angle are the verified value.

- Restore the factory default settings

Click [Load Factory] and the position and angle of the guide line are restored to the factory default settings.

- Exit biopsy verify status

Click [Exit] and the system exits the guide line verification status.

NOTE: For biopsies performed with a biplanar probe, verification is performed on the first guide line. The other guide lines move together with the first one in parallel.

13.2.6 Removing the Needle-Guided Bracket

- NGB-004

Hold the probe in your left hand. Unscrew the locking nut with your right hand to open the retaining clamp, then raise the needle-guided bracket to separate the locating bulge from the locating grooves.

- NGB-007

Metal needle-guided bracket:

- (1) Loosen the guiding block's nut and slightly move the guiding block in the direction of the needle's tail.
- (2) Separate the residual part of the needle-guide bracket and the probe from the needle.
- (3) Loosen the bracket's pinch nut and remove the needle-guided bracket from the probe.

Plastic needle-guided bracket:

- (1) Slightly move the guiding block in the direction of the needle's tail.
- (2) Separate the residual part of the needle-guide bracket and the probe from the needle.
- (3) Remove the needle-guided bracket support from the probe.

- NGB-011

Hold the probe and the needle-guided bracket, then open the grip knob of the needle-guided bracket.

- NGB-018

- (1) Loosen the guiding block's nut and slightly move the guiding block in the direction of the needle's tail.

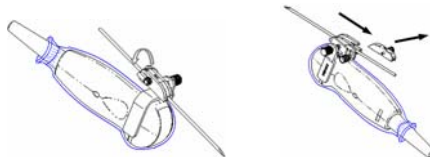

- (2) Separate the residual part of the needle-guide bracket and the transducer from the needle.
- (3) Loosen the bracket's pinch nut and remove the needle-guided bracket from the transducer.

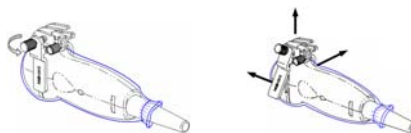

- NGB-022

- (1) Pull the lock pin and open up the V-shaped cover to expose the needle.

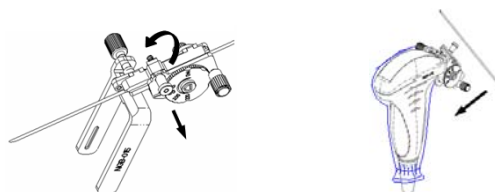

- (2) Separate the bracket and the transducer from the needle.
- (3) Screw the pinch nut to release the needle-guided bracket.

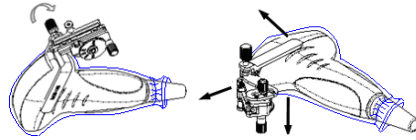

(4) Separate the bracket and the transducer.

13.2.7 Clean and Sterilize the Needle-Guided Bracket

Cleaning

Follow the cleaning instructions in the manual.

1. Wear sterile gloves to prevent infection.
2. Wash the needle-guided bracket with water or soapy water to remove all external material. Or, clean the needle-guided bracket with a urethane sponge.
3. After washing, dry the needle-guided bracket using sterile cloth or gauze.

High-level disinfection (applicable for Canada)

- Glutaraldehyde-based disinfectant:

Chemical name	Trade name	Procedures
Glutaraldehyde (2.4%)	Cidex Activated Dialdehyde Solution	Refer to the instructions provided by the solution manufacturer for details. Soak the transducer in the activated solution for 10 hours (20-25°C)

The plastic bracket NGB-007 can be disinfected using Cidex Activated Glutaraldehyde Solution at least 233 times (10 hours per time) before its safety and performance is affected.

- Refer to the instructions provided by the chemical manufacturer concerning concentration of the solution, and disinfection and dilution methods. Note that glutaraldehyde disinfectant solution requires an activating solution.
- Rinse the needle-guided bracket thoroughly with sterile water to remove all chemical residues from it.
- After rinsing, dry the needle-guided bracket with sterile cloth or gauze.

Sterilization

1. Wear sterile gloves to prevent infection.
2. Clean the needle-guided bracket before sterilizing it. MINDRAY recommends the following solution or sterilizing system for sterilizing the needle-guided bracket.
3. Follow local regulations when selecting and using disinfectant.

- Glutaraldehyde-based sterilant: (applicable for FDA region)

Chemical name	Trade name	Procedures
Glutaraldehyde (2.4%)	Cidex Activated Dialdehyde Solution	Refer to the instructions provided by the solution manufacturer for details. Soak the transducer in the activated solution for 10 hours (20-25°C)

The plastic bracket NGB-007 can be sterilized using Cidex Activated Glutaraldehyde Solution at least 233 times (10 hours per time) before its safety and performance is affected.

- Refer to the instructions provided by the chemical manufacturer concerning concentration of the solution, and disinfection and dilution methods. Note that glutaraldehyde disinfectant solution requires an activating solution.
- Rinse the needle-guided bracket thoroughly with sterile water to remove all chemical residues from it.
- After rinsing, dry the needle-guided bracket with sterile cloth or gauze.

■ STERRAD 100S low-temperature hydrogen peroxide gas plasma sterilization system

Chemical name	Trade name	Procedures
Hydrogen peroxide gas plasma	Hydrogen peroxide vapor	Refer to the instructions provided by the solution producer for details.

- Refer to the STERRAD 100S sterilizing system's instructions provided by the manufacturer for operation instructions and cautions.
- The STERRAD 100S low-temperature hydrogen peroxide gas plasma sterilization system is available for metal needle-guided brackets.

■ High-pressure steam sterilization (only applicable for metal guided brackets)
Autoclaving (moist heat) 121°C for 20 minutes.

NOTE: Repeated sterilization may degrade the safety and performance of the needle-guided bracket.

High-pressure steam/immersion sterilization does not affect a bracket's life duration. The life duration is affected by the bracket's daily application. Please check the appearance of the bracket before use.

13.2.8 Storage and Transportation

1. Do not use the carrying case for storing the needle-guided bracket. If the carrying case is used for storage, it may become a source of infection.
2. Between examinations, keep the needle-guided bracket in a sterile environment.
3. If the needle-guided bracket is sent to your MINDRAY representative for repair, be sure to disinfect or sterilize it and keep it in the carrying case to prevent infection.
4. Sterilize the carrying case as necessary.
5. Store or transport the needle-guided bracket under the following ambient conditions:
 - Ambient temperature: -20°C to 55°C
 - Relative humidity: 30% to 85% (no condensation)

13.2.9 Disposal

Be sure to sterilize the needle-guided bracket before disposing of it.
Contact your MINDRAY representative when disposing of this device.

13.3 Middle Line

Middle Line helps to locate and observe the focus point of lithotripsy wave during lithotripsy treatment. By means of providing information for the lithotripsy machine as well as a tool for watching the procedure of lithotripsy in real-time, you can adjust the intension and frequency of the lithotripsy wave through lithotripsy machine.

NOTE: This function in the ultrasound system is for lesion (stone) location and observation only. For details, please refer to lithotripsy machine accompanying manuals.

- To enter the mode: click [Middle Line] in the biopsy menu or preset a shortcut key for middle line function (for details, see “12.1.6 Key Configuration”). Press the user-defined key to turn on the function.

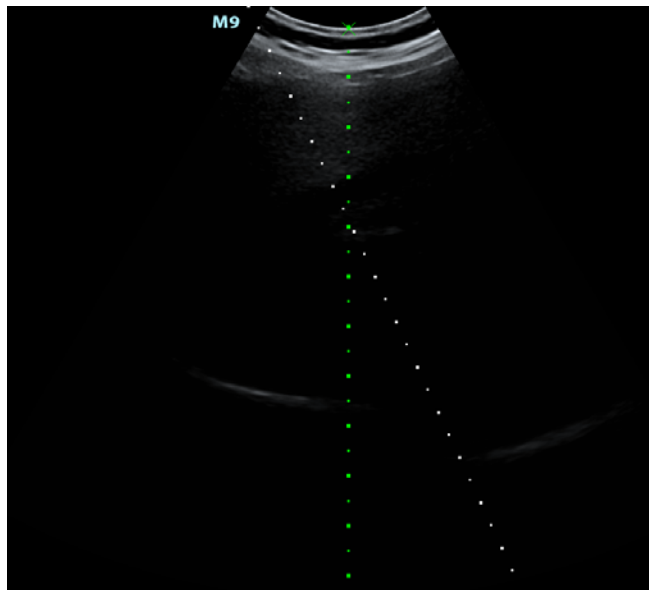

- The middle line is a vertical dotted line located in the middle of the screen, the position and direction of which cannot be changed.
- There is a mark icon of “x” located on the middle line which can be moved up and down along the line by rolling the track ball.
- To use the Middle Line function of the ultrasound system:
 - a) Use the trackball to change the mark position and by adjusting lithotripsy machine tools or patient posture to locate the stone center at the mark.
 - b) Read the depth of the mark by observing the depth caliper on the right of the image.
 - c) After the stone is located, refer to lithotripsy machine manuals to perform the lithotripsy.
- The depth of the mark is displayed in the image parameter area of the screen.

14 DVR Recording

NOTE: Strictly observe the procedures described here for performing recording and replaying operations. Failure to do so may result in data loss or system malfunction.

Set the PAL or NTSC during setup. This should be consistent with that on the DVR.

Accidental exposure to strong electromagnetic fields or mishandling of the video cassette may result in image and data loss. Check that the recording was successful as soon as possible. Mindray is not responsible for any data loss.

You can use the DVR device to record and replay videos and audios that can be stored in DVD disc or hard disc. For the detailed operation, please refer to the DVR accompanying operation manual.

DVR Recording

Recording is to record videos/audios arises from the examination and store them into DVD or hard disc of the DVR device.

Recording procedures with DVR:

1. Connect the DVR recorder to the ultrasound system and insert an available DVD disc, make sure there is memory in the hard disc.
2. Do output setting via “[Setup]→ [System Preset] → [General]”.
3. Start the ultrasound exam and acquire images.
 - To record: click begin recording related key on the DVR control panel to begin the recording.
 - To stop: click stop recording related key on the DVR control panel to stop the recording.

15 Acoustic Output

This section of the operator's manual applies to the overall system, including the main unit, probes, accessories and peripherals. This section contains important safety information for device operators pertaining to acoustic output and how to control patient exposure through use of the ALARA (as low as reasonably achievable) principle. This section also contains information regarding acoustic output testing and real-time output display.

Read this information carefully before using the system.

15.1 Concerns with Bioeffects

Diagnostic ultrasound is recognized as being safe. There have been no reports of injuries to patients caused by diagnostic ultrasound.

However, it cannot be stated categorically that ultrasound is 100% safe. Studies have revealed that ultrasound with extremely high intensity is harmful to body tissues.

Diagnostic ultrasound technology has made a great leap forward during the last several years. This rapid advance has generated concerns about the potential risk of bioeffects when new applications or diagnostic technologies become available.

15.2 Prudent Use Statement

Although there are no confirmed biological effects on patients caused by exposure from present diagnostic ultrasound instruments, the possibility exists that such biological effects may be identified in the future. Thus ultrasound should be used in a prudent manner to provide medical benefit to the patient. High exposure levels and long exposure times should be avoided while acquiring the necessary clinical information.

15.3 ALARA Principle (As Low As Reasonably Achievable)

The ALARA principle must be practiced when using ultrasound energy. Practicing ALARA ensures that the total energy level is controlled below a low enough level at which bioeffects are not generated while diagnostic information is being accumulated. The total energy is controlled by output intensity and total radiation time. The output intensity necessary for examinations differs depending on the patient and the clinical case.

Not all examinations can be performed with an extremely low level of acoustic energy. Controlling the acoustic level at an extremely low level leads to low-quality images or insufficient Doppler signals, adversely affecting the reliability of the diagnosis. However, increasing the acoustic power more than necessary does not always contribute to an increase in the quality of the information required for diagnosis, rather increasing the risk of generating bioeffects.

Users must take responsibility for the safety of patients and utilize ultrasound deliberately. Deliberate use of ultrasound means that the output power of ultrasound must be selected based on the ALARA principle.

Additional information regarding the concept of ALARA and the possible bioeffects of ultrasound is available in a document from the AIUM (American Institute of Ultrasound Medicine) entitled "Medical Ultrasound Safety."

15.4 MI/TI Explanation

15.4.1 Basic Knowledge of MI and TI

Mechanical Bioeffect and Thermal Bioeffect

The relationship of various ultrasound output parameters (frequency, acoustic pressure and intensity, etc.) to bioeffects is not fully understood at present. It is recognized that two fundamental mechanisms may induce bioeffects. One is a thermal bioeffect involving tissue absorption of ultrasound, and another is a mechanical bioeffect based on cavitations. Thermal Index (TI) gives the relative index of temperature increase by thermal bioeffect, and Mechanical Index (MI) gives the relative index of mechanical bioeffect. TI and MI indices reflect instantaneous output conditions. They DO NOT consider the cumulative effects of the total examination time. TI and MI models contain practical simplifications for complex bioeffect interactions. The operator must be aware that the actual worst case temperature rise may be up to several times higher than the displayed TI value.

■ MI (Mechanical Index)

The mechanical bioeffects are the result of compression and decompression of insonated tissues with the formation of micro bubbles that can be referred to as cavitations.

MI is an index that shows the possibility of cavitation generation based on acoustic pressure, and the value at which the peak rarefactional acoustic pressure is divided by the square root of the frequency. Therefore, the MI value becomes smaller when the frequency is higher or the peak rarefactional acoustic pressure is lower, and it becomes more difficult to generate the cavitations.

$$MI = \frac{P_r, \alpha}{\sqrt{f_{awf}} \times C_{MI}}$$

$$C_{MI} = 1 \text{ (MPa} / \sqrt{\text{MHz}} \text{)}$$

For the frequency 1 MHz and the peak rarefactional acoustic pressure 1 MPa, MI becomes 1. It is possible to consider MI as one threshold of cavitation generation. It is particularly important to keep the MI value low when both gases and soft tissues exist together, such as with lung exposure in cardiac scanning and bowel gas in abdominal scanning.

■ TI (Thermal Index)

The TI is determined by the ratio of the total acoustic power to the acoustic power required to raise the tissue temperature by 1°C. In addition, because the raise in temperature can be greatly different according to tissue structures, TI is divided into three kinds: TIS (Soft-tissue Thermal Index), TIB (Bone Thermal Index) and TIC (Cranial-bone Thermal Index).

TIS: Thermal index related to soft tissues, such as abdominal and cardiac applications.

TIB: Thermal index for applications such as fetal (second and third trimester) or neonatal cephalic (through the fontanel) applications, in which the ultrasound beam passes through soft tissue and the focal region is in the immediate vicinity of bone.

TIC: Thermal index for applications such as pediatric and adult cranial applications, in which the ultrasound beam passes through bone near the beam entrance into the body.

Although the output power is automatically controlled for the selected applications, high TI values should be kept to a minimum or avoided in obstetric applications. WFUMB (World Federation for Ultrasound in Medicine and Biology) guidelines state that temperature increases of 4°C for 5 minutes or more should be considered as potentially hazardous to embryonic and fetal tissue.

The smaller the MI/TI values, the lower the bioeffects.

15.4.2 MI/TI Display

TI and MI values are displayed in the top part of the screen in real time. The operator should monitor these index values during examinations and ensure that exposure time and output values are maintained at the minimum amounts required for effective diagnosis.

NOTE: If a value of MI or TI exceeds 1.0, the ALARA principle must be practiced.

The display precision is 0.1.

Display accuracy of MI is $\leq 14.7\%$, and TI is $\leq 28.5\%$.

15.5 Acoustic Power Setting

■ Acoustic power adjustment

Click the [A.power] to adjust the acoustic power percentage. Its value is displayed on the corresponding item, as well as at the top of the screen. The greater the acoustic power percentage, the greater the current acoustic output. When the image is frozen, the system stops transmitting acoustic power.

■ Default acoustic power setting

Selection of diagnostic applications is the most important factor in controlling ultrasound output. The permissible level of intensity of ultrasound differs depending on the region of interest. For fetal examinations, in particular, much care must be exercised.

Within this system, imaging setups can be created using the ultrasound output set by you.

Once you set the preset settings, the system's default setting values may be changed and invalid. The user is responsible for any change to the default settings.

■ Adjusting range

Initial power: 3.2% to 100%*

Definition of 100%: the maximum acoustic power of a probe determined by the increase in probe surface temperature in the selected mode and the acoustic power restrictions specified by the FDA.

Default settings of the acoustic power value refer to the best image quality for the probe. The larger the acoustic power value, the better the image quality.

In the M9 series products, to obtain optimum images for applications under the requirements of safety and ALARA principle, we set acoustic power default values in factory to be maximum 93.3% in OB1, OB2/3 and Fetal-Cardiac exam modes and maximum 96.6% in other modes for a better image quality. The user can make adjustments according to the imaging effect in practical use.

NOTE: This system automatically returns to the settings whenever changes are made to the values (when you turn on the power, switch between probes, press <End Exam>, or select OK or Cancel in the Setup menu). In the factory default settings, the Acoustic Output is limited to below 100%. Following the ALARA restriction, you are allowed to increase the acoustic power under FDA 510(k) Guidance-Track 3 limits and to set it in the image preset screen.

The system's acoustic output has been measured and calculated in accordance with IEC60601-2-37: 2007, FDA 510(K) GUIDANCE, Acoustic Output Measurement Standard for Diagnostic Ultrasound Equipment (NEMA UD-2 2004) and the Standard for Real-Time Display of Thermal and Mechanical Acoustic Output Indices on Diagnostic Ultrasound Equipment (AIUM and NEMA UD-3 2004).

15.6 Acoustic Power Control

A qualified operator may use the system controls to limit the ultrasound output and to adjust the quality of the images. There are three categories of system controls relating to output. They are:

- Controls that have direct effect on the output
- Controls that indirectly control the output
- Controls that are receiver controls

■ Direct controls

It is possible to control, if necessary, the acoustic output with the “A.power” item on the soft menu or the corresponding knob at the bottom of the soft menu. In this case, the maximum value of the acoustic output never exceeds an MI of 1.9 and an $I_{SPTA,3}$ of 720 mW/cm² in any mode of operation.

■ Indirect controls

The controls that indirectly affect output are the many imaging parameters. These are operating modes, frequency, focal point positions, overall depth and PRF.

The operating mode determines whether the ultrasound beam is scanning or non-scanning. Thermal bioeffect is closely connected to M mode, Doppler and Color mode. Acoustic attenuation of tissue is directly related to probe frequency. The focal point is related to the active aperture of the probe and beam width. For higher PRF (pulse repetition frequency), the more output pulses occur over a period of time.

■ Receiver controls

The receiver controls (for example, gain, dynamic range and image post-processing, etc.) do not affect output. These controls should be used, when possible, to improve the image quality before using controls that directly or indirectly affect output.

15.7 Acoustic Output

15.7.1 Derated Ultrasonic Output Parameters

In order to determine the relevant Ultrasonic Output Parameters, a method is used which allows for the comparison of ultrasound systems which operate at different frequencies and are focused at different depths. This approach, called “derating” or “attenuating”, adjusts the acoustic output as measured in a water tank to account for the effect of ultrasound propagation through tissue. By convention, a specific average intensity attenuation value is used, which corresponds to a loss of 0.3 dB/cm/MHz. That is, the ultrasound intensity will be reduced by 0.3 dB/MHz for every centimeter of travel from the probe. This can be expressed by the following equation:

$$I_{atten} = I_{water} \times 10^{(-0.3/10 \times f_c \times z)}$$

Where I_{atten} is the attenuated intensity, I_{water} is the intensity measured in a water tank (at distance z), f_c is the center frequency of the ultrasound wave (as measured in water) and z is the distance from the probe. The equation for attenuating pressure values is similar except that the attenuation coefficient is 0.15 dB/cm/MHz, or one-half the intensity coefficient. The intensity coefficient is double the pressure coefficient because intensity is proportional to the square of pressure.

The attenuation coefficient chosen, 0.3 dB/cm/MHz, is significantly lower than any specific solid tissue in the body. This value was chosen to account for fetal examinations. In early trimester ultrasound fetal examinations, there may be a significant fluid path between the probe and the fetus, and the attenuation of fluid is very small. Therefore the attenuation coefficient was lowered to account for this.

15.7.2 Limits of Acoustic Output

In accordance with the FDA Track 3 requirements, the derating (or attenuated) approach was incorporated into the FDA Acoustic Output Limits, as listed below. The maximum acoustic output level from any probe in any operating mode is expected to fall below these limits.

FDA Maximum Acoustic Output Limits for Track 3 (Attenuated Values)

Application	$I_{spta.3}$ (mW/cm ²)	$I_{sppa.3}$ (W/cm ²)	or	MI
Regions (except eyes)	≤ 720	≤ 190		

15.7.3 Differences between Actual and Displayed MI and TI

In operation, the system will display the Acoustic Output Parameters Thermal Index (TI) or Mechanical Index (MI) (or sometimes both parameters simultaneously) to the operator. These parameters were developed as general indicators of risk from either thermal or mechanical action of the ultrasound wave. They serve to indicate to the operator whether a particular system setting increases or decreases the possibility of Thermal or Mechanical effect. More specifically, they were designed to assist in the implementation of the ALARA principle. As an operator changes a given system control, the potential effect of the change in output is indicated. However, the Thermal Index is not the same as the raise in temperature in the body, for several reasons. First of all, in order to provide a single display index, a number of simplifying assumptions had to be made. The biggest assumption was the use of the attenuating formula described above, which is much lower than the actual value for most tissues within the body. Scanning through muscle or organ tissue, for example, will produce much higher attenuation than 0.3 dB/cm/MHz. Significant simplifications were also made for the thermal properties of tissue. Therefore, scanning through highly-perfused tissue, such as the heart or vasculature, will produce significantly less thermal effect than that suggested by the Thermal Index.

Similarly, the Mechanical Index was derived to indicate the relative possibility of mechanical (cavitation) effects. The MI is based on the derated peak rarefactional pressure and the center frequency of the ultrasound wave. The actual peak rarefactional pressure is affected by the actual attenuation caused by tissue in the path between the probe and the focal point. Again, all solid tissues within the body have higher attenuation than the prescribed 0.3 dB/cm/MHz value, and therefore, the actual peak rarefactional pressure will be lower. Further, the actual peak rarefactional pressure will change depending on the region of the body being scanned.

For these reasons, the TI and MI displays should only be used to assist the operator in implementing ALARA at the time of the patient examination.

15.8 Measurement Uncertainty

The total estimated measurement uncertainty (where the total uncertainty includes uncertainties in hydrophone response, measurement, calculation and positioning) are:

I_{spta}	28.5%
I_{sppa}	28.5%
Center frequency (f_c)	2%
Total power (W)	28.5 % (5.1% for Scan-mode and Combined-mode)
Rarefactional pressure (pr)	14.7%

15.9 References for Acoustic Power and Safety

1. "Bioeffects and Safety of Diagnostic Ultrasound" issued by AIUM in 1993
2. "Medical Ultrasound Safety" issued by AIUM in 1994
3. "Acoustic Output Measurement Standard for Diagnostic Ultrasound Equipment, Revision 3" issued by AIUM/NEMA in 2004
4. "Standard for real-time display of thermal and mechanical acoustic output indices on diagnostic ultrasound equipment, Revision 2" issued by AIUM/NEMA in 2004
5. "Information for Manufacturers Seeking Marketing Clearance of Diagnostic Ultrasound Systems and Transducers" issued by FDA in 2008
6. "Medical electrical equipment – Part 2-37: Particular requirements for the safety of ultrasonic medical diagnostic and monitoring equipment" issued by IEC in 2007

16 Guidance and Manufacturer's Declaration

The system complies with the EMC standard IEC60601-1-2: 2007.

 **WARNING:** The use of unapproved accessories may diminish system performance.

NOTE: Use of accessories, probes and cables other than those specified may result in increased emission or decreased immunity of the system.

The system or its components should not be used adjacent to or stacked with other equipment. If adjacent or stacked use is necessary, the system or its components should be observed to verify normal operation in the configuration in which it will be used.

The system requires special precautions regarding EMC and needs to be installed and put into service according to the EMC information provided below.

Other devices may interfere with this system despite meeting the requirements of **CISPR**.

Preventing conducted RF immunity. Due to technological limitations, the conducted RF immunity level is limited to 1 Vrms, conducted RF interference above 1 Vrms may lead to incorrect diagnosis and measurements. It is recommended to position the system away from sources of conducted RF noise.

Operation of system, in the case that the patient physiological signal is lower than the minimum amplitude or value specified in the product specifications, results may not be obtained (results can be obtained when the HR is in the range of 30-250 bmp or when the QRS wave amplitude is between 0.5-5 mv.)

Portable and mobile RF communication equipment can affect the system. See tables 1, 2, 3 and 4 below.

NOTE: If the system is operated within the electromagnetic environment listed in Table GUIDANCE AND MINDRAY DECLARATION—ELECTROMAGNETIC IMMUNITY, the system will remain safe and will provide the following essential performance:

- Imaging;
- Doppler audio and spectral display;
- Measurements;
- Printing using system printers;
- Patient information;
- Date/time information.

GUIDANCE AND MINDRAY DECLARATION—ELECTROMAGNETIC EMISSIONS

The system is intended for use in the electromagnetic environment specified below. The customer or user of the system must ensure that it is used in such an environment.

EMISSIONS TEST	COMPLIANCE	ELECTROMAGNETIC ENVIRONMENT- GUIDANCE
RF emissions CISPR 11	Group 1	The system only uses RF energy for its internal functions. Therefore, its RF emissions are very low and are unlikely to cause any interference with nearby electronic equipment.
RF emissions CISPR 11	Class B	The system is suitable for use in all establishments including domestic establishments and those directly connected to the public low-voltage power supply network that supplies buildings used for domestic purposes.
Harmonic Emissions IEC 61000-3-2	Class A	
Voltage Fluctuations/Flicker Emissions IEC 61000-3-3	Compliance	

GUIDANCE AND MINDRAY DECLARATION—ELECTROMAGNETIC IMMUNITY



The system is intended for use in the electromagnetic environment specified below. The customer or user of the system must ensure that it is used in such an environment.

IMMUNITY TEST	IEC 60601 TEST LEVEL	COMPLIANCE LEVEL	ELECTROMAGNETIC ENVIRONMENT-GUIDANCE
Electrostatic Discharge (ESD) IEC 61000-4-2	±6 kV contact; ±8 kV air	±6 kV contact; ±8 kV air	Floors should be of wood, concrete or ceramic tile. If floors are covered with synthetic material, the relative humidity should be at least 30%.
Electrical fast transient/burst IEC 61000-4-4	±2 kV for power supply lines ±1 kV for input/output lines	±2 kV for power supply lines ±1 kV for input/output lines	The mains power quality should be that of a typical commercial or hospital environment.
Surge IEC 61000-4-5	±1 kV line(s) to line(s) ±2 kV line(s) to earth	±1 kV line(s) to line(s) ±2 kV line(s) to earth	The mains power quality should be that of a typical commercial or hospital environment.
Voltage dips, short interruptions and voltage variation of power supply input voltage IEC 61000-4-11	<5% U_T (>95% dip in U_T) for 0.5 cycle 40% U_T (60% dip in U_T) for 5 cycle 70% U_T (30% dip in U_T) for 25 cycle <5% U_T (>95% dip in U_T) for 5 sec	<5% U_T (>95% dip in U_T) for 0.5 cycle 40% U_T (60% dip in U_T) for 5 cycle 70% U_T (30% dip in U_T) for 25 cycle <5% U_T (>95% dip in U_T) for 5 sec	The mains power quality should be that of a typical commercial or hospital environment. If continued operation during power mains interruptions is required, it is recommended to power the product from an uninterruptible power supply or a battery.
Power frequency (50/60 HZ) magnetic field IEC 61000-4-8	3 A/m	3 A/m	Power frequency magnetic fields should be at levels characteristic of a typical location in a typical commercial or hospital environment.

NOTE: U_T is the A.C. mains voltage prior to application of the test level.

GUIDANCE AND MINDRAY DECLARATION—ELECTROMAGNETIC IMMUNITY

The system is intended for use in the electromagnetic environment specified below. The customer or user of the system must ensure that it is used in such an environment.

IMMUNITY TEST	IEC 60601 TEST LEVEL	COMPLIANCE LEVEL	ELECTROMAGNETIC ENVIRONMENT-GUIDANCE
Conducted RF IEC 61000-4-6	3 Vrms 150 kHz - 80 MHz	1 Vrms	<p>Portable and mobile RF communication equipment should be used no closer to any part of system, including cables, than the recommended separation distance calculated from the equation applicable to the frequency of the transmitter. Recommended separation distance</p> $d = 3.5 \times \sqrt{P}$ $d = 1.2 \times \sqrt{P} \quad 80 \text{ MHz to } 800 \text{ MHz}$ $d = 2.3 \times \sqrt{P} \quad 800 \text{ MHz to } 2.5 \text{ GHz}$ <p>Where, P is the maximum output power rating of the transmitter in watts (W) according to the transmitter's manufacturer and d is the recommended separation distance in meters (m).</p> <p>Field strengths from fixed RF transmitters, as determined by an electromagnetic site survey, should be less than the compliance level in each frequency range.</p> <p>Interference may occur in the vicinity of equipment marked with the following symbol:</p> 
Radiated RF IEC 61000-4-3	3 V/m 80 MHz - 2.5 GHz	3 V/m	<p>Field strengths from fixed RF transmitters, as determined by an electromagnetic site survey, should be less than the compliance level in each frequency range.</p> <p>Interference may occur in the vicinity of equipment marked with the following symbol:</p> 

Note 1 At 80 MHz and 800 MHz, the higher frequency range applies.

Note 2 These guidelines may not apply in all situations. Electromagnetic propagation is affected by absorption and reflection from structures, objects and human body.

Field strengths from fixed transmitters, such as base stations for radio (cellular/cordless) telephones and land mobile radios, amateur radio, AM and FM radio broadcast and TV broadcast cannot be predicted theoretically with accuracy.

To assess the electromagnetic environment due to fixed RF transmitters, an electromagnetic site survey should be considered. If the measured field strength in the location in which the system is used exceeds the applicable RF compliance level above, the system must be observed to verify normal operation. If abnormal performance is observed, additional measures may be necessary, such as reorienting or relocating the system.

Over the frequency ranges 150 kHz to 80 MHz, field strengths should be less than 1 V/m.

RECOMMENDED SEPARATION DISTANCES BETWEEN PORTABLE AND MOBILE RF COMMUNICATION DEVICES AND THE SYSTEM

The system is intended for use in an electromagnetic environment in which radiated RF disturbance is controlled. The customer or the system user can help prevent electromagnetic interference by maintaining a minimum distance between portable and mobile RF communication equipment (transmitters) and the system as recommended below, according to the maximum output power of the communication equipment.

Rated Maximum Output power of Transmitter (W)	Separation Distance According to Frequency of Transmitter (m)		
	150 kHz - 80 MHz $d = \left[\frac{3.5}{f} \right] \sqrt{P}$	80 MHz - 800 MHz $d = \left[\frac{3.5}{f} \right] \sqrt{P}$	800 MHz - 2.5 GHz $d = \left[\frac{7}{f} \right] \sqrt{P}$
0.01	0.35	0.12	0.23
0.1	1.11	0.37	0.74
1	3.50	1.17	2.34
10	11.07	3.69	7.38
100	35.00	11.67	23.34

For transmitters at a maximum output power not listed above, the recommended separation distance in meters (m) can be determined using the equation applicable to the frequency of the transmitter, where P is the maximum output power rating of the transmitter in watts (W) according to the transmitter's manufacturer.

If system image distortion occurs, it may be necessary to position the system away from sources of conducted RF noise or to install an external power source filter to reduce RF noise to an acceptable level.

Note 1 At 80 MHz and 800 MHz, the separation distance for the higher frequency range applies.

Note 2 These guidelines may not apply in all situations. Electromagnetic propagation is affected by absorption and reflection from structures, objects and people.

Cable sample

No.	Name	Cable length (m)	Shield or not	Remarks
1	AC inlet cable for the main unit	2.5	Not shielded	/
2	AC inlet cable for the trolley	2.5	Not shielded	/
3	ECG Lead	1.4	Shielded	/
4	Foot-switch control cable	2.8	Not shielded	/
5	Probe cable	2.2	Shielding	/

- **Federal Communications Commission (FCC) Statement**

The wireless module has been tested and found to comply with the limits for a class B digital device, pursuant to Part 15 of the FCC rules. These limits are designed to provide reasonable protection against harmful interference in a residential installation. This equipment generates, uses and can radiate radio frequency energy and, if not installed and used in accordance with the instructions, may cause harmful interference to radio communications. However, there is no guarantee that interference will not occur in a particular installation. If this equipment does cause harmful interference to radio or television reception, which can be determined by turning the equipment off and on, the user is encouraged to try to correct the interference by one or more of the following measures:

- Reorient or relocate the receiving antenna.
- Increase the separation between the equipment and receiver.
- Connect the equipment into an outlet on a circuit different from that to which the receiver is connected.
- Consult the dealer or an experienced radio/TV technician for help.

17 System Maintenance

Routine system maintenance shall be carried out by the user. System maintenance after the warranty has expired is the full responsibility of the owner/operator.

The responsibility for maintenance and management of the product after delivery resides with the customer who has purchased the product.

If you have any questions, please contact the Mindray Customer Service Department or a sales representative.

 **WARNING:** Only an authorized Mindray service engineer can perform maintenance which is not specified in this operator's manual.

For the sake of system performance and safety, perform periodical checks of the system.

17.1 Daily Maintenance

You are responsible for daily maintenance.

17.1.1 Cleaning the System

 **WARNING:** Before cleaning the system, be sure to turn off the power and disconnect the power cord from the outlet. Cleaning the system while the power is "On" may result in electric shock.

DO NOT directly spray solution onto the monitor, system control panel or hard surfaces that are under pressure or pumped. Ingress fluid leakage into the monitor or system can damage the monitor or system, causing possible electric shock or system failure.

 **CAUTION:** Do not spill water or other liquids into the system while cleaning. This may result in malfunction or electric shock.

NOTE: DO NOT use hydrocarbon glass cleaner or cleaner for OA (Office Automation) equipment to clean the monitor. These substances may cause deterioration of the monitor.

Clean the control panel periodically, otherwise the button may become blocked with dirt and the system will buzz while the button has no effect.

- Cleaning the probe
 - Tools: mild soapy water, soft dry cloth, soft brush
 - Method:
 - a) Wipe away dust attached to the surface of the probe head, connector and cable.
 - b) Use a soft brush to gently brush away dust from inside the probe connector.

- c) Remaining stains or dust attached to the surface of the cable or connector should be wiped away using a cloth with a little soapy water and then air dried.

NOTE: Do not use a wet cloth to clean the probe connector.

■ Cleaning the probe cable

- a) Use a soft dry cloth to wipe away stains from the probe cable.
b) If the stains are difficult to remove, use a soft cloth dipped in a mild detergent and then let the cable air dry.

■ Cleaning holders

- Tools: soft dry cloth, soapy water, soft brush
- Method:

The surface of the power button should be cleaned with a soft dry cloth. Remaining stains should be wiped away using a cloth with clean or soapy water (NOTE: the cloth should not be made too wet, as this may cause electric shock) and the surface left to air dry.

- a) Use a soft dry cloth to wipe away dust attached to the inside, outside and gaps in the probe holder or gel holder. Use a soft brush to brush away dust or stains from the small intra-cavity probe holder or its gap.
b) Remaining stains on the inside and outside of the holder should be wiped away using a cloth with a little soapy water and then air dried.
c) Gel warmer: remove the gel warmer after pulling out the power supply cable. Use a soft dry cloth to wipe away dust attached to the inside and outside, then brush away dust in the gel warmer or brush stains with a little soapy water and then air dry.

■ Cleaning the display

- Tool: soft dry cloth, clean or soapy water
- Method:

The surfaces of the display should be cleaned with a soft dry cloth. Remaining stains should be wiped away using a cloth with a little clean or soapy water and then air dried.

■ Cleaning the trackball

- Tools: paper, dry cloth, mild soapy water
- Method:

For the stable performance of the system, you should perform periodical cleaning for the trackball. A dumb cursor may be resulted from dirt inside the trackball.

(1) Disassembling:

Rotate the trackball clamp ring 35 degrees anticlockwise. When the clamping ring lifts, remove the clamping ring and trackball. You can draw out the ball with the help of adhesive tape. See the figures below.

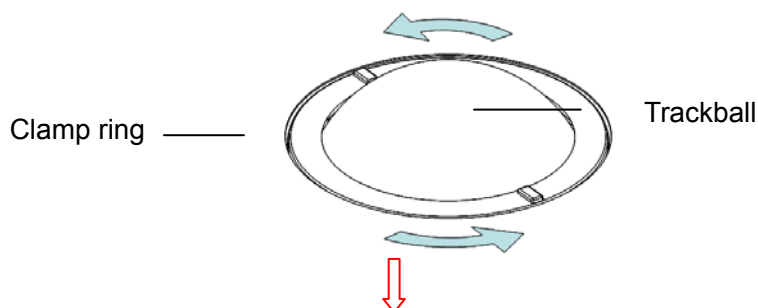

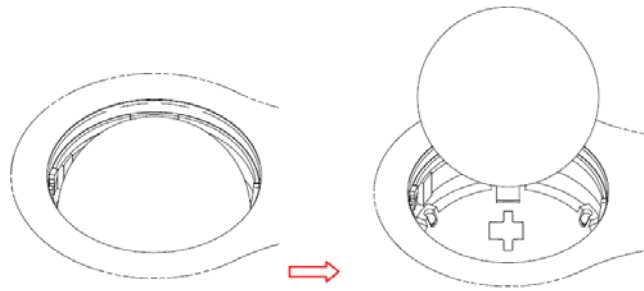

(2) Cleaning:

Clean the two long shafts, the bearing and the rotary ball with clean soft dry cloth or paper.

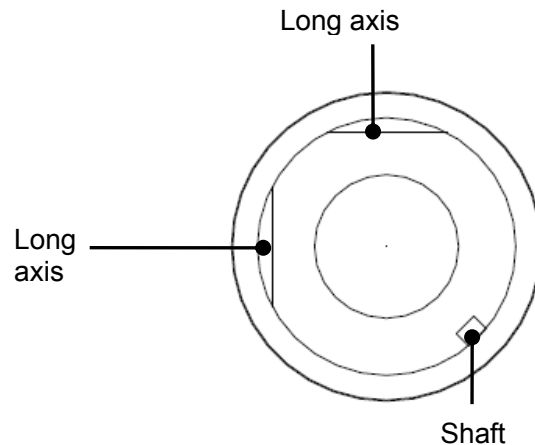

(3) Installing

Put back the ball, align the buckle with gap of the front cover, press the clamp ring with both hands and rotate it 35 degrees clockwise to click the buckle. At this moment, the clamp ring cannot be moved any further, it indicates that the clamp ring clicks in position. See the figure below.

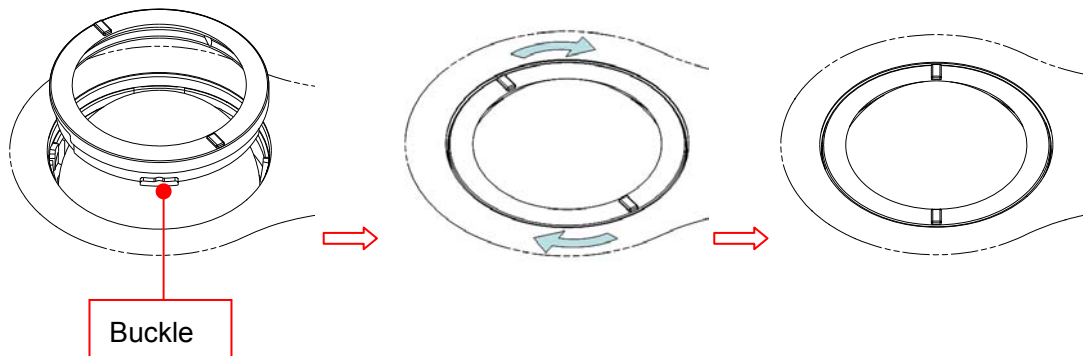

■ Cleaning the main panel

- Tools: soft dry cloth, soapy water
- Method:

Use a soft dry cloth to clean the surface of the control panel (including the keystrokes, encoders and sliders). If the control panel is dirty, moisten the soft cloth with a little mild soapy water and wipe away any stains. Use another soft dry cloth to remove any moisture and allow all hard surfaces to completely air dry. If the control panel is difficult to clean, disassemble the encoder caps first and then clean it with mild soapy water.

NOTE: The keyboard on the control panel should be cleaned periodically, otherwise the keys may become blocked with dirt and when the buzzer rings the keys will not work.

■ Cleaning the cover

- Tools: soft dry cloth, soapy water
- Method:

Use a soft dry cloth to clean the system's cover. If the system is dirty, moisten the soft cloth with mild soapy water, wipe away any stains, then air dry.

CAUTION: Please clean all the system's dustproof covers periodically (once per month). Failure to do so may result in system damage. Cleaning times can be increased when the system is used in the open air or somewhere more dusty.

NOTE: Use a soft brush to brush away dust attached to all visible sockets or interfaces (such as probe sockets, sockets or interfaces in the IO panel and power supply panel). Do not use a cloth and water.

■ Dust-proof cover cleaning

Include system dust-proof mesh of main unit and dust-proof mesh of trolley.

- Tool: soft brush
- Method:

Disassemble dust-proof cover before cleaning.

Dust-proof mesh of trolley: open the clasp of dust-proof mesh. Push the dust-proof mesh towards the arrow to let it fall off completely from dust-proof slot. Then, take it out.

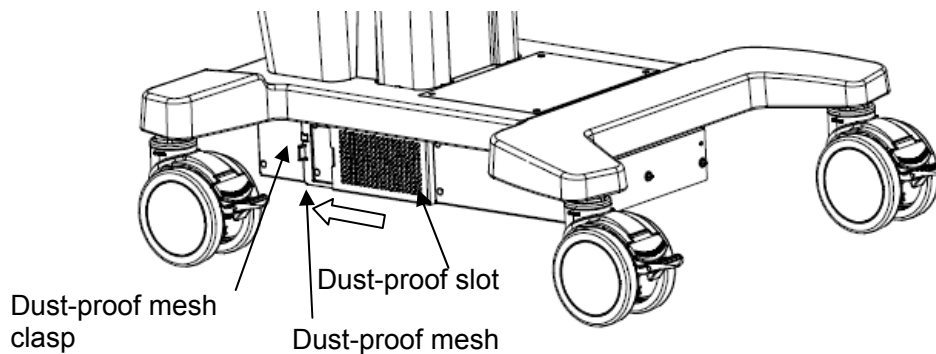

Dust-proof mesh of main unit: take out the dust-proof mesh of the main unit.

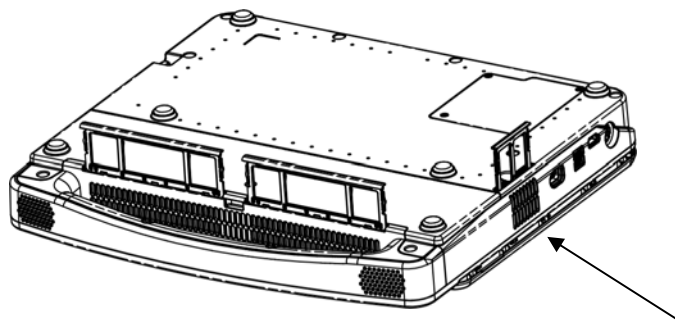

**CAUTION:**

Please clean all dust-proof covers of the system periodically (1 time per month); otherwise, system damage may result. Cleaning times can be increased when the system is used in the open air or somewhere dust is more.

■ Cleaning the peripherals

Carry out cleaning maintenance according to your actual peripheral configuration. Items which are not configured can be skipped.

Content	Description
Color and B/W video printer	Wipe away dust or stains on the printer cover with a soft dry cloth, then clean the inside of the printer. Carry out cleaning maintenance according to the operation manual if necessary.
Graph/text printer	Wipe away dust or stains on the printer cover with a soft dry cloth, then clean the inside of the printer. Carry out cleaning maintenance according to the operation manual if necessary.
Foot switch	Use a soft dry cloth with a little mild soapy water to wipe away dust or stains attached to the foot switch pedals or cable.
Barcode reader	Use a soft dry cloth to wipe away dust from the glass panel of the reader, then wipe away dust or stains from the cable and bracket. See Appendix D Barcode Reader for details.

17.1.2 Checking the Probe

- Visually check to confirm that there are no cracks or expansion of the probe head.
- Visually check to confirm that there is no deterioration or erosion of the probe cable.
- Visually check to confirm that none of the connector pins are bent, destroyed or falling off.

17.1.3 Checking the Power Cable and Plug

- Visually check to confirm that there are no wrinkles, cracks or deterioration, and no cracks or expansion on the surface of the adapter.
- Manually check to confirm that there is no looseness or rupture. The connection of the plug is reliable.

17.1.4 Checking the Circuit Breaker

Manually check to confirm that the circuit breaker can be turned on or off normally.

17.1.5 Checking Appearance

Check if there are any cracks in the covers:

- Ultrasound system covers
- Probe appearance.
- External appearance of the ECG lead.

17.1.6 System Hard Drive Backup

To prevent deterioration or loss of data stored in the system hard drive (including patient info data, preset data, etc.), create a backup copy of the hard drive at regular intervals.

17.2 Troubleshooting

If any persistent system malfunction is experienced, e.g., an onscreen error message, blank imaging screen, absent menus, see the table below. If the failure cannot be resolved, contact the Mindray Customer Service Department or a sales representative.

Troubleshooting Table

Failure	Cause	Measure
After the AC power input is connected, the power indicator does not light up.	Abnormal power system or incorrect connection of the power cord.	Check that the system is plugged in.
		Check that the plug has not become loose or dislodged from the back of the system.
The power indicator of the monitor is lit up, but the image is blank.	The interval between turning off and restarting the system is too short – wait at least 20 seconds.	Turn off the system and wait at least 1 minute, then restart the system.
	The monitor brightness or contrast may be improperly set.	Adjust the monitor brightness and contrast back to the factory defaults.
The monitor displays the characters and menus but no images.	The transmission power, overall gain or TGC controls are improperly set.	Adjust the transmission power, gain or TGC control.
	Check that a probe is connected and/or fully connected.	Ensure proper probe connection.
	The system is in freeze status.	Unfreeze the image.
The image quality is degraded	The exam mode is incorrect.	Select an appropriate exam mode.
	The image post-processing settings are incorrect.	Adjust the image post-processing settings or reset post-processing to the default values.
	The image presets are inappropriate.	Reset the factory default presets.
The button does not respond and the system is buzzing	There is dirt blocking the button	Check the control panel for the blocked button and press it several times to release it.
		Clean the button.

Appendix A Wireless LAN

The system provides wireless net adapter configuration, so as to assist information query and unlimited network service.

WARNING

It is prohibited to use the wireless LAN function in an airplane, as this may violate the relevant provisions in the aviation regulations.

Use the wireless LAN function prudently in emergency ambulances (or other vehicles) as other devices or communication signals may be interfered with.

Use the wireless LAN function prudently in OR/ICU/CCU as it may interfere with other devices.

When the wireless LAN function is turned on, the ultrasound system may suffer interference from other equipment, even if that other equipment complies with CISPR EMISSION requirements.

Keep at least 20 cm away from the ultrasound system when the wireless LAN function is in use.

NOTE: Disconnection may be caused if the devices connected exceed the router capacity (please refer to settings of the router, generally it should be ≤ 5 .)

DO NOT connect devices other than specified into the LAN.

Medical devices within the same LAN may interfere with each other, the operator should be cautious. (Do not connect devices that may cause strong interference. For example, life-supporting devices should not be connected in the same LAN.)

Other non-medical devices in the same frequency band may cause interference, please be cautious.

For a better wireless LAN transmission effect, please take the following settings:



- SSID > 80% with stable WLAN network;
- Wireless router and the server are in the same network segment;
- Router setting:
 - Wireless standard 802.11n
 - Maximum transmission speed $\geq 300\text{M}$
 - Use AP (access point) setting;
 - Number of the devices connected to the same router ≤ 5 .
- Target server setting:
 - Network is stable and not under overloading state (e.g. high CPU/memory usage, fast HDD speed, limited HDD space);
 - Level other than the highest level of firewall is adopted;
 - Operating system is Win8 or higher versions and it supports a Gigabit Ethernet

Wi-Fi function is not affected when the system is imposed with radiation interference complied with IEC60601-1-2:2007 standard.

A.1 Use the Wireless feature

1. Press <Cursor> to show the cursor, click  in the bottom bar to open the wireless network manager.
2. Roll the trackball and press <Set> to select the target network, click [Connect] to connect to the network.

When connecting an encrypted network, enter the password in the box first. You can select to hide password characters or not.

3. The system tries to connect and the wireless manager icon turns into . The icon turns into  or  after successful connection.



A.2 IP Config

Note: When the system background is processing network task (DICOM sending for example), please do not enter network setting to change the IP, otherwise the background task may fail. You can check if there are tasks undergoing in the task manager.

IP config is used for setting local network parameters, which is also applied to DICOM connection.

1. In Wireless network manager screen, click [IP Config] to open the page:



- If "DHCP" is selected, the IP address will be automatically obtained from the DNS server.
 - Click [Refresh] to check current IP address.
 - If "Static" is selected (using a static IP address), enter the IP address.
 - IP address of the system should be in the same network segment with the server.
 - Subnet Mask: set different network segment.
 - Gateway: set the gateway IP.
2. Click [Apply] to save current setting. Click [Close] to exit.

Note: If the IP address displays as 0.0.0.0, this means that the network is abnormal. The reason for the failure may be disconnection or the system cannot obtain the IP address.

A.3 Specifications

■ Wireless specification and technology:

No.	Item	Specifications
1	Standards	IEEE 802.11 a/b/g/n
2	Modulation mode	802.11b: DSSS 802.11a/g/n: OFDM
3	Operating frequency	2.412-2.472 GHz, 2.484 GHz
4	Channel spacing	5 MHz
5	Output power	≤17dbm
6	Wireless network mode	Infrastructure, ad-hoc

■ Wireless Quality of Service:

No.	Item	Specifications
1	Data rate	802.11b: up to 11 Mbps @ 2.4 GHz 802.11g: up to 54 Mbps @ 2.4 GHz 802.11n: up to 300 Mbps @ 2.4 GHz and 5 GHz
2	Data security	WPA2-PSK encryption
3	Application-layer delay	No requirement. It's not used in real time.
4	Application-layer reliability	No requirement. Application failure will be notified to the user immediately.
5	System capacity	No more than one device can be allowed to link to the ultrasound system
6	System anti-interference	Can be coexistent with other Wi-Fi devices.
7	Network interruption alarm	Network interruption is notified by disconnection icon and failure in transmission is notified by the dialog box.
8	EMC test process	Wi-Fi function is not affected when the system is imposed with radiation interference complied with IEC60601-1-2:2007 standard.

A.4 Troubleshooting

Failure	Measure
Unable to connect the network.	<ol style="list-style-type: none">1. Verify that network is available.2. The SSID and password of the device should be consistent with those of the wireless AP.3. Check for IP address conflict. If yes, set the IP address correctly.4. Check if Mindray recommended wireless AP is used. If not, verify the AP effective transmission rate meets the throughput requirements of the connected devices.
The ultrasonic device is frequently off line or disconnects from the network. The transmission delay is too long.	<ol style="list-style-type: none">1. Check if Mindray recommended wireless AP is used. If not, verify the AP effective transmission rate meets the throughput requirements of the connected devices.2. Verify that no unauthorized devices are connected to the wireless AP.

Appendix B Battery

 **WARNING:** The battery is inside the machine. Only Mindray technical professionals or engineers authorized by Mindray following training can perform battery installation and uninstallation.

If you need to change the battery or buy a new one, contact your sales representative.

B.1 Overview

When the system is working, the battery charges when its capacity is not full. The indicator turns off when the capacity is full.

- Under power off or standby status, charging time of the battery from capacity 0 to 100% takes less than 4 hours.



NOTE: Power off the system if it will not be used for a long period of time (including storage/transportation condition). Do not leave the system in standby status, otherwise the batteries will be discharged and permanently damaged.

B.2 Battery specification

Voltage	14.8V
Capacity	5800mAh (single battery)

B.3 Battery Status Indicator

The battery status indicator is located in the bottom-right corner of the screen, indicating the battery capacity.

- : Indicates the battery capacity is nearly empty.
- : Indicates the battery capacity is full.

Appendix C iWorks (Auto Workflow Protocol)

C.1 Overview

The main objective of ultrasound workflow automation (iWorks) is to speed up exam times and reduce the excessive number of user interface manual key strokes that can lead to repetitive strain injuries over time. It automates a clinical workflow in common exam protocols in a logical “step by step” manner. It also prevents missing important parts of examinations as well as decreasing exam times.

A Protocol Event contains series workflow events (annotation comments, body marks and measurements) and image modal commands to assist the user in routine ultrasound examinations.

The system provides different protocol events based on the different application regions.

iWorks is an option.

C.2 Normal iWorks Basic Procedure

1. Enter the patient information.
2. Press <Cursor> to show the cursor, click [iWorks] on the menu in the top-left corner of the screen to enter the protocol selection screen, and use the trackball and <Set> to select the corresponding protocol to enter the status.
3. After the system enters the iWorks screen, the available protocol is displayed on the screen. Perform the scanning and saving according to the screen prompt.
Perform measurements or add comments/body marks to the image according to the screen prompt.
4. After a view scanning is complete, press the user-defined save key to switch to the next view according to the screen prompt.
5. Repeat step 3 and step 4 to acquire all the necessary images.
 - If a pathology is discovered, click [Insert] to select a protocol outside of the normal routine to start scanning.
 - Click [Repeat] to add a copy of the selected view to work on if necessary.
 - Click [Next] or [Previous] to skip to a particular view you are interested in.
 - Click [Replace] to delete images and operations for the selected view and restart operations on that view.
 - Click [Delete] to delete the currently activated view.
 - Click [Suspend] to start a manual scan when an unusual or atypical workflow is required, and click [Resume iWorks] to restart the iWorks procedure.
6. After all views are finished, the system will prompt you to exit iWorks. Click [Yes] to exit. Or click [Stop] to exit iWorks in advance.

C.3 iWorks OB Procedure

iWorks OB is a variation on the “iWorks” feature. iWorks is based on protocol events occurring in a linear “step by step” succession. iWorks OB accommodates protocol events that occur in a “random” or non-linear manner.

1. Enter the patient information.
2. Press <Cursor> to show the cursor, click [iWorks] on the menu in the top-left corner of the screen to enter the protocol selection screen, and use the trackball and <Set> to select the corresponding protocol to enter the status.
3. After the system enters the iWorks screen, four categories of available views are displayed on the left part of the screen.
4. Use the trackball and <Set> key to select a view.
5. Scan and save according to the screen prompt.
6. Perform measurements or add comments/body marks to the image according to the screen prompt.
7. Repeat step 4 and step 5 to acquire all the necessary images.
 - If a pathology is discovered, click [Insert] to select a protocol outside of the normal routine to start scanning.
 - Click [Repeat] to add a copy of the selected view to work on if necessary.
 - Click [Next] or [Previous] to skip to a particular view you are interested in.
 - Click [Replace] to delete images and operations for the selected view and restart operations on that view.
 - Click [Delete] to delete the currently activated view.
 - Click [Suspend] to start a manual scan when an unusual or atypical workflow is required, and click [Resume iWorks] to restart the iWorks procedure.
8. After all views are finished, the system will prompt you to exit iWorks. Click [Yes] to exit. Or click [Stop] to exit iWorks in advance.

C.4 Screen Display

■ Normal iWorks

For automated protocols of vascular, small parts, cardiac, abdomen and gynecology application regions, the monitor displays the following screen:

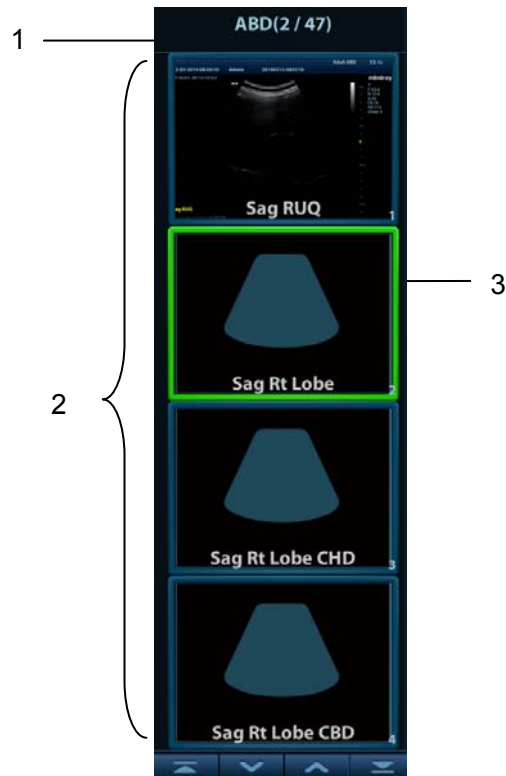

Name	Description
1	Displays the protocol name and the number of views contained. There may be prompt information here to indicate the following operation.
2	Displays the view steps in the protocol.
3	The current active view, with a solid green frame around the image.

■ iWorks OB



Name	Description
1	Displays the protocol name.
2	Completed view, with a green “√” on the left.
3	Current view type. The current active view, with a solid green frame around the image.
4	Contained views of the current type.
5	Saved views.

C.5 View Operation

In iWorks status, you can perform view selection, repeat, replacement and delete operations using the soft menu.

For some views, the system switches to the relevant imaging modes if necessary.

The comment for the current view has been automatically added to the bottom-left corner of the image, ready for you to scan the specified anatomy.

C.5.1 View Selection

Click [Previous]/[Next] to select the view to be scanned. The current view is surrounded by a solid green frame.

C.5.2 View Operation

In the current active view, you can perform image scanning, measurements, and adding comments and body marks, etc. Operations are the same as those for manual operation. See the relevant chapters for details.

C.5.3 Repeat View

If necessary, click [Repeat] to insert another template of the current view. You can then perform an extra examination.

C.5.4 View Replacement

The previous image will be deleted and replaced by the new image.

C.5.5 Delete View

Click [Previous]/[Next] to select the view to be deleted. Click [Delete] to delete the selected view.

C.6 Check Undone Section

You can quickly check and select an undone view using [Undone] on the soft menu.

Click [Undone] on the screen to enter the selecting dialog box on the soft menu and select the desired view to enter the status.

C.7 Manual Examination

Suspend - Exit the protocol so the user can run the system manually. This is used when an unusual or atypical workflow is required.

You can run the system manually if necessary.

- Start manual examination: click [Suspend] to pause the current iWorks protocol. The system enters manual examination status.
- Return to iWorks: click [Resume iWorks] on the menu in the top-left corner of the screen to return to automated status. You can continue the previous iWorks scan.

C.8 Insert

Insert is a specialized protocol event within iWorks and iWorks OB. It assists with the workflow for documenting and measuring common pathological (disease) states (i.e. Mass, Cyst, Stenosis, Thrombus) that occurs outside a routine, normal examination.

1. Click [Insert] on the soft menu to enter the status.
2. Select the necessary protocol and the system adds the protocol events to the current protocol.
3. Perform measurements or add comments/body marks to the image if necessary.

C.9 iWorks Setting

Enter the iWorks preset screen using the path: “[Setup] → [iWorks Preset].” Here you can customize the protocols and views:

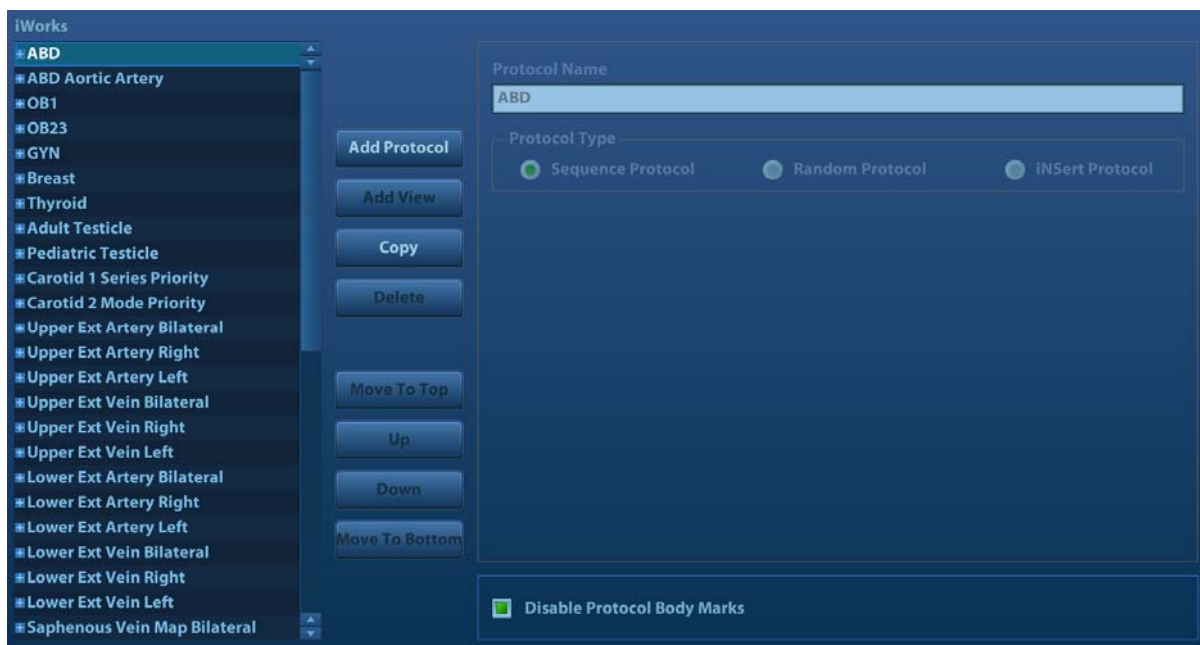

C.9.1 Protocol Management

- Click to select the protocol in the list. The protocol type can be checked on the right.
- Click [Add Protocol] to create a new protocol. It can be customized.
- Click to select a protocol in the list on the left and click [Copy]. A protocol named “copy of XXX” is created with the copied views, which can be customized.
- Click [Delete] to delete a user-defined protocol.
- Click [Up] or [Down] to move the selected protocol.
- Click [Move to Top]/[Move to Bottom] to move the selected protocol to the top or bottom of the list.

C.9.2 View Management

- Click to select the views in the list. The image, annotation, body mark and measurement settings can be checked on the right.
- Click to select a user-defined protocol in the list. Click [Add View] to add a view template to the protocol.

C.9.3 Create New Protocol

You can create user-defined protocols and customize the automated procedure.

1. In the iWorks preset screen, click [Add Protocol] to create a new protocol. Enter the protocol name, type and select the application region.

Or, select an existing protocol and click [Copy] to customize the protocol based on the previous template.

2. Click [Add View] to enter the view name and perform image settings as shown in the following figure.



3. Add comments, body marks and perform measurement settings, as shown in the following figure:

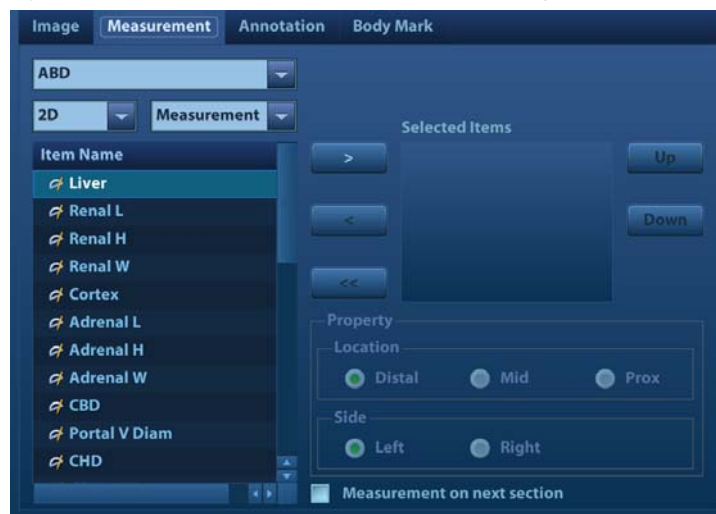

In the image setting, if “Measurement on next section” is selected, the system will save two section images after finishing the section operation. One of the two sections will include the measurement result.

4. Select the checkbox for body mark display setting.
5. Click [Save] to complete the setting and exit.

Appendix D Barcode Reader

The product supports two kinds of readers for logging data as patient ID: 1-D barcode reader (SYMBOL LS2208) and 2-D barcode reader (SYMBOL DS6707). The laser transmitted by the two readers is Class 2 laser.

⚠ WARNING: A Class 2 laser uses a low-power, visible LED. DO NOT stare into the beam due to unknown hazards of transient radiation from Class 2 lasers.

⚠ CAUTION: Ensure the information acquired by the barcode reader is consistent with the actual information.

There are 2 operation modes:

Hand-held mode: press the trigger to decode.

Hands-free mode: position the reader in the stand to enter the mode. The reader decodes automatically.

NOTE: The reader does not support Multilanguage decoding.

D.1 1D Barcode Reader

D.1.1 Overview



1.	LED	Green: a barcode was successfully decoded. Red: a data transmission error or reader malfunction occurred.
2.	Scan window	Scan the barcode.
3.	Trigger	Press to decode

D.1.2 Setting Up the Reader (taking LS2208 as an example)

1. Plug the interface cable modular connector into the cable interface port on the bottom of the reader handle and ensure the connector is properly secured.
2. Connect the other end of the interface cable to the host.

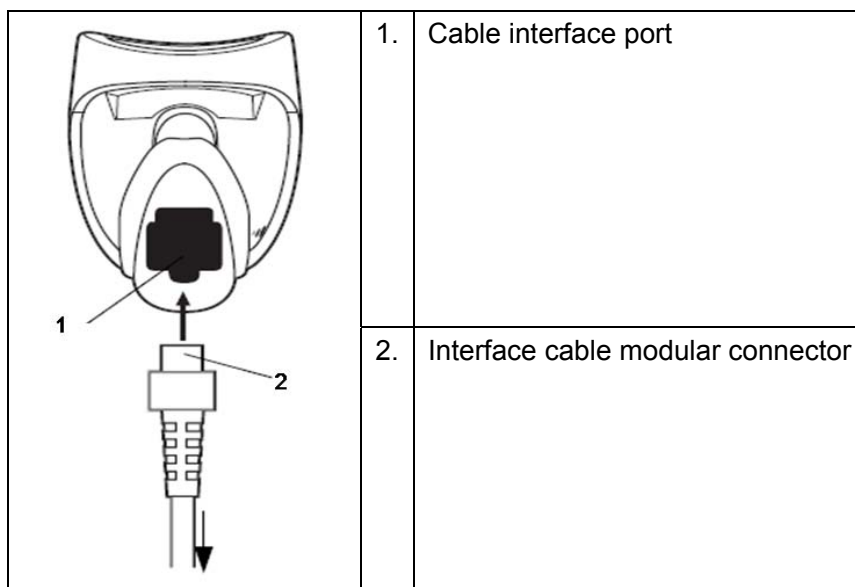

D.1.3 Setting

The reader has factory settings. See A.4 for details.

The reader supports some user-defined functions as described below.

For more details, contact the SYMBOL reader agent or the Mindray Customer Service Department.

■ Volume setting:

Scan the following barcode to set the volume parameter.



Low Volume



Medium Volume



High Volume

■ Code 93 and codebar scanning:

To enable or disable Code 93, scan the appropriate barcode below.



Enable Code 93

To enable Codebar, scan the appropriate barcode below.



Enable Codabar

■ Code 39 Full ASCII scanning:

Code 39 Full ASCII is a variant of Code 39 which pairs characters to encode the full ASCII character set. To enable or disable Code 39 Full ASCII, scan the appropriate barcode below.



Enable Code 39 Full ASCII









Disable Code 39 Full ASCII

■ I 2 of 5 symbols setting:



I 2 of 5 - One Discrete Length

Select this option to decode only I 2 of 5 symbols containing a selected length. Select the length using the numeric barcodes below. For example, to decode only I 2 of 5 symbols with 8 characters, scan **I 2 of 5 - One Discrete Length**, then scan **0** followed by **8**.

 0	 1
 2	 3
 4	 5

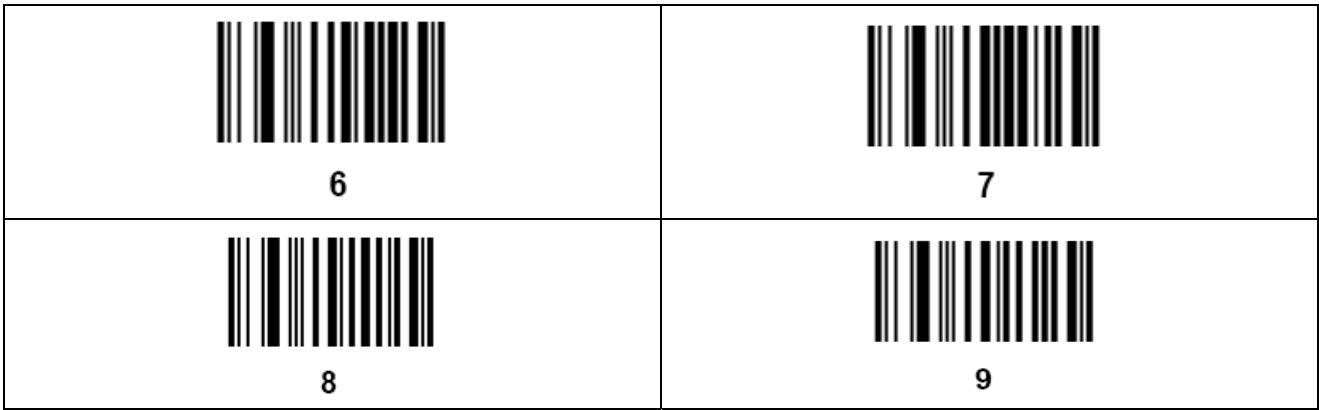

D.1.4 Scanning in Hand-Held Mode

1. Ensure all connections are secure.
2. Aim the reader at the barcode. Press the trigger.

NOTE: Ensure the scan line crosses every bar and space of the symbol, see the figure below.

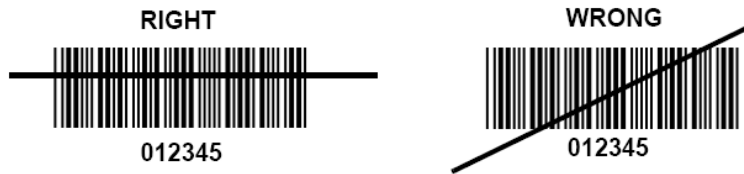

3. If decoding is successful, the reader beeps and the LED turns green.

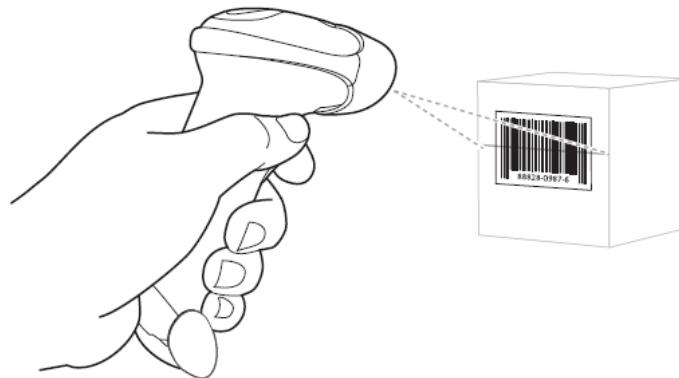

Tip: Do not hold the reader directly over the barcode. Laser light reflecting *directly* back into the reader from the barcode is known as specular reflection. Specular reflection can make decoding difficult. You can tilt the reader up to 55° forward or backward and achieve a successful decoding

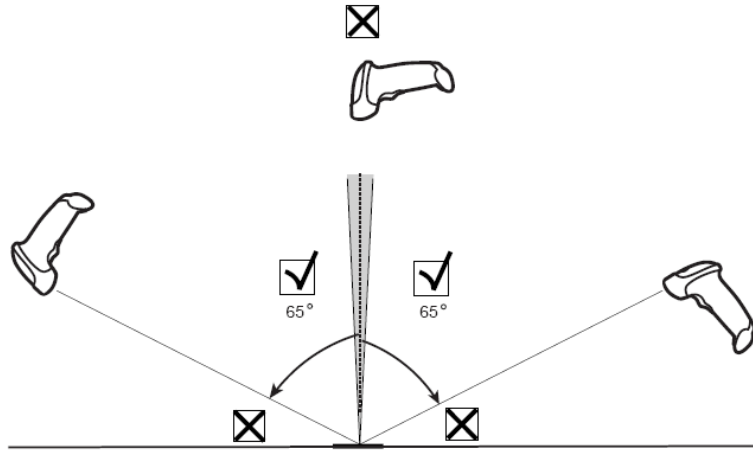

D.1.5 Scanning in Hands-Free Mode

Assembling the Intellistand

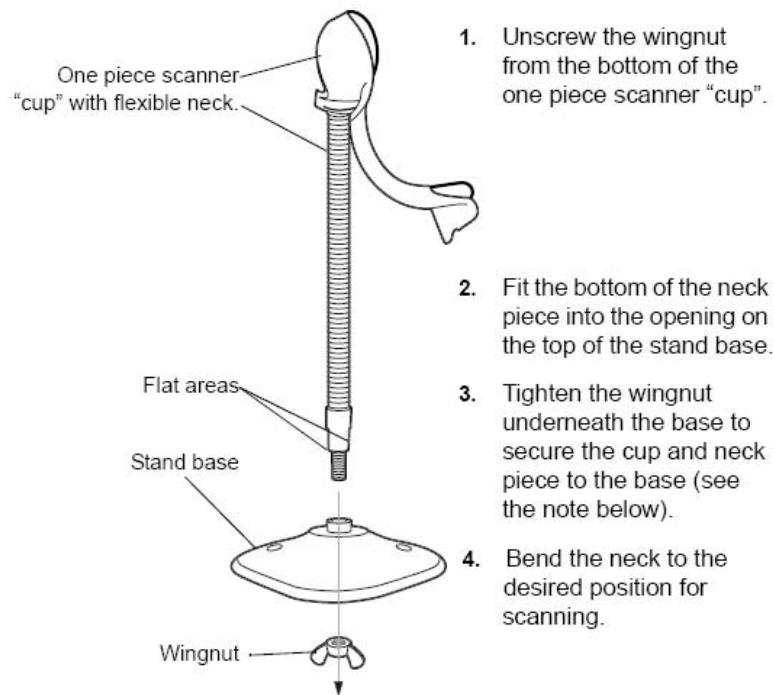

NOTE: Before tightening the wingnut under the base, ensure that the flat areas on the flexible neck fit securely in the grooves in the base.

Mounting the Stand (optional)

You can attach the base of the reader's stand to a flat surface using two screws or double-sided tape (not provided).

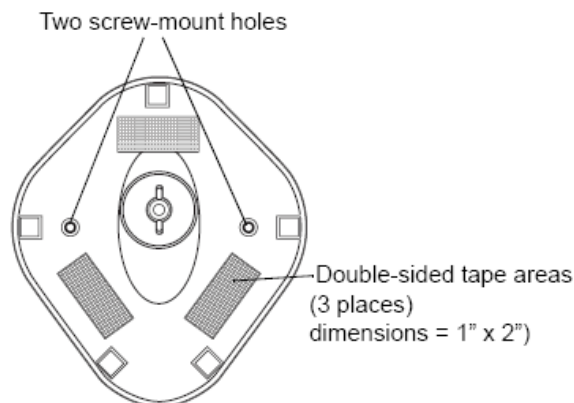

■ Screw Mount

1. Position the assembled base on a flat surface.
2. Screw one #10 wood screw into each screw-mount hole until the base of the stand is secure

■ Tape Mount

1. Peel the paper liner off one side of each piece of tape and place the sticky surface over each of the three rectangular tape holders.

2. Peel the paper liner off the exposed sides of each piece of tape and press the stand on a flat surface until it is secure.

Scanning in Hands-Free Mode

When the reader is seated in the stand's "cup", the reader's built-in sensor puts the reader into hands-free mode. When the reader is removed from the stand it operates in its normal hand-held mode.

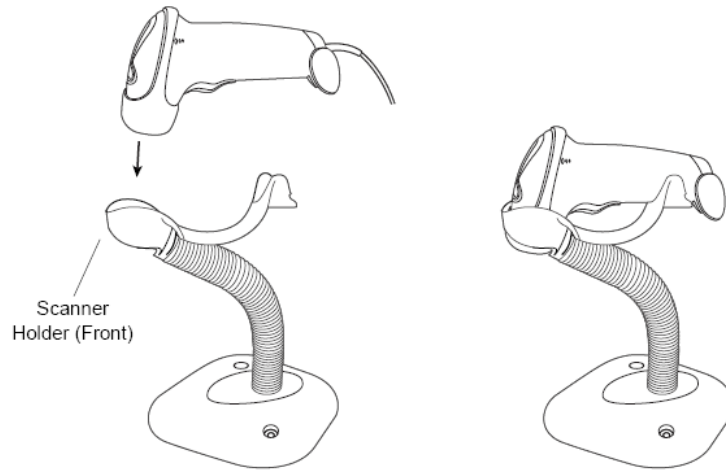

D.2 2-D Barcode Reader (Take DS6707 as an example)

D.2.1 Overview

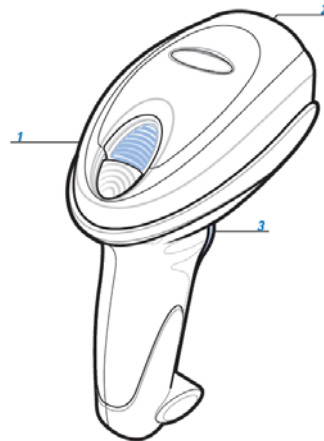

1.	LED	Green: A barcode was successfully decoded. Red: A data transmission error or reader malfunction occurred.
2.	Scan window	Scan the barcode.
3.	Trigger	Press to decode

D.2.2 Setting Up the Digital Imager Reader

D.2.2.1 Installing the Interface Cable

1. Plug the interface cable modular connector into the cable interface port on the bottom of the reader handle and ensure the connector is properly secure.
2. Connect the other end of the interface cable to the host

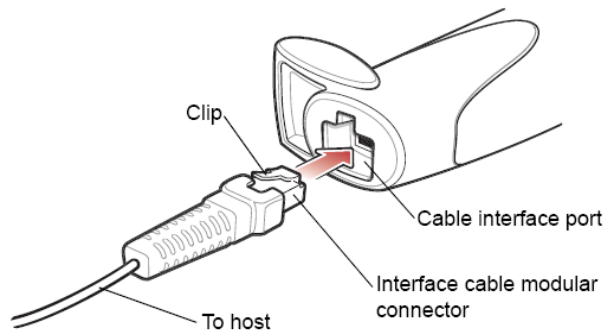

D.2.2.2 Removing the Interface Cable

1. Using the tip of a screwdriver or some other tools with a sharp head, depress the cable's modular connector clip.

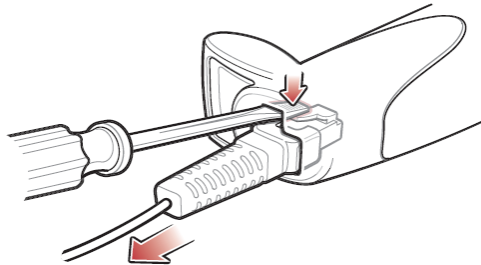

2. Carefully slide out the cable.

D.2.3 Setting

The reader has factory settings; please refer to A.4 for details.

The reader supports some user-defined functions as introduced below.

For more details, please contact the SYMBOL reader agents or Mindray Customer Service Department.

■ Volume setting:

Scan the following barcode to set the volume parameter.



Low Volume
(02h)



Medium Volume
(01h)



**High Volume
(00h)**

■ code 93 and codebar setting

To enable Code 93, scan the appropriate barcode below.



**Enable Code 93
(01h)**

To enable Codebar, scan the appropriate barcode below.



**Enable Codabar
(01h)**

■ code 39 full ASCII setting

Code 39 Full ASCII is a variant of Code 39 which pairs characters to encode the full ASCII character set. To enable or disable Code 39 Full ASCII, scan the appropriate barcode below.

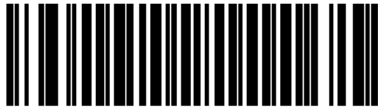

**Enable Code 39 Full ASCII
(01h)**







**Disable Code 39 Full ASCII
(00h)**







■ I 2 of 5 symbols setting



I 2 of 5 - One Discrete Length

Select this option to decode only I 2 of 5 symbols containing a selected length. Select the length using the numeric barcodes below. For example, to decode only I 2 of 5 symbols with 8 characters, scan **I 2 of 5 - One Discrete Length**, then scan **0** followed by **8**.

 0	 1
 2	 3

 4	 5
 6	 7
 8	 9

D.2.4 Scanning in Hand-Held Mode

1. Ensure all connections are secure (see the appropriate host chapter.)
2. Aim the digital imager reader at the barcode.

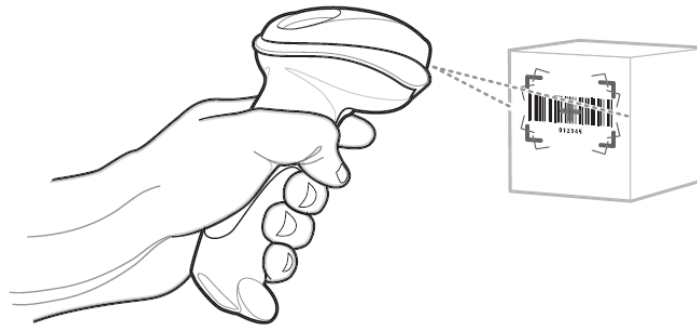

3. When the digital imager reader senses movement, in its default **Auto Aim** trigger mode, it projects a red laser aiming pattern which allows positioning the barcode or object within the field of view.

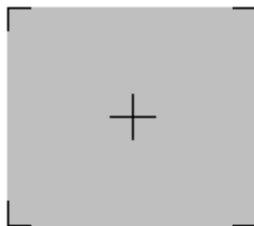

If necessary, the digital imager reader turns on its red LEDs to illuminate the target barcode.

4. Center the symbol in any orientation within the aiming pattern. Be sure the entire symbol is within the rectangular area formed by the brackets in the pattern.

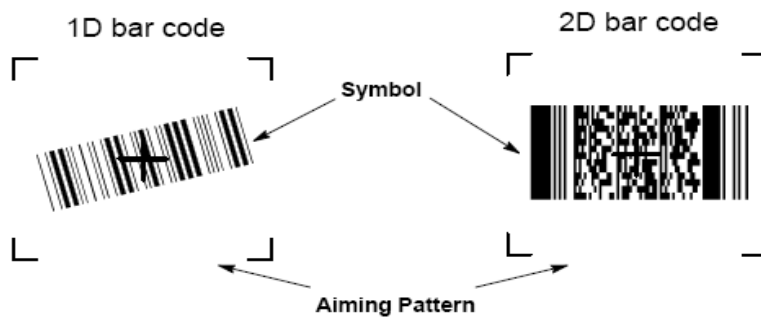

5. Hold the trigger until the digital imager reader beeps, indicating the barcode is successfully decoded.

Note: Steps 2 - 4 may be required to repeat on poor quality or difficult barcodes.

Tips: Hold the digital imager reader between two and nine inches (depending on symbol density) from the symbol, centering the aiming pattern cross hairs on the symbol.

The aiming pattern is smaller when the digital imager reader is closer to the symbol and larger when it is farther from the symbol. Scan symbols with smaller bars or elements (mil size) closer to the digital imager reader, and those with larger bars or elements (mil size) farther from the digital imager reader.

The digital imager reader can also read a barcode presented within the aiming pattern but not centered. The top examples in show acceptable aiming options, while the bottom examples cannot be decoded.

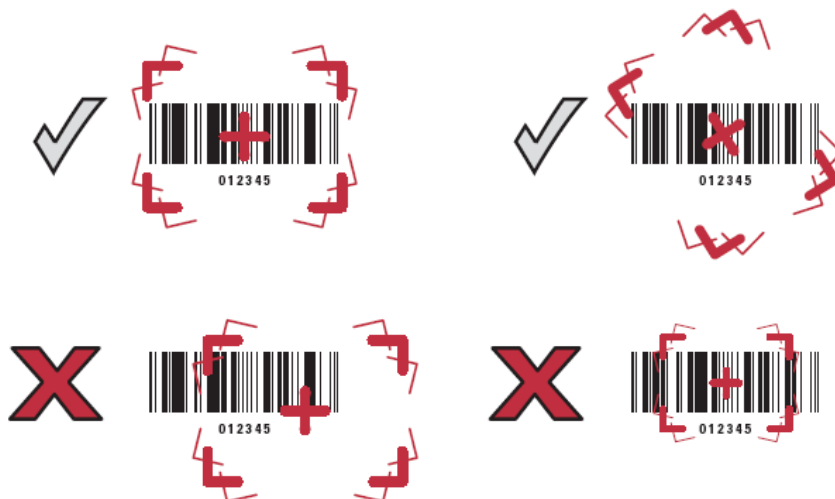

D.2.5 Scanning in Hands-Free Mode

The optional Intellistand adds greater flexibility to scanning operation. When the digital imager reader is seated in the stand's "cup," the digital imager reader's built-in sensor places the digital imager reader in hands-free mode. When the digital imager reader is removed from the stand it operates in its normal hand-held mode.

Use the Intellistand's adjustment knobs to adjust the height and angle of the digital imager reader.

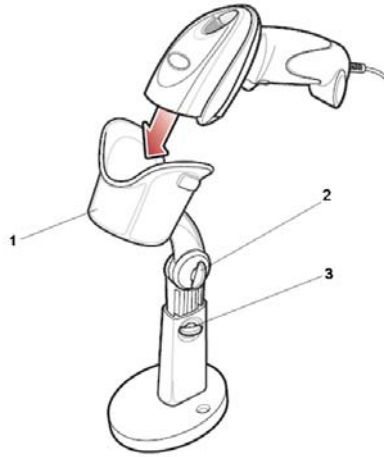

1.	Reader holder (cup)
2.	Angle adjustment knob
3.	Height adjustment knob

D.3 Setting in Ultrasound System

Press <Setup> to enter the Setup menu and select [Scan Code] to see the following screen.

The screenshot shows the 'Scan Code' configuration screen. At the top, there are navigation tabs: Region, General, Image, Application, OB, Key Config, Admin, and Scan Code (which is active). Below the tabs, there are several configuration options:

- Bar Code Reader:** A dropdown menu currently set to '1D'.
- Input Patient Data mode:** Two radio buttons: 'Only Patient ID' (selected) and 'Combination Item'.
- Barcode Data:** A text input field.
- Start and End positions:** A table with columns 'Start' and 'End' for various parameters: Patient ID, Other ID, First name, Last name, Middle name, Age, Birth(Year), Birth(Month), Birth(Day), and Gender.
- Unit:** A dropdown menu set to 'Years'.
- Gender:** Two checkboxes labeled 'Male' and 'Female'.

At the bottom, a note reads: "Note: If the barcode does not contain the information of any item, configure the Start and End position as '0'".

Setting items are described as follows:

Parameter	Description
Bar Code Reader	Select type: 1D or 2D.
Input Patient Data mode	Select the mode for inputting patient data. Only Patient ID: only patient ID is acquired from barcode reader. If this function is selected, patient ID can be acquired via barcode reading in Patient, Worklist or QR screen. Combination Item: patient ID, patient name and other information can be acquired from barcode.(available only in 2-D reader)
Barcode Data	When 2-D reader is adopted, you should first scan a sample barcode here and then set the parts definition for the information.
Patient ID Patient Name Age Birth Gender	Set the start and end position of each item. Note: 1. Length of birth month and data are of 2 letters. 2. If one item of information is not included in the barcode, set the start and end position of the item to be 0 respectively.

D.4 Parameter Defaults

Refer to the following table for parameter defaults of LS2208 and DS6707.

Parameter	Defaults
1-D Symbolologies	
UPC/EAN	
UPC-A	Enable
UPC-E	Enable
UPC-E1	Disable
EAN-8/JAN 8	Enable
EAN-13/JAN 13	Enable
Bookland EAN	Disable
Decode UPC/EAN/JAN Supplementals (2and 5 digits)	Ignore
UPC/EAN/JAN Supplemental Redundancy	10
Transmit UPC-A Check Digit	Enable
Transmit UPC-E Check Digit	Enable
Transmit UPC-E1 Check Digit	Enable
UPC-A Preamble	System Character
UPC-E Preamble	System Character
UPC-E1 Preamble	System Character
Convert UPC-E to A	Disable
Convert UPC-E1 to A	Disable
EAN-8/JAN-8 Extend	Disable
UCC Coupon Extended Code	Disable
Code 128	
Code 128	Enable
UCC/EAN-128	Enable
ISBT 128	Enable
Code 39	
Code 39	Enable
Trioptic Code 39	Disable
Convert Code 39 to Code 32 (Italian Pharmacy Code)	Disable
Code 32 Prefix	Disable
Set Length(s) for Code 39	2 to 55
Code 39 Check Digit Verification	Disable
Transmit Code 39 Check Digit	Disable
Code 39 Full ASCII Conversion	Disable
Buffer Code 39	Disable
Code 93	
Code 93	Enable
Set Length(s) for Code 93	4 to 55
Interleaved 2 of 5 (ITF)	
Interleaved 2 of 5 (ITF) Enable	Enable
Set Lengths for I 2 of 5	14
I 2 of 5 Check Digit Verification	Disable
Transmit I 2 of 5 Check Digit	Disable
Convert I 2 of 5 to EAN 13	Disable
Codabar (NW - 7)	
Codabar	Enable
Set Lengths for Codabar	5 to 55
CLSI Editing	Disable
NOTIS Editing	Disable
2-D Symbolologies	
PDF417	Enable
MicroPDF417	Disable
Code 128 Emulation	Disable
Data Matrix	Enable
Maxicode	Enable

Parameter	Defaults
QR Code	Enable

D.5 Maintenance

Cleaning the exit window is the only maintenance required. A dirty window can affect scanning accuracy.

- Do not allow any abrasive material to touch the window.
- Remove any dirt particles with a damp cloth.
- Wipe the window using a tissue moistened with ammonia/water.
- Do not spray water or other cleaning liquids directly into the window.

Appendix E Trolley



WARNING:

Be sure to connect the equipotential wire before inserting the power plug into the receptacle; be sure to remove the power plug from the receptacle before disconnecting the equipotential wire; otherwise electric shock may result.

When you connect another device to the trolley, you should use the equipotential wire to connect each of equipotential terminals; otherwise electric shock may result.

Connect the earth cable before powering ON. Disconnect the earth cable after powering OFF. Otherwise, electric shock may result.

DO NOT connect the trolley to the outlets with the same circuit breakers and fuses that control the current to devices such as life-support systems. If the trolley or the system malfunctions and generates over-current, or when there is an instantaneous current at power ON, the circuit breakers and fuses of the building's supply circuit may be tripped.

If UMT-300 has configured with display module, please take care of the display module position to leave enough space below when adjusting the display support arm, so that the display module will not hit into the monitor of the ultrasound system.



CAUTION:

When moving the trolley with mounted system, please take care of the connector of the power adapter in case of damage.

Maximum output power of the outlet in the trolley is 240VA.

E.1 Configuration

E.1.1 Standard configuration

- UMT-500 accessories:
 - Probe& gel holder
 - Probe cable hook
 - Storage tray
 - Black / white video printer bracket
 - Storage basket
- UMT-500Plus accessories:
 - Power cord
 - Cover grounding cable
 - Probe& gel holder
 - Probe cable hook
 - Storage tray
 - Black / white video printer bracket
 - Storage basket
 - Auxiliary output cable

E.2 Power supply

Voltage	100-240V~
Frequency	50/60Hz
Input power	500VA
Fuse	250V~T5AL, 250V~T5AH

Battery voltage	14.8V
Capacity	6600mAh (single battery)

E.3 Introduction of Each Unit (taking UMT-500Plus as an example)

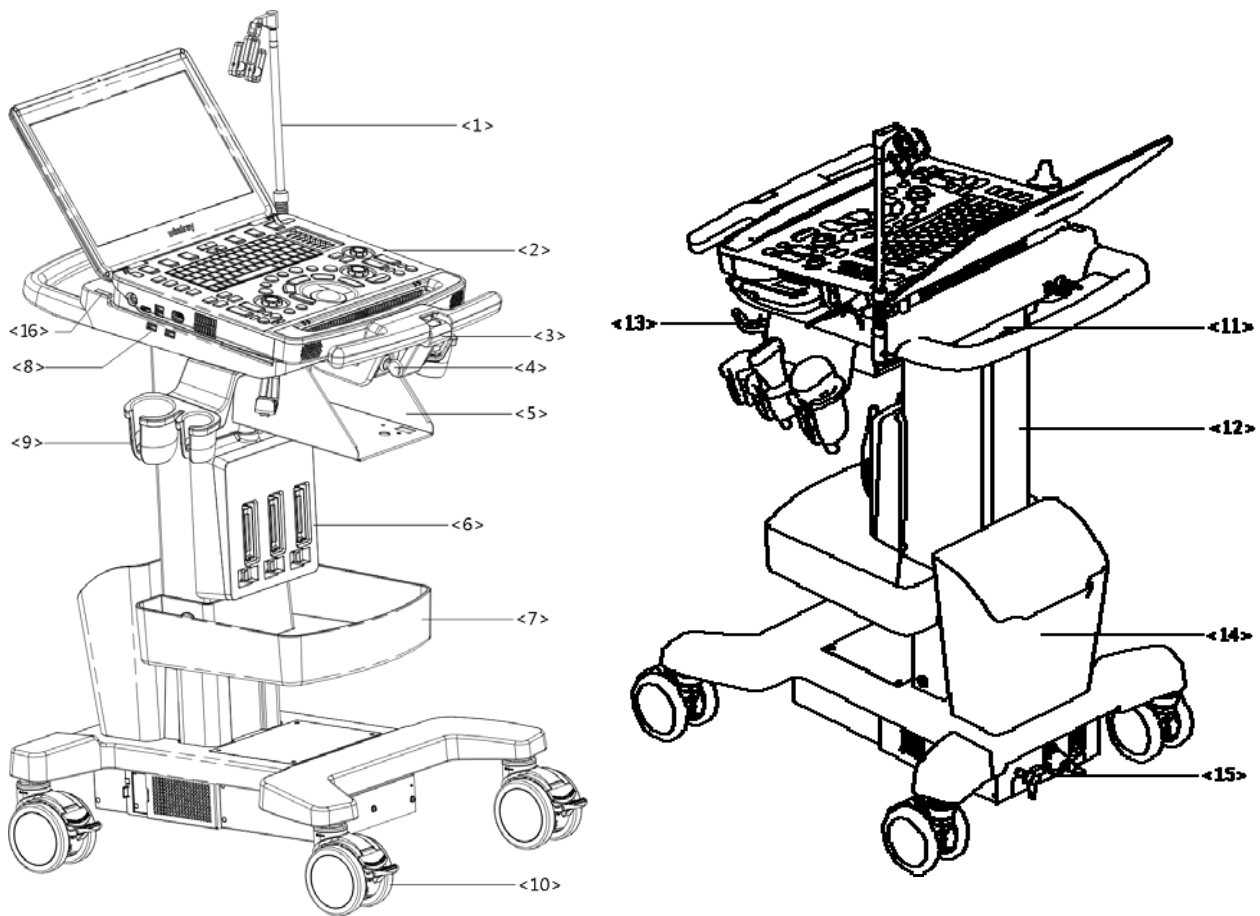

No.	Name	Function
<1>	Probe cable hook	Manage probe cable
<2>	Ultrasound main unit	Ultrasound system
<3>	Ascending/descending switch	Press to adjust the height of operation panel
<4>	Anti-theft lock	Used for fix the ultrasound system to the trolley.
<5>	Printer bracket	Used for place the printer
<6>	Probe extension module	Used for extend ports for connecting probes (optional)
<7>	Storage tray	Used for place the adaptor, gel and other stuff.
<8>	USB port 	Connects USB devices (2 ports)
<9>	Probe holder	Used for place probes temporarily
<10>	Caster	Used for securing or moving the system Step on the second footswitch to lock the trolley. Step on the first footswitch to unlock the trolley.
<11>	Audio/video extender	Used for switch audio/video (optional)
<12>	Lifting column	Used for adjust the height of operation panel
<13>	Moveable hook	Manage probe cable

No.	Name	Function
<14>	Storage box	Used for place report or other stuff.
<15>	Power supply panel	Used for offer output/input port, equipotential terminal for power supply.
<16>	Indicator	 Battery status indicator. Charging status: <ul style="list-style-type: none"> ● It illuminates in orange when batteries are charging; ● It illuminates in green when batteries are charged fully. ● It illuminates in green color when the power of the batteries is sufficient; ● It illuminates in orange color for low battery power. ~AC indicator <ul style="list-style-type: none"> ● The indicator is green at AC supply. ● The indicator is off when batteries are supplied without AC supply.

■ Power Supply Panel

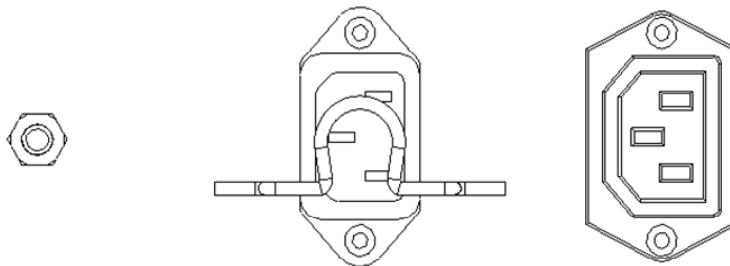

No.	Name	Function
1	Equipotential terminal	Used for equipotential connection, balancing the protective earth potentials between the system and other electrical equipment.
2	Power inlet	AC power inlet
3	Power outlet	Supply power for optional peripheral devices (e.g. DVR)

The symbol  represents the equipotential terminal that is used for balancing the protective earth potentials between the system and other electrical equipment.

⚠ WARNING: Be sure to connect the equipotential wire before inserting the power plug into the receptacle. Be sure to remove the power plug from the receptacle before disconnecting the equipotential wire. Failure to do so may result in electric shock.

When you connect another device to this system, you should use the equipotential wire to connect each of equipotential terminals. Failure to do so may result in electric shock.

Connect the earth cable before turning the system ON. Disconnect the earth cable after turning the system OFF. Failure to do so may result in electric shock.

DO NOT connect this system to outlets with the same circuit breakers and fuses that control the current to devices such as life-support systems. If this system malfunctions and generates overcurrent, or when there is an instantaneous current at power ON, the circuit breakers and fuses of the building's supply circuit may be tripped.

E.4 Battery Overview

⚠WARNING: Only technical professionals from Mindray or engineers authorized by Mindray after training can perform battery installation and uninstallation. If you need to change the battery or buy a new one, please contact your sales representative.

External batteries performance on UMT-500Plus:

- Powering time of the battery is more than 90 minutes (condition: connect a convex probe by probe extend module under power on status with no peripherals. And scanning time takes 60% of the working time)

Under power off or standby status, charging time of the battery from capacity 0 to 100% takes less than 4.5 hours.

Appendix F Electrical Safety Inspection

The following electrical safety tests are recommended as part of a comprehensive preventive maintenance program. They are a proven means of detecting abnormalities that, if undetected, could prove dangerous to either the patient or the operator. Additional tests may be required according to local regulations.

All tests can be performed using commercially-available safety analyzer test equipment. These procedures assume the use of a 601PROXL International Safety Analyzer or equivalent safety analyzer. Other popular testers which comply with IEC 60601-1 and are used in Europe, such as Fluke, Metron or Gerb, may require modifications to the procedure. Follow the analyzer manufacturer's instructions.

An electrical safety inspection should be periodically performed every two years. The safety analyzer is also an excellent troubleshooting tool for detecting abnormalities in line voltage and grounding, as well as total current loads.

F.1 Power Cord Plug

F.1.1 The Power Plug

Test Item		Acceptance Criteria
The power plug	The power plug pins	No broken or bent pins. No discolored pins.
	The plug body	No physical damage to the plug body.
	The strain relief	No physical damage to the strain relief. No plug warmth when device is in use.
	The power plug	No loose connections.
The power cord		No physical damage to the cord. No deterioration to the cord.
		For devices with detachable power cords, inspect the connection with the device.
		For devices with non-detachable power cords, inspect the strain relief at the device.

F.2 Device Enclosure and Accessories

F.2.1 Visual Inspection

Test Item	Acceptance Criteria
The enclosure and accessories	No physical damage to the enclosure and accessories.
	No physical damage to meters, switches, connectors, etc.
	No residue of fluid spillage (e.g., water, coffee, chemicals, etc.).
	No loose or missing parts (e.g., knobs, dials, terminals, etc.).

F.2.2 Contextual Inspection

Test Item	Acceptance Criteria
The enclosure and accessories	No unusual noises (e.g., rattles inside the case).
	No unusual smells (e.g., burning or smoky smells, particularly from ventilation holes).
	No taped notes that may suggest device deficiencies or operator concerns.

F.3 Device Labeling

Check that the labels provided by the manufacturer or the healthcare facility are present and legible.

- Main unit label
- Integrated warning labels

F.4 Protective Earth Resistance

- Plug the analyzer probes into the device's protective earth terminal and the protective earth terminal of the AC power cord.
- Test the earth resistance with a current of 25 A.
- Verify the resistance is less than the limits.

■ LIMITS

ALL COUNTRIES R = 0.2 Ω Maximum

F.5 Earth Leakage Test

Run an Earth Leakage test on the device being tested before performing any other leakage tests.

The following outlet conditions apply when performing the Earth Leakage test.

- normal polarity (Normal Condition);
- reverse polarity (Normal Condition);
- normal polarity with open neutral (Single Fault Condition);
- reverse polarity with open neutral (Single Fault Condition).

■ LIMITS

For UL60601-1:

- 300 μ A in Normal Condition.
- 1000 μ A in Single Fault Condition.

For IEC60601-1:

- 500 μ A in Normal Condition.
- 1000 μ A in Single Fault Condition.

F.6 Enclosure Leakage Test

The following outlet conditions apply when performing the Enclosure Leakage test.

- normal polarity (Normal Condition);
- reverse polarity (Normal Condition);
- normal polarity with open neutral (Single Fault Condition);
- reverse polarity with open neutral (Single Fault Condition);
- normal polarity with open earth (Single Fault Condition);
- reverse polarity with open earth (Single Fault Condition).

■ LIMITS

For UL60601-1:

- 100 μ A in Normal Condition.
- 300 μ A in Single Fault Condition.

For IEC60601-1:

- 100 μ A in Normal Condition.
- 500 μ A in Single Fault Condition.

F.7 Patient Leakage Current

Patient leakage currents are measured between a selected applied part and mains earth. All measurements have a true RMS only.

The following outlet conditions apply when performing the Patient Leakage Current test.

- normal polarity (Normal Condition);
- reverse polarity (Normal Condition);
- normal polarity with open neutral (Single Fault Condition);
- reverse polarity with open neutral (Single Fault Condition);
- normal polarity with open earth (Single Fault Condition);
- reverse polarity with open earth (Single Fault Condition).

■ LIMITS

For BF  applied parts:

- 100 μ A in Normal Condition.
- 500 μ A in Single Fault Condition.

F.8 Mains on Applied Part Leakage

The Mains on Applied Part test applies a test voltage, which is 110% of the mains voltage using a limiting resistance, to selected applied part terminals. Current measurements are then taken between the selected applied part and earth. Measurements are taken with the test voltage (110% of mains) on applied parts in the normal and reverse polarity conditions.

The following outlet conditions apply when performing the Mains on Applied Part test.

- Normal Polarity;
- Reversed Polarity.

■ LIMITS

- For BF  applied parts: 5000 μ A.

F.9 Patient Auxiliary Current

Patient Auxiliary currents are measured between any selected Applied Part connector and the remaining Applied Part connectors. All measurements may have a true RMS response.

The following outlet conditions apply when performing the Patient Auxiliary Current test.

- normal polarity (Normal Condition);
- reverse polarity (Normal Condition);
- normal polarity with open neutral (Single Fault Condition);
- reverse polarity with open neutral (Single Fault Condition);
- normal polarity with open earth (Single Fault Condition);
- reverse polarity with open earth (Single Fault Condition).

■ LIMITS

For BF  applied parts,

- 100 μ A in Normal Condition.
- 500 μ A in Single Fault Condition.

NOTE: Make sure the safety analyzer is authorized and complies with the requirements of IEC61010-1. Follow the analyzer manufacturer's instructions.

